

# Embedded Coder<sup>®</sup> Release Notes



# MATLAB<sup>®</sup>&SIMULINK<sup>®</sup>

## How to Contact MathWorks



Latest news: [www.mathworks.com](http://www.mathworks.com)  
Sales and services: [www.mathworks.com/sales\\_and\\_services](http://www.mathworks.com/sales_and_services)  
User community: [www.mathworks.com/matlabcentral](http://www.mathworks.com/matlabcentral)  
Technical support: [www.mathworks.com/support/contact\\_us](http://www.mathworks.com/support/contact_us)



Phone: 508-647-7000



The MathWorks, Inc.  
3 Apple Hill Drive  
Natick, MA 01760-2098

### *Embedded Coder<sup>®</sup> Release Notes*

© COPYRIGHT 2011–2017 by The MathWorks, Inc.

The software described in this document is furnished under a license agreement. The software may be used or copied only under the terms of the license agreement. No part of this manual may be photocopied or reproduced in any form without prior written consent from The MathWorks, Inc.

**FEDERAL ACQUISITION:** This provision applies to all acquisitions of the Program and Documentation by, for, or through the federal government of the United States. By accepting delivery of the Program or Documentation, the government hereby agrees that this software or documentation qualifies as commercial computer software or commercial computer software documentation as such terms are used or defined in FAR 12.212, DFARS Part 227.72, and DFARS 252.227-7014. Accordingly, the terms and conditions of this Agreement and only those rights specified in this Agreement, shall pertain to and govern the use, modification, reproduction, release, performance, display, and disclosure of the Program and Documentation by the federal government (or other entity acquiring for or through the federal government) and shall supersede any conflicting contractual terms or conditions. If this License fails to meet the government's needs or is inconsistent in any respect with federal procurement law, the government agrees to return the Program and Documentation, unused, to The MathWorks, Inc.

### **Trademarks**

MATLAB and Simulink are registered trademarks of The MathWorks, Inc. See [www.mathworks.com/trademarks](http://www.mathworks.com/trademarks) for a list of additional trademarks. Other product or brand names may be trademarks or registered trademarks of their respective holders.

### **Patents**

MathWorks products are protected by one or more U.S. patents. Please see [www.mathworks.com/patents](http://www.mathworks.com/patents) for more information.

## Check Bug Reports for Issues and Fixes

Software is inherently complex and is not free of errors. The output of a code generator might contain bugs, some of which are not detected by a compiler. MathWorks reports critical known bugs brought to its attention on its Bug Report system at [www.mathworks.com/support/bugreports/](http://www.mathworks.com/support/bugreports/). Use the Saved Searches and Watched Bugs tool with the search phrase "Incorrect Code Generation" to obtain a report of known bugs that produce code that might compile and execute, but still produce wrong answers.

The bug reports are an integral part of the documentation for each release. Examine periodically all bug reports for a release, as such reports may identify inconsistencies between the actual behavior of a release you are using and the behavior described in this documentation.

In addition to reviewing bug reports, you should implement a verification and validation strategy to identify potential bugs in your design, code, and tools.



<b>Code Generation from MATLAB Code</b> .....	<b>1-2</b>
SIL and PIL execution improvements for MATLAB Coder . . .	1-2
Verification of PIL target connectivity configuration .....	1-2
Code Replacement for MATLAB Coder: Create code replacement library entries for target implementations that require data alignment .....	1-3
<b>Model Architecture and Design</b> .....	<b>1-4</b>
AUTOSAR arxml File Import: Flexibly model imported periodic, asynchronous, and initialization runnables .....	1-4
AUTOSAR DESC elements populate Simulink Description fields .....	1-5
External mode code generation for a model containing inline variant blocks .....	1-6
Code generation support for Variant Subsystems containing global signals .....	1-6
Preprocessor conditionals guard content inside and outside of function-call site .....	1-6
<b>Data, Function, and File Definition</b> .....	<b>1-9</b>
Function Interface: Return nonvoid type for scalar output of reusable functions .....	1-9
Utility to generate Simulink representations of <code>struct</code> and <code>enum</code> types defined by external C code .....	1-13
<b>Code Generation</b> .....	<b>1-14</b>
Cross-Release Code Integration: Reuse model reference code generated from previous releases .....	1-14

Code Replacement for Cast and Multiply Operations: Detect overflow and rounding mode equivalence for increased matches and code efficiency . . . . .	1-14
More information in code generation report summary . . . . .	1-15
Code Interface Report: Includes entry-point function for code generated from Reset Function block . . . . .	1-15
Shared utility memory section associated with subfunctions	1-15
Inline traceability for generated code . . . . .	1-16
Clear file section content from TLC file . . . . .	1-16
Identifier case control with token decorators and custom text token \$U . . . . .	1-17
\$U Token for Specifying Text in Generated Identifiers . . . . .	1-17
Case Control with Token Decorators . . . . .	1-17
Name change for AUTOSAR local temporary variables . . . . .	1-18
Additional checks against MISRA C:2012 guidelines in Code Generation Advisor . . . . .	1-18
<b>Deployment . . . . .</b>	<b>1-19</b>
TI Code Composer Studio (CCS): Generate projects for CCS versions 5 and 6 with Embedded Coder Target for TI C2000 . . . . .	1-19
Customize generated makefiles for S-Functions . . . . .	1-19
Release notes and workflow overview documentation added to AUTOSAR support package . . . . .	1-19
SPI and I2C blocks added to TI C2000 support package . . . . .	1-19
CCS v3.3 IDE automation support for TI C2000 has been removed . . . . .	1-20
Real-time multitasking profiling for TI C2000 . . . . .	1-20
TCP and UDP blocks added to STMicroelectronics STM32F746G-Discovery board . . . . .	1-20
MATLAB Coder PIL with STMicroelectronics STM32F4-Discovery Board . . . . .	1-21
External Mode and PIL supported over TCP/IP by STMicroelectronics STM32F746G-Discovery board . . . . .	1-23
Linux Support: Connect to ARM Cortex-M processor on Linux platform . . . . .	1-23
ARM Cortex-R optimized code . . . . .	1-23
Develop a Target for ARM Cortex-R processors . . . . .	1-24
Support for Wind River VxWorks RTOS will be removed . . . . .	1-24
<b>Performance . . . . .</b>	<b>1-25</b>

Data Copy Reduction: Generate fewer data copies and use less RAM for buses, data stores, and model blocks . . . . .	1-25
Data copy reduction for Bus Assignment block . . . . .	1-25
Data copy reduction for Data Store Read and Data Store Write blocks . . . . .	1-27
More efficient code for Model blocks . . . . .	1-30
Code Efficiency: Improve loop fusion for Sum of Elements blocks and generate less code for temporal logic in Stateflow . . . . .	1-34
Loop fusion for Sum of Elements blocks . . . . .	1-34
More efficient code for temporal logic in Stateflow . . . . .	1-37
Data copy reduction for Merge blocks . . . . .	1-37
More instances of buffer reuse for blocks and subsystems in a chain . . . . .	1-40
Buffer reuse for a chain of reusable and nonreusable subsystems . . . . .	1-41
Buffer reuse for a chain of reusable subsystems . . . . .	1-43
Improved buffer reuse due to changes in block execution order . . . . .	1-44
More efficient code for Bus Creator blocks . . . . .	1-46
Buffer reuse for Variant Source blocks . . . . .	1-47
<b>Verification . . . . .</b>	<b>1-50</b>
SIL and PIL Testing: Log signals inside exported functions and stream signals to Simulation Data Inspector during simulation . . . . .	1-50
Verification of PIL target connectivity configuration . . . . .	1-50
<b>Check bug reports for issues and fixes . . . . .</b>	<b>1-52</b>

## R2016b

<b>Code Generation from MATLAB Code . . . . .</b>	<b>2-2</b>
Static code metrics report for C++ code . . . . .	2-2
Verification of size_t and ptrdiff_t hardware settings . . . . .	2-2
Verification of PIL target connectivity configuration . . . . .	2-2
Optimization for array indexing in loops . . . . .	2-2

Reduction of the Intel Performance Primitives (IPP) code replacement libraries (CRL) . . . . .	2-3
<b>Model Architecture and Design</b> . . . . .	<b>2-4</b>
AUTOSAR Basic Software (BSW) Services: Simulate BSW including Diagnostic Event Manager (DEM) and NVRAM Manager (NvM) . . . . .	2-4
AUTOSAR Parameters: Model STD_AXIS and COM_AXIS lookup table parameters, export SwRecordLayouts, and apply SwAddrMethods . . . . .	2-4
AUTOSAR STD_AXIS and COM_AXIS lookup tables . .	2-5
AUTOSAR port-based and internal calibration parameters . . . . .	2-5
AUTOSAR SwRecordLayouts for lookup tables . . . . .	2-6
AUTOSAR SwAddrMethods for measurement and calibration tools . . . . .	2-6
AUTOSAR startup, reset, and shutdown modeling . . . . .	2-7
AUTOSAR external trigger event communication . . . . .	2-8
AUTOSAR support for JMAAB model architecture . . . . .	2-8
AUTOSAR ExplicitReceiveByVal data access mode for receiver ports . . . . .	2-9
AUTOSAR ModeSenderPorts and ModeSwitchPoints for application mode management . . . . .	2-10
AUTOSAR reference element definitions for sharing among components and services . . . . .	2-11
ERT Target Code Generation: Remove unreachable reset and disable functions to reduce dead code . . . . .	2-12
Conditional compile time check for imported macros with ImportedDefine custom storage class . . . . .	2-13
Additional guarding of global data for variant systems . . . .	2-13
<b>Data, Function, and File Definition</b> . . . . .	<b>2-18</b>
Simulink Function Code Interface: Configure generated C/C+ + function interfaces for Simulink Function and Function Caller blocks . . . . .	2-18
ERT default value for configuration parameter ParameterTunabilityLossMsg . . . . .	2-19
<b>Code Generation</b> . . . . .	<b>2-20</b>
Cross-Release Code Integration: Reuse code generated from earlier releases . . . . .	2-20



Compound Operation Code Replacement: Replace "Multiply Shift Right Arithmetic" and "Multiply Divide" in generated code with a single custom operation . . . . .	2-21
ARXML import/export and C code generation for latest AUTOSAR 4.2 and 3.2 standard revisions . . . . .	2-21
AUTOSAR code replacement library enhancements . . . . .	2-22
Static code metrics report for C++ code . . . . .	2-22
Static code metrics data produced by Polyspace . . . . .	2-22
Streamlined report pane for easier model configuration . . . . .	2-22
Improved traceability between model and code . . . . .	2-23
Code replacement enhancements . . . . .	2-24
\$I macro changed for argument names used as input and output . . . . .	2-24
Improved compliance with MISRA C:2012 Rules 10.1, 10.5, and 10.8 . . . . .	2-24
MISRA C:2012 Rule 10.1 . . . . .	2-25
MISRA C:2012 Rules 10.5 and 10.8 . . . . .	2-26
Improved compliance with MISRA AC AGC Rule 12.6 . . . . .	2-27
Use default installation folder on Windows system with ReFS file system . . . . .	2-28
<b>Deployment . . . . .</b>	<b>2-30</b>
Cortex-M7 Target Support Package: Generate code for STM32F746G-Discovery Board . . . . .	2-30
Added Embedded Coder Support Package for ARM Cortex-R Processors . . . . .	2-30
Improved External mode over serial communication . . . . .	2-31
New blocks added to TI's C2000 support package . . . . .	2-31
Change in name and the base product for the FRDM-K64F and the FRDM-KL25Z support packages . . . . .	2-31
Support for TI's C5000 DSPs has been removed . . . . .	2-32
Support for TI's C6000 has been removed . . . . .	2-32
Support for Wind River VxWorks RTOS will be removed . . . . .	2-32
Support for idelink_ert.tlc will be removed . . . . .	2-32
<b>Performance . . . . .</b>	<b>2-33</b>
Data Reuse and Memory Reduction: Reuse global data for nonreusable subsystems and reduce data copies with user-specified buffers . . . . .	2-33
Buffer reuse across nonreusable subsystems . . . . .	2-33
Buffer reuse for multiple signals in a path . . . . .	2-34

Code Optimizations: Generate more efficient code with select-assign-iterator pattern and matrix padding operations . . .	2-36
Data copy reduction for select-assign-iterator modeling pattern . . . . .	2-36
Data copy reduction for matrix padding operations . . .	2-38
Display of code execution times for model component . . . . .	2-40
More efficient code for array element assignments . . . . .	2-41
Loop fusion for nested <code>for</code> loops . . . . .	2-43
More efficient initialization code for root-level inports . . . . .	2-45
Loop fusion in <code>model_initialize</code> function . . . . .	2-45
One iteration variable for multiple <code>for</code> loops . . . . .	2-47
More efficient code for Boolean expressions . . . . .	2-49
<b>Verification . . . . .</b>	<b>2-51</b>
Verification of <code>size_t</code> and <code>ptrdiff_t</code> hardware settings . . . . .	2-51
Verification of PIL target connectivity configuration . . . . .	2-51
Signal range checking in SIL and PIL simulations . . . . .	2-51
SIL and PIL block support for Simulink Function and Function Caller blocks . . . . .	2-51
<b>Check bug reports for issues and fixes . . . . .</b>	<b>2-52</b>

## R2016a

<b>Code Generation from MATLAB Code . . . . .</b>	<b>3-2</b>
Export data by using <code>ExportedDefine</code> storage class . . . . .	3-2
SIL execution returns standard output and standard error streams . . . . .	3-2
<b>Model Architecture and Design . . . . .</b>	<b>3-4</b>
Compile-Time Dimensions: Generate compiler directives ( <code>#define</code> ) for implementing signal dimensions . . . . .	3-4
Compile-Time Variants: Generate compiler directives ( <code>#if</code> ) for variant choices specified with Variant Source and Variant Sink blocks . . . . .	3-5
C++ Code Generation: Use referenced models with multitasking, export-functions, and virtual buses . . . . .	3-5

MISRA C:2012 Compliance: Check block names and Assignment blocks by using the Model Advisor . . . . .	3-6
AUTOSAR Round Trip: Automate model additions for update and merge of ARXML files . . . . .	3-6
Comment change in generated code . . . . .	3-7
Variants in AUTOSAR component modeling . . . . .	3-7
AUTOSAR variants in ports and runnables . . . . .	3-8
AUTOSAR variants in array sizes . . . . .	3-8
AUTOSAR DataReceivedEvents for receiver ports in ImplicitReceive data access mode . . . . .	3-9
AUTOSAR LiteralPrefix for enumerations in IncludedDataTypeSets . . . . .	3-10
Programmatic validation and synchronization of AUTOSAR model configurations . . . . .	3-10
<b>Data, Function, and File Definition . . . . .</b>	<b>3-11</b>
In/Out Arguments: Specify same variable name for in/out arguments of MATLAB Function and Model blocks . . . . .	3-11
Buffer reuse across Model blocks . . . . .	3-11
Buffer reuse across MATLAB Function blocks . . . . .	3-14
Custom Storage Class Type <code>AccessFunction</code> . . . . .	3-15
Creation of custom storage classes for macros defined by compiler options . . . . .	3-15
Generation of ERT S-functions that represent variant controls as preprocessor conditionals . . . . .	3-16
<b>Code Generation . . . . .</b>	<b>3-17</b>
Default style C++ interface replaces the void-void style C++ interface . . . . .	3-17
Compiler warning limitation removed for portable word sizes in SIL simulations . . . . .	3-17
AUTOSAR arxml round trip . . . . .	3-18
CompuMethods with LINEAR and TEXTTABLE COMPU- SCALEs . . . . .	3-19
PredefinedVariants import and export . . . . .	3-19
Enhanced control of AUTOSAR package path specification . . . . .	3-20
Improved AUTOSAR library support for Mfx functions . . . . .	3-20
AUTOSAR target no longer supports building wrapper subsystem as AUTOSAR SW-Component . . . . .	3-21
Root model name in generated identifier for shared utility files . . . . .	3-21

Improved configuration parameter defaults for Embedded Coder targets .....	3-21
Streamlined code generation panes for easier model configuration .....	3-22
Code Generation Pane .....	3-23
Code Generation > Interface Pane .....	3-23
Code Generation > Debug Pane .....	3-24
Code Generation > Verification Pane .....	3-24
Data Import/Export Pane .....	3-24
Diagnostics Pane .....	3-25
Diagnostics > Data Validity Pane .....	3-25
Diagnostics > Saving Pane .....	3-25
Diagnostics > Solver Pane .....	3-25
Optimization Pane .....	3-26
Optimization > Signals and Parameters Pane .....	3-26
Simulation Target Pane .....	3-26
Simulation Target > Custom Code Pane .....	3-26
Simulation Target > Symbols Pane .....	3-27
Build button removed from Configuration Parameters dialog box .....	3-27
Improved web view for code generation report .....	3-27
Dependent parameters not added to custom code generation objective .....	3-28
Removal of leading underscore character in macro type definitions .....	3-28
<b>Deployment .....</b>	<b>3-30</b>
Hardware implementation parameters enabled by default ..	3-30
MATLAB Coder PIL With ARM Cortex-A: Verify and profile ARM optimized code with Altera SoC and Xilinx Zynq hardware .....	3-30
Updates to support package for Texas Instruments C2000 processors .....	3-30
Support package for Freescale FRDM-K64F board .....	3-31
Support for TI's C5000 DSPs will be removed .....	3-31
Support for TI's C6000 DSPs will be removed .....	3-31
Change in base product for ARM Cortex-Based VEX Microcontroller support package .....	3-31
<b>Performance .....</b>	<b>3-32</b>

Data Buffer Reuse: Use same variable for multiple signals in a path by using the same Reusable storage class specification . . . . .	3-32
Reuse input, output, and state of Delay block . . . . .	3-32
Initialization code occurs once after start code in model_initialize function . . . . .	3-32
Reset function improves initialization code optimization . . .	3-36
Removal of unnecessary rtmIsFirstInitCond flag . . . . .	3-38
Optimized code for models containing logical operator blocks	3-40
Improved code for conditional expressions involving Boolean expressions . . . . .	3-41
memset Optimization for more scenarios . . . . .	3-43
memset optimization for assigning a constant value to fields of a structure array . . . . .	3-44
memset optimization for array element assignments . .	3-45
memset optimization for consecutive assignments that define a continuous write . . . . .	3-47
Changes to meaning of createCRLEntry wildcard syntax for fixed-point data . . . . .	3-49
Code replacements involving root-level I/O variables and data alignment . . . . .	3-50
<b>Verification . . . . .</b>	<b>3-52</b>
SIL/PIL Data Access: Use vector Get/Set custom storage class and C++ parameter access methods . . . . .	3-52
SIL/PIL support for variant condition propagation . . . . .	3-52
SIL simulation returns standard output and standard error streams . . . . .	3-52
Linux SIL/PIL support for LDRA Testbed . . . . .	3-53
<b>Check bug reports for issues and fixes . . . . .</b>	<b>3-54</b>

## R2015aSP1

### Bug Fixes

<b>Check bug reports for issues and fixes . . . . .</b>	<b>4-2</b>
---	------------

<b>Code Generation from MATLAB Code</b> .....	<b>5-2</b>
MATLAB Coder Storage Classes: Easily import and export data by using storage classes .....	<b>5-2</b>
MATLAB Coder PIL With ARM Cortex-A: Verify and profile ARM optimized code with BeagleBone Black hardware . . .	<b>5-3</b>
Code generation assumptions verified during PIL execution .	<b>5-3</b>
Control of signed right shifts in generated code .....	<b>5-4</b>
Detection of multiword operations .....	<b>5-5</b>
<b>Model Architecture and Design</b> .....	<b>5-6</b>
MISRA-C 2012: Comply with mandatory and required rules .	<b>5-6</b>
AUTOSAR 4.1.3 and 4.2: Import and export ARXML and generate code for latest AUTOSAR standard .....	<b>5-7</b>
AUTOSAR sender-receiver modeling .....	<b>5-7</b>
IsUpdated API for receiver ports .....	<b>5-8</b>
Data element invalidation policies on sender ports . . . .	<b>5-8</b>
End-to-end protection for sender and receiver ports . . . .	<b>5-8</b>
DataReceiveErrorEvent for receiver ports .....	<b>5-9</b>
Rte_IWriteRef for sender ports .....	<b>5-9</b>
AUTOSAR client-server modeling .....	<b>5-10</b>
AUTOSAR error status .....	<b>5-10</b>
AUTOSAR NVRAM memory services .....	<b>5-11</b>
AUTOSAR nonvolatile data communication modeling . . . . .	<b>5-12</b>
AUTOSAR component behavior modeling .....	<b>5-14</b>
IRVs in feedback loops .....	<b>5-14</b>
Constant memory with const or volatile type qualifiers	<b>5-15</b>
AUTOSAR COM_AXIS lookup table modeling .....	<b>5-15</b>
Embedded Coder model templates .....	<b>5-16</b>
Removal of uncalled <code>Disable</code> functions from generated code	<b>5-16</b>
Enhancement to option for generating preprocessor conditionals .....	<b>5-17</b>
<b>Data, Function, and File Definition</b> .....	<b>5-19</b>
Tokenized function names for custom storage class <code>GetSet</code> .	<b>5-19</b>
<b>Code Generation</b> .....	<b>5-20</b>

Embedded Coder Quick Start: Quickly configure model to generate reusable and efficient code . . . . .	5-20
Internationalization: Generate and review code containing mixed languages for different locales . . . . .	5-20
MISRA C:2012 code generation objective . . . . .	5-21
Compatibility Considerations . . . . .	5-21
AUTOSAR arxml round-trip . . . . .	5-21
Editable AUTOSAR display format for calibration . . . . .	5-22
Configurable export of AUTOSAR internal data constraints . . . . .	5-22
AUTOSAR reference bases . . . . .	5-22
AUTOSAR-typed per-instance memory import . . . . .	5-23
Toolchain controls for AUTOSAR code generation . . . . .	5-24
AUTOSAR RTE file generation enhanced for SIL and PIL . . . . .	5-24
Lookup table blocks with new even spacing specification generate AUTOSAR compatible IFX library routines . . . . .	5-26
Control use of signed shifts in generated code . . . . .	5-26
Code generation report with operator traceability . . . . .	5-26
<b>Deployment . . . . .</b>	<b>5-27</b>
Hardware Implementation Selection: Quickly generate code for popular embedded processors . . . . .	5-27
Code Replacement Tool uses simplified specification . . . . .	5-29
Code replacement support for new lookup table breakpoint specification . . . . .	5-29
Support for Analog Devices VisualDSP++ will be removed . . . . .	5-30
<b>Performance . . . . .</b>	<b>5-31</b>
RAM/ROM Optimization Improvements: Generate more efficient code using reusable storage class and converting data copies to pointer assignments . . . . .	5-31
Reuse input and output of a block or subsystem . . . . .	5-31
More efficient code for large data sets . . . . .	5-31
Live Execution Profiling: View PIL profile results during runtime . . . . .	5-33
Enhanced support for buffer reuse at the root-level input and output ports . . . . .	5-33
Reusable custom storage class for model block input and output ports . . . . .	5-33
Combined input and output arguments with function prototype control . . . . .	5-35
More efficient code for small subsystems . . . . .	5-36

More efficient code for <code>Simulink.Bus</code> objects . . . . .	5-38
Enhanced local variable reuse . . . . .	5-40
Enhanced consolidation of <code>for</code> loops . . . . .	5-42
<b>Verification</b> . . . . .	<b>5-45</b>
Faster SIL and PIL Verification Workflow . . . . .	5-45
Code generation assumptions verified during PIL simulation	5-45
SIL and PIL support for C++ class root-level I/O access	
methods . . . . .	5-45
Removal of <code>Generate code only</code> parameter restriction . .	5-46
Removal of scheduling limitations that caused algebraic	
loops . . . . .	5-46
<b>Check bug reports for issues and fixes</b> . . . . .	<b>5-2</b>

## R2015a

<b>Code Generation from MATLAB Code</b> . . . . .	<b>6-2</b>
Indent style and size control for generated C/C++ code . . . . .	6-2
Improved MISRA-C compliance for bitwise operations on signed	
integers . . . . .	6-3
Improved MISRA-C type cast compliance . . . . .	6-4
<b>Model Architecture and Design</b> . . . . .	<b>6-6</b>
AUTOSAR improvements including multi-runnable modeling	
and code efficiency . . . . .	6-6
Combined input/output arguments with function prototype	
control . . . . .	6-6
Improved MISRA-C compliance for bitwise operations on signed	
integers . . . . .	6-7
AUTOSAR multi-runnable modeling using Simulink rate-based	
multitasking . . . . .	6-7
Enhanced modeling with AUTOSAR system constants . . . . .	6-8
AUTOSAR <code>CompuMethod</code> enhancements . . . . .	6-8
Preprocessor conditionals for single variant choice . . . . .	6-9
<b>Data, Function, and File Definition</b> . . . . .	<b>6-10</b>



Control of Boolean and data type limit identifiers in generated code .....	6-10
Names of built-in storage classes reserved .....	6-10
<b>Code Generation</b> .....	<b>6-12</b>
Simplified Code Replacement Library specification plus more replacements involving integer operations .....	6-12
Simplified Code Replacement Library specification ...	6-12
More replacements involving integer operations .....	6-12
Improved readability for shared header file 'rtwtypes.h'	6-13
New and enhanced Model Advisor checks for MISRA-C compliance .....	6-14
Improved traceability for AUTOSAR RTE implicit read .....	6-15
Configurable aliveTimeout value for AUTOSAR ports .....	6-16
AUTOSAR calibration parameter export for COM_AXIS lookup tables .....	6-16
Fixed-point scaling information in Code Interface Report ..	6-17
Unsigned integer minimum data limit identifiers .....	6-17
Default iteration variable data type .....	6-18
<b>Deployment</b> .....	<b>6-20</b>
Code Replacement Viewer enhanced .....	6-20
Model configuration parameter considered for division operator code replacements .....	6-20
Lookup table algorithm parameter specification enhancements .....	6-20
Header file for Basic Linear Algebra Subroutine (BLAS) multiplication function code replacement example changed .....	6-21
Code replacement detection of overflow and rounding mode equivalence .....	6-21
Feature being removed in a future release .....	6-21
<b>Performance</b> .....	<b>6-22</b>
More efficient code involving model references, unit delays, and global data references .....	6-22
Reusable custom storage class for Model block input/output ports .....	6-22
Reuse input, output, and state of Unit Delay block ...	6-22
Enhanced variable reuse optimizations .....	6-23
Strategic caching of global variable references .....	6-25

Enhanced global variable localization optimizations . . .	6-26
Conditional compilation of Data Store Memory block memory definition and declaration . . . . .	6-28
Ternary Boolean expressions transformed into assignment statements . . . . .	6-30
<b>Verification . . . . .</b>	<b>6-31</b>
SIL/PIL for protected models and SIL source code debugging using Microsoft Visual Studio Express . . . . .	6-31
SIL/PIL for protected models . . . . .	6-31
SIL source code debugging using Microsoft Visual Studio Express . . . . .	6-32
Model block SIL/PIL parameter renamed . . . . .	6-32
ERT S-Function block no longer supported for AUTOSAR . .	6-32
SIL/PIL support for replacing <code>boolean</code> data type with <code>int8</code>	6-32
SIL/PIL support for generated access methods for C++ model class root-level I/O signals . . . . .	6-33
<b>Check bug reports for issues and fixes . . . . .</b>	<b>6-34</b>

## R2014b

<b>Code Generation from MATLAB Code . . . . .</b>	<b>7-2</b>
Processor-in-the-loop (PIL) verification and execution profiling for MATLAB code . . . . .	7-2
Software-in-the-loop verification improvements for MATLAB Coder . . . . .	7-2
Additional options for custom banners and comments in C and C++ code generated from MATLAB code . . . . .	7-3
Highlighting of potential data type issues in code generation reports . . . . .	7-4
<b>Model Architecture and Design . . . . .</b>	<b>7-8</b>
AUTOSAR targeting updates including 4.1 ARXML, client/ server with Simulink Functions, multi-instance components, and IFL/IFX libraries . . . . .	7-8
AUTOSAR client and server modeling . . . . .	7-9

Global From and Goto blocks for AUTOSAR modeling . . . . .	7-9
AUTOSAR IRV branch from outport signal allowed outside runnable . . . . .	7-9
<b>Data, Function, and File Definition . . . . .</b>	<b>7-12</b>
Constant sample time limitation for AUTOSAR models . . . .	7-12
Iteration variable in For Iterator block uses signal name . . .	7-12
Data type replacement specification can be used across models . . . . .	7-12
Definition file for grouped custom storage classes . . . . .	7-12
Type definition location for custom storage classes . . . . .	7-13
GetFunction and SetFunction included in checks for identifier clash . . . . .	7-13
<b>Code Generation . . . . .</b>	<b>7-14</b>
Enhanced reporting of eliminated blocks . . . . .	7-14
Improved MISRA-C type cast compliance . . . . .	7-14
Support Package for AUTOSAR Standard . . . . .	7-14
AUTOSAR help navigation enhancements . . . . .	7-15
Support for AUTOSAR Release 4.1 . . . . .	7-16
AUTOSAR 4.1 ARXML and C code generation . . . . .	7-16
AUTOSAR 4.1 InitEvent support . . . . .	7-16
AUTOSAR 4.1 provide-require port support . . . . .	7-17
Multi-instance AUTOSAR atomic software components . . . .	7-17
AUTOSAR arxml import and export . . . . .	7-17
AUTOSAR R4.x compliant data type support . . . . .	7-17
AUTOSAR CompuMethod control . . . . .	7-19
Improved AUTOSAR package configuration . . . . .	7-21
AUTOSAR calibration component export . . . . .	7-21
Simulink Min and Max mapping to AUTOSAR physical data constraints . . . . .	7-22
AUTOSAR addPackageableElement replaces add*Interface functions . . . . .	7-22
Code generation report with enhanced navigation and integrated access to code metrics data . . . . .	7-23
Updated license requirements for viewing code generation report . . . . .	7-23
Option for doxygen style comments in generated code . . . . .	7-24
Dynamic memory allocation parameters renamed . . . . .	7-25
Template makefile compatibility with execution time profiling . . . . .	7-25

Intel Performance Primitives (IPP) platform-specific code replacement libraries for cross-platform code generation .	7-25
<b>Deployment</b> . . . . .	<b>7-27</b>
Embedded Coder support packages for AUTOSAR, TI Concerto, and Freescale FRDM-KL25Z . . . . .	7-27
Relational operator replacement . . . . .	7-27
Code replacement involving vector and matrix data . . . . .	7-27
Trigonometry function replacement . . . . .	7-27
Replacement of shift and cast operations involving vector and matrix operands . . . . .	7-28
Algorithm specification for addition and subtraction operator replacement . . . . .	7-28
Improved code replacement with output type cast absorption	7-29
Lookup table function code replacement extended to 30 dimensions . . . . .	7-29
Rounding mode support for lookup table function replacement . . . . .	7-30
Algorithm parameter value sets in code replacement table entries . . . . .	7-30
coder.replace support for functions specified with varargin input variable . . . . .	7-30
Documentation installation with hardware support package	7-31
Support package for Altera SoC platform . . . . .	7-31
Support package for BeagleBone Black hardware . . . . .	7-31
Support for Eclipse IDE has been removed . . . . .	7-31
Support for Green Hills MULTI IDE has been removed . . . .	7-32
Support for Texas Instruments C5000 DSPs will be removed	7-32
<b>Performance</b> . . . . .	<b>7-33</b>
Reduced RAM and faster execution for modeling patterns including select-assign-iterate blocks, subsystem interfaces, and model references . . . . .	7-33
Example Model . . . . .	7-33
In-place assignments for select-assign-iterate pattern .	7-35
Subsystem signal information . . . . .	7-36
Variable reuse around call site . . . . .	7-37
Global variable localization optimizations . . . . .	7-38
<b>Verification</b> . . . . .	<b>7-40</b>
Top-model code testing with Model block SIL and PIL . . . . .	7-40

SIL/PIL support for Simulink Function and Function Caller blocks . . . . .	7-40
SIL debugging support for Linux . . . . .	7-41
PIL support for test hardware approach . . . . .	7-41
SIL/PIL support for model initialization dynamic memory allocation . . . . .	7-41
<b>Check bug reports for issues and fixes . . . . .</b>	<b>7-42</b>

## R2014a

<b>Code Generation from MATLAB Code . . . . .</b>	<b>8-2</b>
Template to customize code generation output for MATLAB Coder . . . . .	8-2
In-place function replacement with coder.replace in MATLAB . . . . .	8-2
Single-line (//) comment style available for generated code . . . . .	8-2
Software-in-the-loop verification for MATLAB Coder . . . . .	8-3
Change of default value for MATLABFcnDesc . . . . .	8-4
<b>Model Architecture and Design . . . . .</b>	<b>8-6</b>
Capability to merge AUTOSAR authoring tool changes into Simulink models as part of round-trip iterations . . . . .	8-6
AUTOSAR 4.0 static and constant memory, AUTOSAR-typed per-instance memory, and VariationPointProxy . . . . .	8-8
Static and constant memory . . . . .	8-8
AUTOSAR-typed per-instance memory . . . . .	8-8
Variation point proxy . . . . .	8-8
Specify AUTOSAR runnable symbol name distinct from short-name . . . . .	8-9
Improved AUTOSAR arxml support for measurement and calibration . . . . .	8-9
AUTOSAR data dictionary support . . . . .	8-10
Configure AUTOSAR Interface button removed from AUTOSAR Code Generation Options . . . . .	8-10
Subsystem methods of AUTOSAR arxml.importer class removed . . . . .	8-11

<b>Data, Function, and File Definition</b> .....	<b>8-12</b>
Custom storage class and optimized class declarations for C++ class code generation .....	<b>8-12</b>
Custom storage class support for C++ class code generation .....	<b>8-12</b>
Improved code for C++ model class declarations .....	<b>8-12</b>
Constant sample time limitations for root-level Outport blocks .....	<b>8-12</b>
Example model <code>rtwdemo_cppencap</code> renamed to <code>rtwdemo_cppclass</code> .....	<b>8-13</b>
Unit Delay block optimization .....	<b>8-13</b>
 <b>Code Generation</b> .....	 <b>8-14</b>
In-place function replacement with <code>coder.replace</code> in MATLAB and lookup table code replacement for Simulink .....	<b>8-14</b>
In-place function replacement with <code>coder.replace</code> in MATLAB .....	<b>8-14</b>
Lookup table code replacement for Simulink .....	<b>8-14</b>
Global variable usage available in the static code metrics report .....	<b>8-14</b>
Single-line ( <code>//</code> ) comment style available for generated code ..	<b>8-15</b>
Code indentation support for <code>namespace</code> declarations in generated code .....	<b>8-15</b>
AUTOSAR C code generation enhancements .....	<b>8-16</b>
Static main program module for C++ class code generation .	<b>8-17</b>
Error message for data type replacement and classic call interface conflict .....	<b>8-17</b>
 <b>Deployment</b> .....	 <b>8-18</b>
ARM Cortex-A optimized code generation using Ne10 library	<b>8-18</b>
Lookup table code replacement for Simulink .....	<b>8-18</b>
Replacement of functions that take vector and matrix arguments .....	<b>8-19</b>
Logical data type support for arguments of replaced functions .....	<b>8-19</b>
Code replacement data alignment for complex types .....	<b>8-19</b>
Intel IPP (ANSI) and Intel IPP (ISO) code replacement libraries are combined .....	<b>8-20</b>
Support for Eclipse IDE will be removed .....	<b>8-20</b>
Support for Green Hills MULTI IDE will be removed .....	<b>8-21</b>
Support package for ARM Cortex-A processors .....	<b>8-21</b>

Support package for Texas Instruments C6000 processors . . .	8-21
Updates to support package for Texas Instruments C2000 processors . . . . .	8-22
Updates to support package for Xilinx Zynq-7000 platform .	8-22
Updates to support package for STMicroelectronics STM32F4 Discovery board . . . . .	8-23
Wind River Tornado (VxWorks 5.x) example main program option to be removed in future release . . . . .	8-23
<b>Performance . . . . .</b>	<b>8-25</b>
Additional options for reuse of global variables . . . . .	8-25
Enhanced global variable optimization options . . . . .	8-25
for loops used to initialize arrays to zero . . . . .	8-25
<b>Verification . . . . .</b>	<b>8-27</b>
Software-in-the-loop simulation for physical models . . . . .	8-27
SIL verification for subsystem code generation . . . . .	8-27
SIL and PIL support for fixed-point data type override . . . .	8-30
SIL and PIL support for Invoke AUTOSAR Server Operation block . . . . .	8-30
SIL and PIL support for structure parameters with storage class <code>SimulinkGlobal</code> . . . . .	8-30
Model block SIL and PIL with export-function and asynchronous function-call models . . . . .	8-30
Model block SIL and PIL with disabled inline parameters . .	8-31
SIL and PIL block improvements . . . . .	8-32
<b>Check bug reports for issues and fixes . . . . .</b>	<b>8-33</b>

## R2013b

<b>Code Generation from MATLAB Code . . . . .</b>	<b>9-2</b>
Software-in-the-loop verification for MATLAB Coder . . . . .	9-2
Custom generated identifiers for <code>emxArray</code> utility functions .	9-2
<b>Model Architecture and Design . . . . .</b>	<b>9-4</b>

Enhanced modeling of AUTOSAR runnables and modes, and improved ARXML import of internal behavior . . . . .	9-4
Enhanced modeling and simulation of AUTOSAR multiple runnables . . . . .	9-4
Enhanced ARXML import of AUTOSAR software component internal behavior . . . . .	9-4
Ability to model AUTOSAR mode receiver ports and events . . . . .	9-5
AUTOSAR dual-scaled parameter . . . . .	9-5
Programmatic interface for configuring AUTOSAR properties and Simulink-AUTOSAR mapping . . . . .	9-5
Reorganization of Model Advisor Embedded Coder checks . . . . .	9-6
Model Advisor fixed-point checks with additional coverage and optimization awareness . . . . .	9-7
Protected model Web view . . . . .	9-7
RTW.AutosarInterface class to be removed in a future release . . . . .	9-7
Subsystem methods of arxml.importer class to be removed in a future release . . . . .	9-8
<b>Data, Function, and File Definition . . . . .</b>	<b>9-9</b>
Simplified global types file <code>rtwtypes.h</code> with invariant content . . . . .	9-9
C++ encapsulation support for name space control and template-based file customization . . . . .	9-9
Name space control for scoping C++ encapsulated model classes . . . . .	9-9
Template-based customization of encapsulated C++ header and source files . . . . .	9-10
Shared utility naming control . . . . .	9-10
Expanded support for identifier names . . . . .	9-11
Terminate function setting honored for subsystems and referenced models . . . . .	9-11
<b>Code Generation . . . . .</b>	<b>9-12</b>
Support for AUTOSAR release 4.0.3 XML and generated code . . . . .	9-12
Indent style and size control for code generation . . . . .	9-12
Subsystem functions return value in generated code . . . . .	9-12
Model reference step function void input and output arguments . . . . .	9-13



<b>Deployment</b> .....	<b>9-14</b>
ARM Cortex-M optimized code with STM32F4-Discovery board example .....	<b>9-14</b>
Support package for ARM Cortex processors .....	<b>9-14</b>
Support package for STMicroelectronics STM32F4- Discovery Board .....	<b>9-14</b>
Wind River VxWorks 6.9 support .....	<b>9-15</b>
Compatibility Considerations .....	<b>9-15</b>
Support package for Texas Instruments C2000 processors ..	<b>9-16</b>
Compatibility Considerations .....	<b>9-16</b>
Coder Target pane in Configuration Parameters dialog box .	<b>9-17</b>
ZedBoard hardware support .....	<b>9-18</b>
Simplified multi-instance code interface and dynamic memory allocation for ERT targets .....	<b>9-18</b>
Addition and Subtraction Operator Code Replacement Assumes Cast-Before-Operation Behavior .....	<b>9-20</b>
<b>Performance</b> .....	<b>9-22</b>
Reusable custom storage class to reduce root I/O memory ..	<b>9-22</b>
Subsystem functions reused independently of output connection .....	<b>9-22</b>
<b>Verification</b> .....	<b>9-23</b>
SIL and PIL support fixed-point data types wider than 32 bits .....	<b>9-23</b>
SIL and PIL protected model support .....	<b>9-24</b>
Code execution profiling improvements .....	<b>9-24</b>
Standalone code generation with function profiling ...	<b>9-24</b>
Display of code section invocations .....	<b>9-24</b>
SampleOffset and SamplePeriod removed .....	<b>9-25</b>
<b>Check bug reports for issues and fixes</b> .....	<b>9-26</b>

## R2013a

<b>Code Generation from MATLAB Code</b> .....	<b>10-2</b>
---	-------------

Improved code replacement traceability for MATLAB code generation . . . . .	10-2
Static code metrics report for MATLAB Coder . . . . .	10-2
<b>Model Architecture and Design . . . . .</b>	<b>10-4</b>
AUTOSAR user interface and round trip ARXML file import and export improvements . . . . .	10-4
Improved graphical user interfaces for AUTOSAR configuration . . . . .	10-4
Round-trip preservation of AUTOSAR elements and UUIDs . . . . .	10-6
Code generation for variable-size scalar signals . . . . .	10-7
<b>Data, Function, and File Definition . . . . .</b>	<b>10-8</b>
Shortened system-generated identifier names . . . . .	10-8
Improved data initialization with custom storage classes . . . . .	10-8
Default specification for global types . . . . .	10-8
Subsystem block parameter Function packaging option renamed . . . . .	10-8
<b>Code Generation . . . . .</b>	<b>10-9</b>
Model Advisor checks for code generation . . . . .	10-9
<b>Deployment . . . . .</b>	<b>10-10</b>
Concurrent execution API to target embedded multicore platforms . . . . .	10-10
Semaphore and mutex code replacement for multicore target environments . . . . .	10-10
Hardware timer function replacement . . . . .	10-10
Hardware configuration relocation from Target Preferences block to Configuration Parameters dialog box . . . . .	10-11
Downloadable support and blocks for Analog Devices DSPs . . . . .	10-12
Texas Instruments C2000 Clocking Options . . . . .	10-12
Support for Texas Instruments C2802x and Texas Instruments C2803x variants . . . . .	10-13
Downloadable support and blocks for Xilinx Zynq-7000 platform . . . . .	10-14
Support ending for Eclipse IDE in a future release . . . . .	10-14
Support ending for remoteBuild method in a future release . . . . .	10-15

<b>Performance</b> .....	<b>10-16</b>
Optimized function arguments for nonreusable subsystems	<b>10-16</b>
Reduced data copies for tunable parameter expressions ...	<b>10-16</b>
Removal of unused global variables .....	<b>10-17</b>
<b>Verification</b> .....	<b>10-18</b>
Debugging during SIL simulations .....	<b>10-18</b>
Simulation of multiple SIL Model blocks in a top model ...	<b>10-18</b>
API for testing <code>rtiostream</code> communications .....	<b>10-18</b>
SIL and PIL support for targets with multicore processors .	<b>10-19</b>
Additional code annotation for justifying Polyspace checks	<b>10-20</b>
Code execution profiling improvements .....	<b>10-20</b>
Comprehensive measurement and reporting of function execution times .....	<b>10-20</b>
Viewing and comparing execution time plots with the Simulation Data Inspector .....	<b>10-20</b>
Specification of hardware timer through the Code Replacement Tool .....	<b>10-21</b>
Code-to-model traceability links for reusable subsystems in libraries .....	<b>10-21</b>
<b>Check bug reports for issues and fixes</b> .....	<b>10-23</b>

## R2012b

<b>Cyclomatic complexity measurement in static code metrics report</b> .....	<b>11-2</b>
<b>Custom code substitution for MATLAB functions using code replacement libraries</b> .....	<b>11-2</b>
<b>SIL and PIL support for signal logging, encapsulated C++, and AUTOSAR calibration parameters</b> .....	<b>11-2</b>
Signal logging for SIL and PIL simulations .....	<b>11-3</b>
Use SIL and PIL simulations to verify encapsulated C++ code .....	<b>11-3</b>
Improved SIL and PIL verification for AUTOSAR-compliant code .....	<b>11-3</b>

<b>AUTOSAR 4.0 nonscalar data support</b> .....	11-4
<b>Code annotation for justifying Polyspace checks</b> .....	11-4
<b>Texas Instruments Code Composer Studio IDE 5.1 support</b> .....	11-4
<b>External mode support for ERT targets with static main</b> ..	11-5
<b>Downloadable support for Green Hills MULTI</b> .....	11-5
<b>Support for Texas Instruments C2806x processors</b> .....	11-6
<b>Performance enhancement of Simulink data objects</b> .....	11-7
<b>AUTOSAR software component import and export enhancements</b> .....	11-8
Import validation .....	11-8
Faster import and export of arxml files .....	11-8
Explicit access mode for AUTOSAR Sender and Receiver ports .....	11-9
Import port-based calibration parameters .....	11-9
<b>Highlight virtual blocks in model Web view of code generation report</b> .....	11-9
<b>Code Execution Profiling Improvements</b> .....	11-9
Updated Code Execution Profiling API .....	11-9
Code Execution Profiling Supports Single Object Output ..	11-12
<b>Incremental Compilation with Changes in Code Coverage Settings</b> .....	11-13
<b>Check bug reports for issues and fixes</b> .....	11-14

## R2012a

<b>AUTOSAR Enhancements</b> .....	12-2
AUTOSAR Release 4.0 .....	12-2

Support for Schema 2.0 Removed .....	12-2
<b>Code Efficiency Enhancements</b> .....	12-2
For Each Subsystem Loop Bound Passed by Value .....	12-2
Fully Inlined S-functions from Legacy Code Tool .....	12-3
Element-Wise Operations as Inputs to Intrinsic Functions .	12-3
<b>Enhancements to Custom Storage Classes in Simulink and mpt Packages</b> .....	12-4
<b>Code Generation Report Includes Simulink Web View</b> ....	12-4
<b>LDRA Testbed Code Coverage Annotations in Code Generation Report</b> .....	12-5
<b>Generated Identifiers Enhancements</b> .....	12-5
Simplified Identifiers for Model Reference Code .....	12-5
Consistent Identifiers for Comparing Generated Code .....	12-5
<b>Code Replacement Enhancements</b> .....	12-6
Target Function Libraries Renamed to Code Replacement Libraries .....	12-6
Enhanced Code Replacement Traceability .....	12-7
Code Replacement Support for Simulink Matrix Division and Inversion Operators .....	12-8
Code Replacement Support for MATLAB Coder fix, hypot, round, and sign Functions .....	12-8
Integer Functions Now Return Real-World Values .....	12-8
<b>SIL and PIL Enhancements</b> .....	12-8
SIL and PIL Test Harness Files in Code Generation Report .	12-9
PIL Support for Code Coverage with LDRA Testbed .....	12-10
Seamless Switching Between SIL and PIL for Top-Model and Model Block .....	12-10
Enhanced Hardware Implementation Support .....	12-10
Top-Model Output Limitations Removed .....	12-11
Model Block SIL/PIL Support for Absolute Time .....	12-12
<b>Changes for ERT and ERT-Based Targets</b> .....	12-12
<b>Changes for Embedded IDEs and Embedded Targets</b> ....	12-13
Support Added for GCC 4.4 on Host Computers Running Linux with Eclipse IDE .....	12-13

Support Added for Using Processor-in-the-Loop (PIL) with Serial Communication Interface (SCI) for TI C2000 Processors . . . . .	12-13
Support Removed for Freescale MPC5xx . . . . .	12-14
Limitation: Parallel Builds Not Supported for Embedded Targets . . . . .	12-14
<b>New and Enhanced Demos . . . . .</b>	<b>12-14</b>
<b>Check bug reports for issues and fixes . . . . .</b>	<b>12-16</b>

## R2011b

<b>Static Code Metrics in Code Generation Report . . . . .</b>	<b>13-2</b>
<b>AUTOSAR Enhancements . . . . .</b>	<b>13-2</b>
Import and Export of AUTOSAR Sensor/Actuator Components . . . . .	13-2
Improved Simulink Library Support for Multiple Runnables . . . . .	13-2
AUTOSAR Schema Version 3.2 . . . . .	13-3
Export AUTOSAR XML as Single File . . . . .	13-3
<b>SIL and PIL Enhancements . . . . .</b>	<b>13-3</b>
Code Execution Profiling of Functions in Subsystems and Model Blocks . . . . .	13-3
Code Coverage with LDRA Testbed . . . . .	13-3
BitField and GetSet Custom Storage Classes . . . . .	13-3
Model Blocks with Variable-Size Signals . . . . .	13-4
Verification of Generated C++ Code . . . . .	13-4
<b>Generate Multitasking Code for Concurrent Execution on   Multicore Processors . . . . .</b>	<b>13-4</b>
<b>Changes for Embedded IDEs and Embedded Targets . . . . .</b>	<b>13-5</b>
64-bit Version of Embedded Coder Supports Analog Devices VisualDSP++ and Texas Instruments Code Composer Studio 3.3 and 4.0 . . . . .	13-5
Support Added for Wind River VxWorks 6.8 . . . . .	13-6

Support Added for Serial Communications Interface with Processor-in-the-loop (PIL) for Texas Instruments™ C28035 and C28335 . . . . .	13-6
New Target Function Library for Intel IPP/SSE (GNU) . . . .	13-6
Support Added for Single Instruction Multiple Data (SIMD) with ARM Cortex-A8, ARM Cortex-A9 , and Intel Processors . . . . .	13-6
Support Removed for Altium TASKING . . . . .	13-7
Support Removed for Infineon C166 . . . . .	13-7
Support Ending for Green Hills MULTI in a Future Release . . . . .	13-7
Support Ending for Freescale MPC5xx in a Future Release .	13-7
<b>Saturation Control of Stateflow Data . . . . .</b>	<b>13-7</b>
<b>Custom Storage Class Properties for Managing Data     Ownership and Definition . . . . .</b>	<b>13-8</b>
<b>Export Data Declarations to Shared Header File for Code     Generation with Model Reference . . . . .</b>	<b>13-9</b>
<b>Target Function Library Code Replacement     Enhancements . . . . .</b>	<b>13-9</b>
Code Replacement Tool for Creating and Managing TFL Tables . . . . .	13-9
Ability to Align Data Objects to TFL-Specified Boundaries to Boost Code Performance . . . . .	13-10
Support for Replacing Element-wise Matrix Multiply . . . .	13-11
<b>Code Generation Enhancements . . . . .</b>	<b>13-11</b>
Redundant Condition Checks . . . . .	13-11
Loop Fusion . . . . .	13-12
Invariant Condition Check Lifting . . . . .	13-12
Parameter Pooling for Stateflow and Interpreted MATLAB Function Blocks . . . . .	13-12
Readability Improvement for Reusable Subsystem Input and Output . . . . .	13-12
<b>Enhanced Code Generation Optimization Using Minimum     and Maximum Values . . . . .</b>	<b>13-12</b>
<b>New Model Advisor Check for Code Efficiency of Logic     Blocks . . . . .</b>	<b>13-13</b>

<b>Control of Default Case Generation for Switch Statements in Generated Code for Stateflow Charts</b> . . . . .	<b>13-13</b>
<b>Improvement to Build Process for Conflicting Identifiers</b>	<b>13-14</b>
<b>Update to Code Generation Verification Class <code>cgv.Config</code></b>	<b>13-15</b>
<b>License Names Not Yet Updated for Coder Product Restructuring</b> . . . . .	<b>13-15</b>
<b>New and Enhanced Demos</b> . . . . .	<b>13-15</b>
<b>Check bug reports for issues and fixes</b> . . . . .	<b>13-17</b>

## R2011a

<b>Coder Product Restructuring</b> . . . . .	<b>14-2</b>
Product Restructuring Overview . . . . .	<b>14-2</b>
Resources for Upgrading from Real-Time Workshop Embedded Coder . . . . .	<b>14-3</b>
Migration of Embedded MATLAB Coder Features to MATLAB Coder . . . . .	<b>14-4</b>
Migration of Embedded IDE Link and Target Support Package Features to Simulink Coder and Embedded Coder . . . . .	<b>14-4</b>
Interface Changes Related to Product Restructuring . . . . .	<b>14-5</b>
Simulink Graphical User Interface Changes . . . . .	<b>14-5</b>
<b>Data Management Enhancements and Changes</b> . . . . .	<b>14-6</b>
Memory Section Enhancements . . . . .	<b>14-6</b>
No Longer Able to Set <code>RTWInfo</code> or <code>CustomAttributes</code> Property of Simulink Data Objects . . . . .	<b>14-6</b>
Parts of Data Class Infrastructure Not Available . . . . .	<b>14-7</b>
No Longer Generating Pragma for Data Defined with Built-In Storage Class <code>ExportedGlobal</code> , <code>ImportedExtern</code> , or <code>ImportedExternPointer</code> . . . . .	<b>14-8</b>
Simulink. <code>CustomParameter</code> and Simulink. <code>CustomSignal</code> Data Classes To Be Deprecated in a Future Release . . . . .	<b>14-9</b>



<b>AUTOSAR Enhancements</b> .....	<b>14-9</b>
Calibration Parameters .....	14-9
Multiple Runnables from Virtual Subsystems .....	14-9
Support for Code Descriptor Elements .....	14-10
<b>SIL and PIL Enhancements</b> .....	<b>14-11</b>
Code Execution Profiling .....	14-11
PIL Block Parameter Tuning .....	14-11
Top-Model SIL/PIL and PIL Block Parameter Initialization ..	14-11
Model Block Parameter Tuning and Model Initialization ..	14-11
<b>Code Generation Enhancements</b> .....	<b>14-12</b>
Improved Code for Data Store Memory In-place Assignment .....	14-12
Improvements to Target Function Library Replacements ..	14-12
Improved Loop Fusion .....	14-12
Improved Array Indexing .....	14-12
Improvement on Matrix Parameter Pooling .....	14-13
Readability Improvements Involving Data References ....	14-13
<b>Code Generation Verification (CGV) API Updates</b> .....	<b>14-13</b>
Support for Adding Multiple Callback Functions .....	14-13
New Functionality Added to the cgv.CGV Class .....	14-13
<b>MISRA-C Code Generation Objective</b> .....	<b>14-16</b>
<b>New Model Advisor Check for Code Efficiency of Lookup     Table Blocks</b> .....	<b>14-17</b>
<b>Enhanced Code Generation Optimization</b> .....	<b>14-17</b>
<b>Target Function Library Replacement Based on Computation     Method for Reciprocal Sqrt, Sine, and Cosine</b> .....	<b>14-18</b>
<b>Target Function Library Support for abs, min, max, and sign     functions</b> .....	<b>14-18</b>
<b>C++ Encapsulation Allowed for Referenced Models in For     Each Subsystems</b> .....	<b>14-18</b>
<b>Improved Code Generation for Portable Word Sizes</b> .....	<b>14-19</b>
<b>Improved Comments in the Generated Code</b> .....	<b>14-19</b>

<b>Replacement Data Types and Simulation Mode for Referenced Models</b> .....	<b>14-19</b>
<b>Changes for Embedded IDEs and Embedded Targets</b> .....	<b>14-19</b>
Feature Support for Embedded IDEs and Embedded Targets .....	<b>14-20</b>
Execution Profiling during PIL Simulation .....	<b>14-21</b>
Location of Blocks for Embedded Targets .....	<b>14-21</b>
Location of Demos for Embedded IDEs and Embedded Targets .....	<b>14-22</b>
Multicore Deployment with Rate-Based Multithreading ..	<b>14-23</b>
Windows-Based Code Generation and Remote Build On Linux Target (BeagleBoard) .....	<b>14-24</b>
Changes to Frame-Based Processing .....	<b>14-24</b>
New Support for Analog Devices Blackfin BF50x and BF51x Processors .....	<b>14-25</b>
Generate Optimized Fixed-Point Code for ARM Cortex-M3, Cortex-A8, and Cortex-A9 Processors .....	<b>14-26</b>
Support for Versions 5.0.6 and 5.1.6 of Green Hills MULTI .....	<b>14-26</b>
Support for Texas Instruments Delfino C2834x Processors .....	<b>14-26</b>
Ending Support for Altium TASKING in a Future Release .....	<b>14-27</b>
Ending Support for Freescale MPC5xx in a Future Release .....	<b>14-27</b>
Ending Support for Infineon C166 in a Future Release .....	<b>14-27</b>
Removed Methods and Arguments .....	<b>14-27</b>
<b>Changes to ver Function Product Arguments</b> .....	<b>14-27</b>
<b>New and Enhanced Demos</b> .....	<b>14-28</b>
<b>Check bug reports for issues and fixes</b> .....	<b>14-29</b>

# R2017a

**Version: 6.12**

**New Features**

**Bug Fixes**

**Compatibility Considerations**

## Code Generation from MATLAB Code

### SIL and PIL execution improvements for MATLAB Coder

This table lists software-in-the-loop (SIL) and processor-in-the-loop (PIL) execution improvements.

Feature	R2017a	Previous releases
Interface type: Global data	Supported	Not supported
Size: Dynamic variable-size arrays	Supported	Not supported

For more information, see “SIL/PIL Execution Support and Limitations”.

### Verification of PIL target connectivity configuration

The `piltest` function provides additional tests for verifying your custom processor-in-the-loop (PIL) target connectivity configuration. You can specify tests by using the 'Testpoint' argument.

'Testpoint' Value	Description
'verifyPILConfig'	<p>For a given set of input values, the function:</p> <ul style="list-style-type: none"> <li>• Runs a MATLAB® function on your development computer.</li> <li>• Performs PIL executions of generated MATLAB code on your target hardware with <code>config.TargetLang</code> settings 'C' and 'C++'.</li> </ul> <p>The function compares results from the MATLAB function run and the PIL executions. If the function detects differences, it produces an error.</p>

For more information, see “Create PIL Target Connectivity Configuration”.

## **Code Replacement for MATLAB Coder: Create code replacement library entries for target implementations that require data alignment**

As of R2017a, you can take advantage of function implementations that require aligned data to optimize application performance when using MATLAB Coder™.

For more information, see “Data Alignment for Code Replacement”.

## Model Architecture and Design

### AUTOSAR arxml File Import: Flexibly model imported periodic, asynchronous, and initialization runnables

The AUTOSAR arxml importer now supports AUTOSAR modeling styles for which Simulink® modeling support was added in R2016b. For example, you can

- Import periodic and asynchronous runnables in a JMAAB type beta modeling configuration. The modeling style is described in “Add Top-Level Asynchronous Trigger to Periodic Rate-Based System”.
- Import an initialize runnable, which the importer now represents with a Simulink Initialize Function block.

To import an AUTOSAR software component with multiple runnable entities into a Simulink model, you use the arxml importer method `createComponentAsModel`. As part of improved runnable modeling, the `createComponentAsModel` method now provides the property `ModelPeriodicRunnablesAs`, which replaces the property `CreateInternalBehavior`. At model creation time, set `ModelPeriodicRunnablesAs` to one of these values:

- `AtomicSubsystem` (default) — Import AUTOSAR periodic runnables found in arxml files. Model periodic runnables as atomic subsystems with periodic rates in a rate-based model. If conditions prevent use of atomic subsystems, the importer throws an error.
- `FunctionCallSubsystem` — Model periodic runnables as function-call subsystems with periodic rates.
- `Auto` — Attempt to model periodic runnables as atomic subsystems. If conditions prevent use of atomic subsystems, model periodic runnables as function-call subsystems.

Set `ModelPeriodicRunnablesAs` to `AtomicSubsystem` unless your design requires use of function-call subsystems. The following call directs the importer to import a multirunnable AUTOSAR software component and map it into a new rate-based model.

```
obj = arxml.importer('mySWC.arxml')
createComponentAsModel(obj, '/pkg/swc/ASWC', 'ModelPeriodicRunnablesAs', 'AtomicSubsystem')
```

For more information, see “Import AUTOSAR Software Component” and “Model AUTOSAR Software Components”.

## AUTOSAR DESC elements populate Simulink Description fields

Importing AUTOSAR DESC information associated with an AUTOSAR identifiable element now populates the **Description** property in the corresponding Simulink element or data object. Correspondingly, exporting a Simulink element or data object **Description** property now populates the DESC information in the corresponding AUTOSAR element. Previously, Embedded Coder® preserved AUTOSAR DESC information across arXML round-trips but did not leverage the information to add a readable text description to the Simulink model.

For example, suppose that you open the example model `rtwdemo_autosar_swc_slfcns` and add a description to the Simulink Function block `read_data`. Use the block properties dialog.

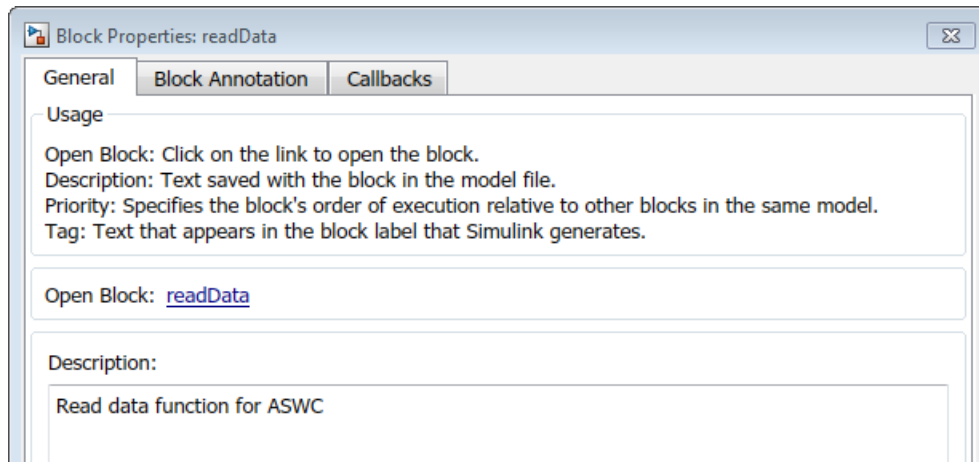

When you export `arxml` for the model, the generated runnable description contains the Simulink description text.

```
<RUNNABLE-ENTITY UUID="...">
  <SHORT-NAME>Runnable_readData</SHORT-NAME>
  <DESC>
    <L-2 L="FOR-ALL">Read data function for ASWC</L-2>
  </DESC>
  ...
  <SYMBOL>readData</SYMBOL>
</RUNNABLE-ENTITY>
```

---

**Note:** This support is available to R2015b, R2016a, and R2016b Embedded Coder customers by installing the latest AUTOSAR support package for your release:

- R2015b Embedded Coder Support Package for AUTOSAR Standard, Version 15.2.8 or later
  - R2016a Embedded Coder Support Package for AUTOSAR Standard, Version 16.1.5 or later
  - R2016b Embedded Coder Support Package for AUTOSAR Standard, Version 16.2.2 or later
- 

## External mode code generation for a model containing inline variant blocks

In R2017a, for a model containing Variant Source or Variant Sink blocks, you can generate code for the external mode data interface. In the block parameters dialog box, clear the **Analyze all choices during update diagram and generate preprocessor conditionals** parameter. For more information on external mode, see “Set Up and Use Host/Target Communication Channel”.

## Code generation support for Variant Subsystems containing global signals

In R2017a, you can generate code for a model containing a Variant Subsystem with global signals inside it. You declare signals as global by assigning them a storage class other than Auto. See “Storage Classes for Signals Used with Model Blocks”.

## Preprocessor conditionals guard content inside and outside of function-call site

In R2016b, for a model that contained a conditional function-call subsystem, preprocessor conditionals guarded only the content inside the function. In R2017a, preprocessor conditionals guard the content and the function-call site.

For example, in the model `func_call_guards`, a Variant Source block connects to the function-call subsystem `Proc_Ini`.



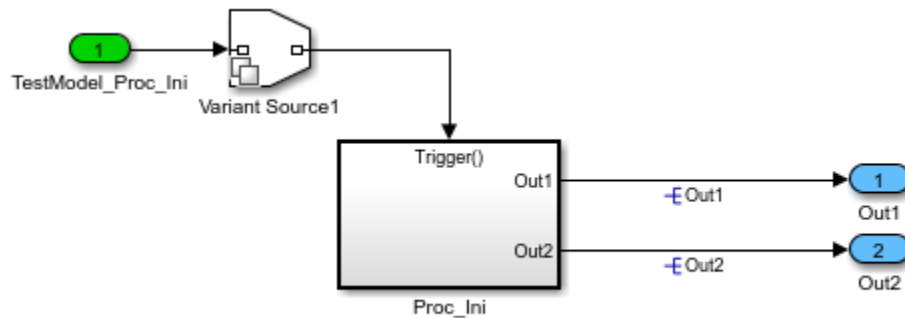

In R2016b, the code generator produced this code:

```

/* Model step function */
void TestModel_Proc_Ini(void)
{
    /* RootInportFunctionCallGenerator: '<Root>
    /RootFcnCall_InsertedFor_TestModel_Proc_Ini_at_outport_1' */
    #if W == 1

        /* Outputs for Function Call SubSystem: '<Root>/Proc_Ini' */
        /* SignalConversion: '<S1>/OutportBufferForOut1' */
        Out1 = 1.0F;

        /* SignalConversion: '<S1>/OutportBufferForOut2' */
        Out2 = 1.0F;

        /* End of Outputs for SubSystem: '<Root>/Proc_Ini' */
    #endif
        /* W == 1 */

        /* End of Outputs for RootInportFunctionCallGenerator: '<Root>
        /RootFcnCall_InsertedFor_TestModel_Proc_Ini_at_outport_1' */
    }

```

The preprocessor conditionals guarded the content inside the function Proc\_Ini.

In R2017a, the code generator produces this code:

```

/* Model step function */
#if W == 1

```

```
void TestModel_Proc_Ini(void)
{
    /* RootInportFunctionCallGenerator: '<Root>'
    /RootFcnCall_InsertedFor_TestModel_Proc_Ini_at_output_1' */
    #if W == 1

        /* Outputs for Function Call SubSystem: '<Root>/Proc_Ini' */
        /* SignalConversion: '<S2>/OutputBufferForOut1' */
        Out1 = 1.0F;

        /* SignalConversion: '<S2>/OutputBufferForOut2' */
        Out2 = 1.0F;

        /* End of Outputs for SubSystem: '<Root>/Proc_Ini' */
    #endif
        /* W == 1 */

        /* End of Outputs for RootInportFunctionCallGenerator: '<Root>'
        /RootFcnCall_InsertedFor_TestModel_Proc_Ini_at_output_1' */
    }
}

#endif
/* W == 1 */
```

The preprocessor conditionals guard the content inside and outside of the function Proc\_Ini.

## Data, Function, and File Definition

### Function Interface: Return nonvoid type for scalar output of reusable functions

In R2016b, reusable functions had a return type of `void`. In R2017a, reusable functions can return a nonvoid type. The code generator can return a nonvoid type if the reusable function has one output parameter that is a scalar and in the Configuration Parameters dialog box, on the **Optimization > Signals and Parameters** pane, the **Pass reusable subsystem outputs as** parameter is set to `Individual arguments`.

Returning a nonvoid type conserves RAM consumption because the generated code does not contain a global variable to hold the output parameter value. There are also minor improvements in ROM consumption because the function call site and the function body are smaller.

For example, the model `reusable_sub` contains four reusable subsystems. `Subsystem2` contains `Subsystem3`. `Subsystem1`, `Subsystem3`, and `Subsystem4` contain the blocks shown in this diagram following the model. The subsystem output is a scalar.

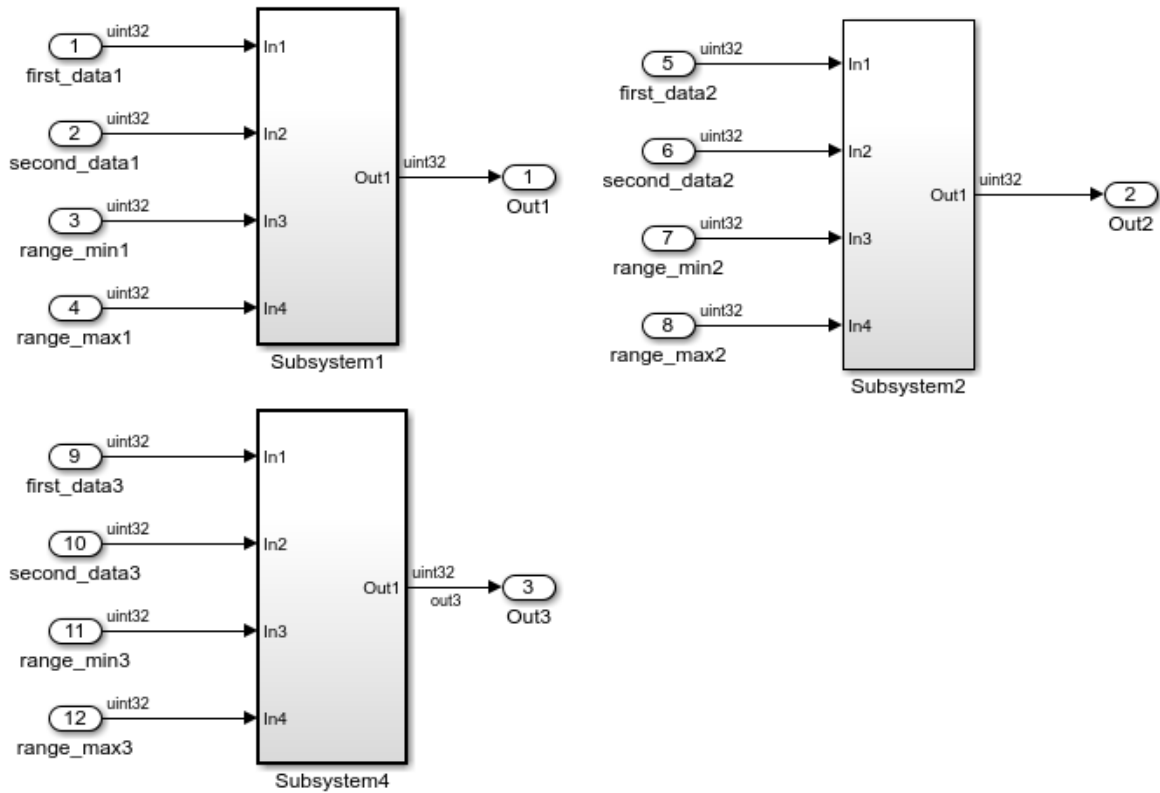

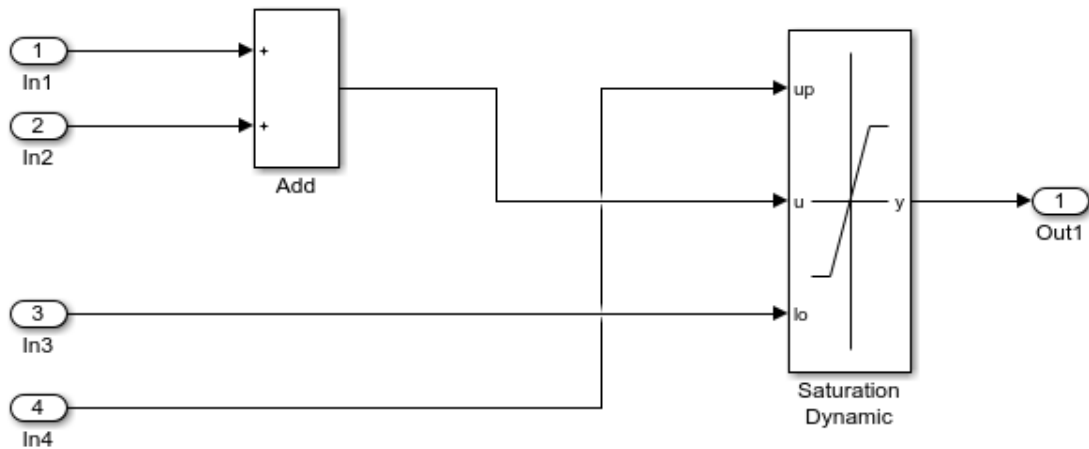

In R2016b, the reusable subsystem function contained this code:

```
void reusable_sub_Subsystem1(uint32_T rtu_In1, uint32_T rtu_In2, uint32_T
    rtu_In3, uint32_T rtu_In4, uint32_T *rty_Out1)
```

```
{
    uint32_T rtb_Add;
    rtb_Add = rtu_In1 + rtu_In2;
    if (rtb_Add > rtu_In4) {
        *rty_Out1 = rtu_In4;
    } else if (rtb_Add < rtu_In3) {
        *rty_Out1 = rtu_In3;
    } else {
        *rty_Out1 = rtb_Add;
    }
}
```

```
void reusable_sub_step(RT_MODEL_reusable_sub *const reusable_sub_M,
    ExternalInputs_reusable_sub *reusable_sub_U, ExternalOutputs_reusable_sub
    *reusable_sub_Y)
```

```
{
    reusable_sub_Subsystem1(reusable_sub_U->first_data1,
        reusable_sub_U->second_data1, reusable_sub_U->range_min1,
        reusable_sub_U->range_max1, &reusable_sub_Y->Out1);
    reusable_sub_Subsystem1(reusable_sub_U->first_data2,
        reusable_sub_U->second_data2, reusable_sub_U->range_min2,
        reusable_sub_U->range_max2, &reusable_sub_Y->Out2);
}
```

```
    reusable_sub_Subsystem1(reusable_sub_U->first_data3,
        reusable_sub_U->second_data3, reusable_sub_U->range_min3,
        reusable_sub_U->range_max3, &reusable_sub_Y->Out3);
    UNUSED_PARAMETER(reusable_sub_M);
}
```

In R2016b, the generated code contained the global variable `rty_Out1` to hold the output. `rty_Out1` was passed to `reusable_sub_Subsystem1`.

In R2017a, the `reusable_sub.c` file contains this code:

```
uint32_T reusable_sub_Subsystem1(uint32_T rtu_In1, uint32_T rtu_In2, uint32_T
    rtu_In3, uint32_T rtu_In4)
{
    uint32_T rty_Out1_0;
    rty_Out1_0 = rtu_In1 + rtu_In2;
    if (rty_Out1_0 > rtu_In4) {
        rty_Out1_0 = rtu_In4;
    } else {
        if (rty_Out1_0 < rtu_In3) {
            rty_Out1_0 = rtu_In3;
        }
    }
}

return rty_Out1_0;
}

void reusable_sub_step(RT_MODEL_reusable_sub *const reusable_sub_M,
    ExternalInputs_reusable_sub *reusable_sub_U, ExternalOutputs_reusable_sub
    *reusable_sub_Y)
{
    reusable_sub_Y->Out1 = (uint32_T) reusable_sub_Subsystem1
        (reusable_sub_U->first_data1, reusable_sub_U->second_data1,
        reusable_sub_U->range_min1, reusable_sub_U->range_max1);
    reusable_sub_Y->Out2 = (uint32_T) reusable_sub_Subsystem1
        (reusable_sub_U->first_data2, reusable_sub_U->second_data2,
        reusable_sub_U->range_min2, reusable_sub_U->range_max2);
    reusable_sub_Y->Out3 = (uint32_T) reusable_sub_Subsystem1
        (reusable_sub_U->first_data3, reusable_sub_U->second_data3,
        reusable_sub_U->range_min3, reusable_sub_U->range_max3);
    UNUSED_PARAMETER(reusable_sub_M);
}
```

The generated code does not contain a global variable to hold output. Instead, the function returns the local variable `rty_Out1_0`.

## **Utility to generate Simulink representations of struct and enum types defined by external C code**

Before R2017a, to generate code that used `struct` and `enum` types defined by your external code, you had to manually create the corresponding definitions in Simulink (for example, `Simulink.Bus` objects).

In R2017a, you can generate these corresponding Simulink definitions by using a programmatic utility. The utility parses your external C code for `struct` and `enum` type definitions. For more information, see “Utility to generate Simulink representations of custom data types defined by external C code” (Simulink).

## Code Generation

### Cross-Release Code Integration: Reuse model reference code generated from previous releases

In R2017a, you can integrate exported component code that uses the model reference code interface. Previously, the cross-release integration workflow supported only component code that used the standalone code interface. For more information, see “Cross-Release Code Integration”.

### Compatibility Considerations

For the `crossReleaseImport` function, the value for the `CodeLocation` argument specifies the path to an anchor folder that contains the relocated model code folder. Previously, the `CodeLocation` value specified the path to the relocated model code folder.

For R2017a, if you relocate generated model code, use an anchor folder and maintain the original code folder names and structure.

Model Component	Code Interface	Original Code Location	New Code Location
Top model	Standalone	<code>codegenFolder/modelName_ert_rtw</code>	<code>anchorFolder/modelName_ert_rtw</code>
Reference model	Model reference	<code>codegenFolder/slprj/ert/refmodelName</code>	<code>anchorFolder/slprj/ert/refmodelName</code>
Subsystem	Standalone	<code>codegenFolder/subSysName_ert_rtw</code>	<code>anchorFolder/subSysName_ert_rtw</code>

### Code Replacement for Cast and Multiply Operations: Detect overflow and rounding mode equivalence for increased matches and code efficiency

As of R2017a, the code replacement software support for detecting overflow and rounding mode equivalence is enhanced for cast operations and multiply operations:

- Cast operations — When an operation does not overflow, based on input and output data types, a match occurs for code replacement table entries with the saturation mode set to **Wrap on Overflow** (`RTW_WRAP_ON_OVERFLOW`). Similarly, if the code replacement software detects equivalent rounding modes, a match occurs.



- **Multiplication operations** — The detection of overflow and rounding modes equivalence is enhanced to support a mixture of fixed-point and floating-point types.

For more information, see “Develop a Code Replacement Library”.

## More information in code generation report summary

Additional fields in the code generation report **Summary** page provide information on your model and the generated code, including:

- **Author**
- **Last Modified By**
- **Tasking Mode** (except for exported models)
- **System Target File**
- **Hardware Device Type**
- **Type of Build**
- **Memory Information** (if you select parameter **Code Generation > Report > Static code metrics**)
- **Code Generation Advisor** (if you run Code Generation Advisor as part of the build process, it provides link to **Code Generation Advisor Report**)
- **Code Reuse Exception** (if exceptions exist, it links to **Subsystem Report**)

For more information on code generation reports, see “Reports for Code Generation”.

## Code Interface Report: Includes entry-point function for code generated from Reset Function block

Starting in R2017a, the Code Interface Report section of the Code Generation Report includes entry-point function information for code generated from Reset Function blocks. For more information, see “Generate Code That Responds to Initialize, Reset, and Terminate Events” and “Analyze the Generated Code Interface”.

## Shared utility memory section associated with subfunctions

Previously, you could not predict which memory section was associated with subfunctions in the generated code. Simulink Coder generates these subfunctions for intrinsic math

utilities, Stateflow<sup>®</sup> graphical functions, and MATLAB subfunctions. The possible associations included:

- The **Shared utility** memory section that you specify at the model level.
- The **Execution** memory section that you specify at the model level.
- The **Execution** memory section that you specify for one of the subsystems.

In R2017a, the memory section associated with these subfunctions is always the **Shared utility** memory section that you specify at the model level.

## Inline traceability for generated code

Model-to-code and code-to-model navigation are enhanced for Embedded Coder in R2017a. Inline traceability is now fully supported:

- For MATLAB functions
- For Simulink blocks, with the exception of From Workspace and From File blocks

For more information on bidirectional traceability, see “What Is Code Tracing?”.

## Clear file section content from TLC file

The ability to reset a file section buffer in TLC was removed in R2015a. In R2017a, you can use the TLC function `LibClearFileSectionContents` to clear a file section buffer so that you can reset it. This function can be applied to the following sections:

- Banner
- Includes
- ModelTypesTypedefs
- Defines
- ModelTypesDefines
- IntrinsicTypes
- PrimitiveTypedefs
- UserTop
- Typedefs
- Enums

- Definitions
- ExternData
- ExternFcns
- FcnPrototypes
- Declarations
- Functions
- CompilerErrors
- CompilerWarnings
- Documentation
- UserBottom

## Identifier case control with token decorators and custom text token \$U

### \$U Token for Specifying Text in Generated Identifiers

On the **Code Generation > Symbols** pane, you can use the \$U token to specify text to include in the generated identifiers. All the identifiers on the **Symbols** pane accept this new token.

You set the value of \$U by specifying a character vector for the **Custom token text** parameter. The **Custom token text** parameter is on the **All Parameters** tab in the Configuration Parameters dialog box.

For more information, see “Identifier Format Control” and “Custom token text”.

### Case Control with Token Decorators

On the **Code Generation > Symbols** pane, you can use new token decorators to control the case of generated identifiers. For example, use this technique to apply camel case style.

Place a decorator immediately after a token and enclose the decorator in square brackets [ ]. For example, you can set **Global variables** to \$R[uL]\$N\$M, which capitalizes the first letter of the model name and forces the remaining characters in the model name to lowercase.

For more information, see “Control Case with Token Decorators”.

## **Name change for AUTOSAR local temporary variables**

Previously, for an AUTOSAR model, the name for local temporary variables in the generated code was `tmp`. In R2017a, the name is `tmp` plus an identifier associated with the data access mode of the variable, such as `IRead` or `IWrite`. For example, in R2017a, the name of a local temporary variable with an `ImplicitReceive` data access mode is `tmpIRead`.

## **Additional checks against MISRA C:2012 guidelines in Code Generation Advisor**

In R2017a, when the Code Generation Advisor checks your model against the MISRA C:2012 guidelines objective, it executes these additional checks:

- “Check for blocks not recommended for C/C++ production code deployment”
- “Check for unsupported block names”
- “Check usage of Assignment blocks”
- “Check for bitwise operations on signed integers”
- “Check for recursive function calls”
- “Check for equality and inequality operations on floating-point values”
- “Check for switch case expressions without a default case”

Also for the MISRA C:2012 guidelines objective, the Code Generation Advisor considers these additional parameters:

- “Shared code placement” (Simulink Coder) (`UtilityFuncGeneration`)
- “System-generated identifiers” (Simulink Coder) (`InternalIdentifier`)
- “Use dynamic memory allocation for model initialization” (Simulink Coder) (`GenerateAllocFcn`)

## Deployment

### **TI Code Composer Studio (CCS): Generate projects for CCS versions 5 and 6 with Embedded Coder Target for TI C2000**

When you build Simulink models for TI C2000 targets with CCS v5 or v6 toolchains, the Code Composer Studio project is also generated. You can use this project for debugging the generated code.

### **Customize generated makefiles for S-Functions**

To customize generated makefiles for S-functions, create `makecfg.m` and `yourSFunction_makecfg.m` files that use `RTW.BuildInfo` functions to specify:

- Additional source files and libraries
- Preprocessor macro definitions
- Compiler flags

For more information, see:

- “Use `makecfg` to Customize Generated Makefiles for S-Functions”
- “Import Calls to External Code into Generated Code with Legacy Code Tool”

### **Release notes and workflow overview documentation added to AUTOSAR support package**

R2017a adds release notes and workflow overview documentation to the Embedded Coder Support Package for AUTOSAR Standard. The release notes describe AUTOSAR support changes from the current release back through R2014b. Other help topics provide an overview of AUTOSAR workflows, with links to the main “AUTOSAR” help.

After you install the support package, restart MATLAB, open help (for example, with the `MATLAB doc` command), and go to the Hardware Support section. To access release notes and other help topics, click the link “Embedded Coder Support Package for AUTOSAR Standard”.

### **SPI and I2C blocks added to TI C2000 support package**

This table lists the support for the new blocks.

Block	Usage
SPI Receive	Receive data via serial peripheral interface (SPI) on target.
SPI Transmit	Transmit data via serial peripheral interface (SPI) to host.
I2C Receive	Configure inter-integrated circuit (I2C) module to receive data from I2C bus.
I2C Transmit	Configure inter-integrated circuit (I2C) module to transmit data to I2C bus.

## CCS v3.3 IDE automation support for TI C2000 has been removed

The support for TI C2000 with `idmlink_ert.tlc` as system target file has been removed. You can still use the TI C2000 support by using the `ert.tlc` as the system target file.

## Real-time multitasking profiling for TI C2000

You can use real-time execution profiling to verify whether generated code meets the real-time performance requirements.

## TCP and UDP blocks added to STMicroelectronics STM32F746G-Discovery board

This table lists the support for these new blocks.

Block	Usage
TCP Receive	Receive TCP packets from another TCP host on TCP/IP network
TCP Send	Send TCP packets to another TCP host on TCP/IP network
UDP Receive	Receive UDP packets from another UDP host
UDP Send	Send UDP packets to another UDP host

## MATLAB Coder PIL with STMicroelectronics STM32F4-Discovery Board

In R2017a, you can use processor-in-the-loop (PIL) executions to verify generated code that you deploy to target hardware using a MATLAB Coder workflow with an Embedded Coder license. By using PIL with hardware, you can generate customized code for your hardware more effectively by profiling speed and algorithm performance. You have the option of using the command-line workflow or the MATLAB Coder app to configure your target hardware for PIL executions.

To use this feature, you must have MATLAB Coder and the support package installed.

This example shows how to use a PIL execution to verify generated code.

- 1 In the command window, select the hardware for PIL execution.

```
hw = coder.hardware('STM32F4-Discovery');
```

- 2 Add the hardware to the MATLAB Coder configuration object.

```
cfg = coder.config('lib', 'ecoder', true);  
cfg.VerificationMode = 'PIL';  
cfg.Hardware = hw;
```

- 3 As the stack space in the target hardware is limited, set the maximum stack space that the generated code uses.

```
cfg.StackUsageMax = 512;
```

- 4 Generate PIL code for a function, computeFFT.

```
codegen -config cfg computeFFT -args {inp}
```

Here, `computeFFT` is a user-defined function. The `inp` parameter declares the data type and size for input arguments to MATLAB function `computeFFT`.

The `codegen` command generates code into following folders:

- `codegen\lib\computeFFT`: Standalone code for `computeFFT`.
- `codegen\lib\computeFFT\pil`: PIL interface code for `computeFFT`.

Also, this step creates `computeFFT_pil` PIL MEX function in the current folder. This function allows you to test the MATLAB code and the PIL MEX function and compare the results between both.

- 5 Run the PIL MEX function to compare its behavior to that of the original MATLAB function and to check for defects.

```
u1 = uint16(zeros(1,16));  
y = computeFFT_pil(u1);
```

Terminate PIL execution with the following command.

```
clear computeFFT_pil;
```

Using the MATLAB Coder app workflow:

- 1 Configure the build type and hardware board. On the **Generate Code** page, in the **Generate** dialog box:
  - Set the **Build Type** to **Static Library**.
  - Clear the **Generate code only** check box.
  - Set the **Hardware Board** to **STM32F4-Discovery**.
- 2 You can modify the settings for your board. To modify the settings, click **Settings > All Settings**.

Specify the maximum stack space required by the generated code in the **Memory > Stack usage max** parameter. The stack space in the target hardware is limited, and a default value of 20000 is beyond the stack size available in the target hardware. A value of 512 is recommended. You can specify the stack size based on the requirement of your application.

- 3 Click **Hardware**.
- 4 To generate the library, click **Generate**.
- 5 Set up for PIL execution. Click **Verify Code** to open the **Verify Code** dialog box.

Because the hardware board is not **MATLAB Host Computer**, the **Verify Code** dialog box is configured for PIL execution.

In the **Verify Code** dialog box:

- Enter the name of the test file to use for PIL execution.
  - Select **Generated code**.
- 6 To start the PIL execution, click **Run Generated Code**.
  - 7 To stop the PIL execution, click **Stop**.

For more information, on how to compile your code using the MATLAB Coder app, see “Opening the MATLAB Coder App” (MATLAB Coder).



For more information, on how to use the Embedded Coder Support Package for STMicroelectronics® Discovery Boards for Processor-in-the-Loop (PIL) verification of MATLAB functions, see “Processor-in-the-Loop Verification of MATLAB Functions” (Embedded Coder Support Package for STMicroelectronics Discovery Boards).

## **External Mode and PIL supported over TCP/IP by STMicroelectronics STM32F746G-Discovery board**

The STMicroelectronics STM32F746G-Discovery™ board supports PIL and external mode over TCP/IP.

Install the Embedded Coder Support Package for STMicroelectronics Discovery Boards to use this support.

To install or update this support package, perform the steps described in “Install Support for STMicroelectronics Discovery Boards” (Embedded Coder Support Package for STMicroelectronics Discovery Boards).

For more information, see “Embedded Coder Support Package for STMicroelectronics Discovery Boards”.

## **Linux Support: Connect to ARM Cortex-M processor on Linux platform**

You can use the Embedded Coder Support Package for ARM® Cortex®-M Processors on the Linux host platform to generate and build ARM Cortex-M optimized code from models.

---

**Note:** You cannot load and run code generated from a model on the Linux host platform using ARM Cortex-M QEMU emulator.

---

## **ARM Cortex-R optimized code**

Use the Embedded Coder Support Package for ARM Cortex-R Processors to build optimized executables with automatic code replacement from the Hercules™ Safety MCU Cortex™-R4 CMSIS DSP Library.

## **Develop a Target for ARM Cortex-R processors**

The Embedded Coder Support Package for ARM Cortex-R Processors supports the development of user specified Targets. Targets include deployment, scheduling, processor-in-the-loop, external mode, code replacement, and profiler features.

## **Support for Wind River VxWorks RTOS will be removed**

Embedded Coder support for Wind River VxWorks RTOS will be removed in a future release. You will still be able to use Embedded Coder for Wind River<sup>®</sup> VxWorks RTOS, but will need to manually integrate the generated code with hand written scheduler and drivers.

## Performance

### Data Copy Reduction: Generate fewer data copies and use less RAM for buses, data stores, and model blocks

In R2017a, the generated code contains less temporary variables and associated data copies for modeling patterns involving Bus Assignment, Data Store Read, Data Store Write, and Model blocks. These optimizations conserve RAM usage and improve code execution speed. The following examples highlight these improvements:

- “Data copy reduction for Bus Assignment block” on page 1-25
- “Data copy reduction for Data Store Read and Data Store Write blocks” on page 1-27
- “More efficient code for Model blocks” on page 1-30

#### Data copy reduction for Bus Assignment block

Previously, for a model that contained a Bus Assignment block, there was an extra temporary variable and associated data copy in the generated code. In R2017a, the code generator can remove this data copy. This optimization increases code execution speed and conserves RAM consumption.

For example, in `bus_assignoptim`, a bus signal containing six elements feeds into a Bus Assignment block and a Bus Selector block. The Bus Assignment block assigns new values to the bus element `a1_real_array`. This bus signal feeds into `Out1`.

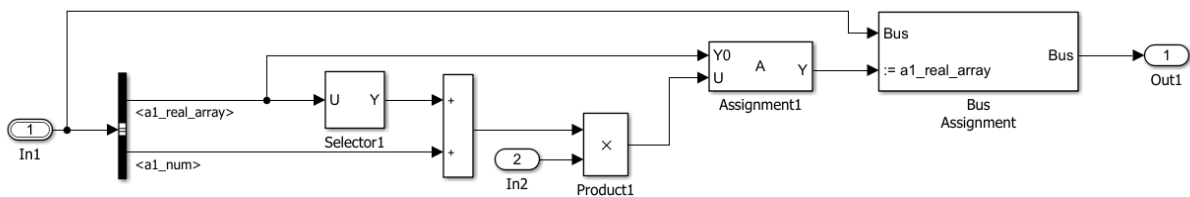

In R2016b, the code generator produced this code in the `bus_assignoptim_step` function:

```
/* Model step function */
void bus_assignoptim_step(void)
{
    real_T rtb_Assignment[36];
```

```
int32_T i;

/* Assignment: '<Root>/Assignment' incorporates:
 * Inport: '<Root>/In1'
 * Inport: '<Root>/In2'
 * Product: '<Root>/Product'
 * Selector: '<Root>/Selector'
 * Sum: '<Root>/Sum1'
 */
for (i = 0; i < 36; i++) {
    rtb_Assignment[i] = bus_assignoptim_U.In1.a1_real_array[i];
}

for (i = 0; i < 2; i++) {
    rtb_Assignment[(int32_T)(i + 22)] = (bus_assignoptim_U.In1.a1_real_array
    [(int32_T)(i + 22)] + bus_assignoptim_U.In1.a1_num) *
    bus_assignoptim_U.In2;
}

/* End of Assignment: '<Root>/Assignment' */

/* BusAssignment: '<Root>/Bus Assignment' incorporates:
 * Inport: '<Root>/In1'
 */
bus_assignoptim_Y.Out = bus_assignoptim_U.In1;
for (i = 0; i < 36; i++) {
    bus_assignoptim_Y.Out.a1_real_array[i] = rtb_Assignment[i];
}

/* End of BusAssignment: '<Root>/Bus Assignment' */
}
```

The generated code contains the temporary array `rtb_Assignment1` for holding data before this data is assigned to `bus_assignoptim_Y.Out2.dbl_real_array`.

In R2017a, the `bus_assignoptim_step` function contains this code:

```
/* Model step function */
void bus_assignoptim_step(void)
{
    int32_T i;

    /* SignalConversion: '<Root>/TmpBusAssignmentBufferAtBus...'
     * Inport: '<Root>/In1'
     */
}
```

```

bus_assignoptim_Y.Out = bus_assignoptim_U.In1;

/* Assignment: '<Root>/Assignment' incorporates:
 * Inport: '<Root>/In1'
 * Inport: '<Root>/In2'
 * Product: '<Root>/Product'
 * Selector: '<Root>/Selector'
 * Sum: '<Root>/Sum1'
 */
for (i = 0; i < 36; i++) {
    bus_assignoptim_Y.Out.a1_real_array[i] =
        bus_assignoptim_U.In1.a1_real_array[i];
}

for (i = 0; i < 2; i++) {
    bus_assignoptim_Y.Out.a1_real_array[(int32_T)(i + 22)] =
        (bus_assignoptim_U.In1.a1_real_array[(int32_T)(i + 22)] +
         bus_assignoptim_U.In1.a1_num) * bus_assignoptim_U.In2;
}

/* End of Assignment: '<Root>/Assignment' */
}

```

The generated code does not contain the temporary array `rtb_Assignment1` for holding data. The generated code directly assigns the data to `bus_assignoptim_Y.Out2.dbl_real_array`.

---

**Note:** You can disable this optimization by deselecting the **Perform inplace updates for Bus Assignment blocks** parameter. In the Configuration Parameters dialog box, this parameter is on the **All Parameters** tab.

---

### Data copy reduction for Data Store Read and Data Store Write blocks

In R2016b, the generated code contained an extra buffer when reading from a Data Store Read block or when writing to a Data Store Write block. In R2017a, the code generator can eliminate this extra data copy. This optimization conserves RAM consumption and improves code execution speed.

For example, in the model `rtwdemo_optimizedatastorebuffers`, the Function caller `UpdateFunc` calls the Simulink Function `DefineUpdateFunc`. The Data Store Read block `DSR` reads from `mem`. The Data Store Write block `DSW` writes to `mem`.

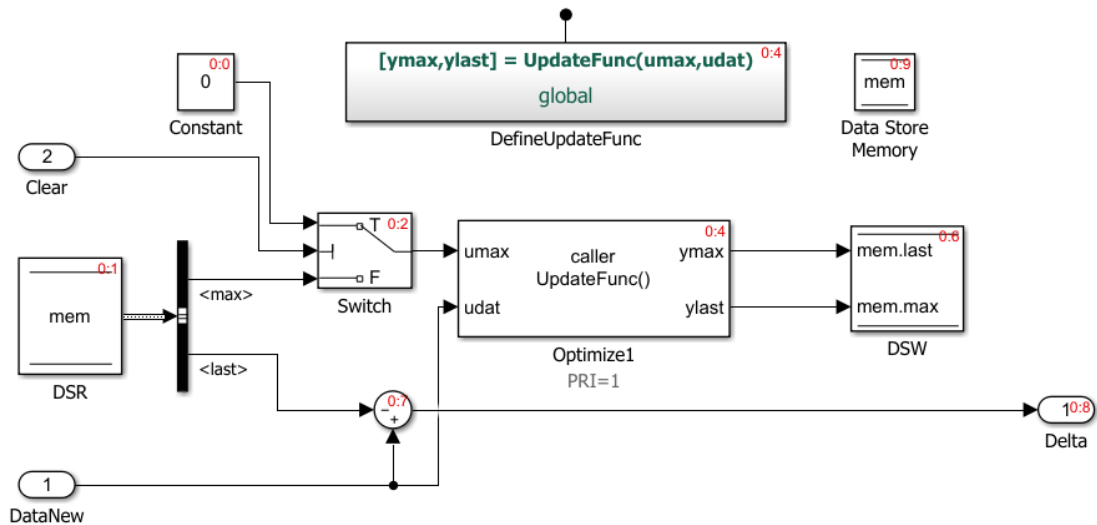

In R2016b, the code generator produced this code:

```

/* Model step function */
void rtwdemo_optimizedatastorebuffers_step(void)
{
    real_T rtb_DSR_last;
    real_T rtb_Optimize1_o1;
    real_T rtb_Optimize1_o2;

    /* DataStoreRead: '<Root>/DSR' */
    rtb_DSR_last = mem.last;

    /* Switch: '<Root>/Switch' incorporates:
     * Constant: '<Root>/Constant'
     * DataStoreRead: '<Root>/DSR'
     * Inport: '<Root>/Clear'
     */
    if (rtU.Clear) {
        rtb_Optimize1_o1 = 0.0;
    } else {
        rtb_Optimize1_o1 = mem.max;
    }
}

```

```

/* End of Switch: '<Root>/Switch' */

/* FunctionCaller: '<Root>/Optimize1' incorporates:
 * Inport: '<Root>/DataNew'
 */
UpdateFunc(rtb_Optimize1_o1, rtU.DataNew, &rtb_Optimize1_o1, &rtb_Optimize1_o2);

/* DataStoreWrite: '<Root>/DSW' */
mem.last = rtb_Optimize1_o1;
mem.max = rtb_Optimize1_o2;

/* Outport: '<Root>/Delta' incorporates:
 * Inport: '<Root>/DataNew'
 * Sum: '<Root>/Sum'
 */
rtY.Delta = rtU.DataNew - rtb_DSR_last;
}

```

The generated code contained data copies for the Data Store Read and Data Store Write blocks, respectively.

In R2017a, the code generator produces this code:

```

/* Model step function */
void rtwdemo_optimizedatastorebuffers_step(void)
{
    real_T rtb_DSR_last;
    real_T tmp;

    /* DataStoreRead: '<Root>/DSR' */
    rtb_DSR_last = mem.last;

    /* Switch: '<Root>/Switch' incorporates:
     * Constant: '<Root>/Constant'
     * DataStoreRead: '<Root>/DSR'
     * Inport: '<Root>/Clear'
     */
    if (rtU.Clear) {
        tmp = 0.0;
    } else {
        tmp = mem.max;
    }

    /* End of Switch: '<Root>/Switch' */
}

```

```
/* FunctionCaller: '<Root>/Optimize1' incorporates:  
 * Inport: '<Root>/DataNew'  
 */  
UpdateFunc(tmp, rtU.DataNew, mem.last, mem.max);  
  
/* Outport: '<Root>/Delta' incorporates:  
 * Inport: '<Root>/DataNew'  
 * Sum: '<Root>/Sum'  
 */  
rtY.Delta = rtU.DataNew - rtb_DSR_last;  
}
```

The data copy for the Data Store Write block is not in the generated code. The code contains the data copy for the Data Store Read block because the Sum block executes after the Data Store Write block. The generated code contains the variable `rtb_DSR_last` to hold the output of the Sum block. Therefore, the Sum block gets the values that `Optimize1` calculates at the start of the time step rather than those values at the next time step. If the priority of the Sum block is lower than `Optimize1`, the code generator can remove the data copy for the Data Store Read block.

Some other cases in which the code generator might not eliminate data copies are:

- A Simulink Function internally writes to the Data Store Memory block.
- The Data Store Read or Data Store Write blocks select elements of an array from the Data Store Memory block.
- The Data Store Memory block has a custom storage class.
- The Data Store Read and Data Store Write blocks occur on the same block unless that block is a Bus Assignment block or an Assignment block.

---

**Note:** You can disable this optimization by setting the **Reuse buffers for Data Store Read and Data Store Write blocks** parameter to **off**. In the Configuration Parameters dialog box, this parameter is on the **All Parameters** tab.

---

### More efficient code for Model blocks

In R2017a, the generated code contains additional optimizations for modeling patterns involving Model blocks. These optimizations include turning global variables into local variables, buffer elimination, data copy reduction, and expression folding. The optimizations improve ROM and RAM consumption and increase code execution speed.



For example, the model `model_ref` contains the Model block `SimSubE`.

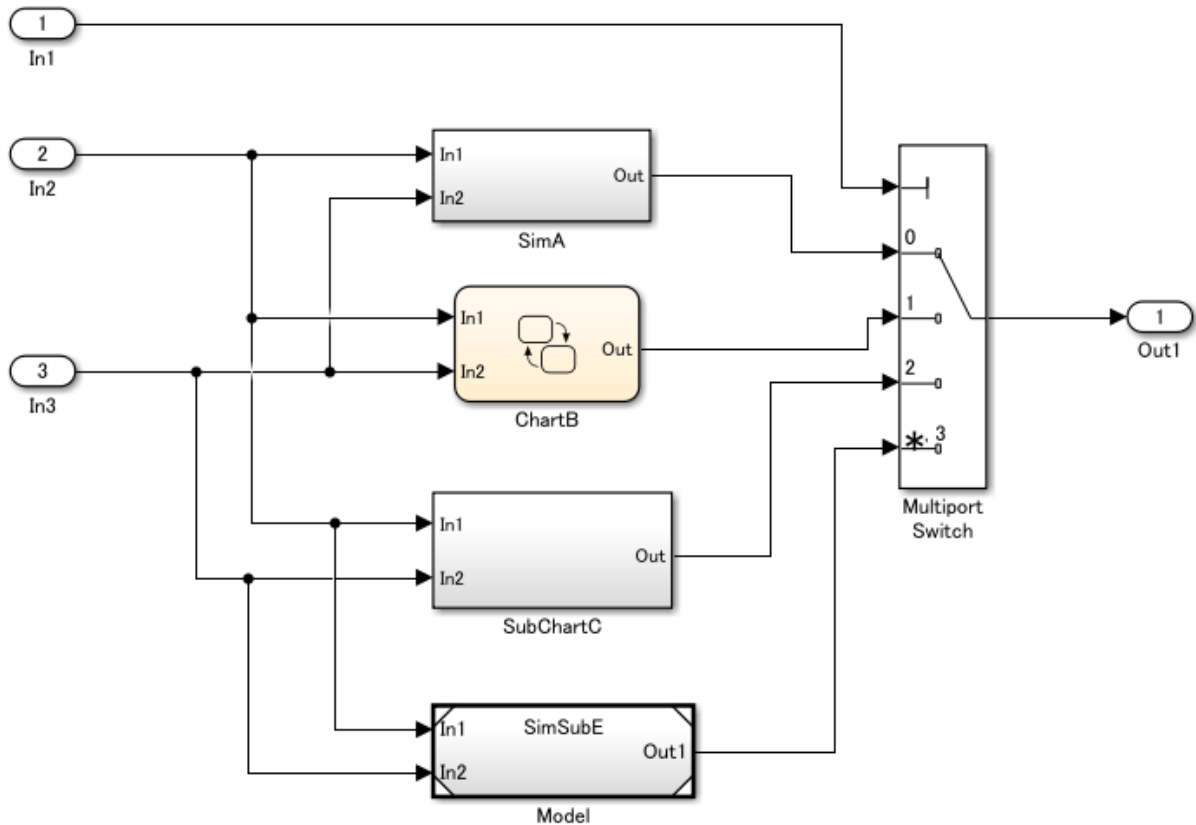

In R2016b, the code generator produced this code:

```

/* Model step function */
void model_ref_step(void)
{
    /* local block i/o variables */
    uint16_T u16_Model;
    uint16_T u16_Out_m;
    uint16_T u16_Out;
    if (model_ref_U.In3 > 30U) {
        u16_Out_m = model_ref_U.In2 + /*MW:0vSat0k*/ 5U;
        if (u16_Out_m < model_ref_U.In2) {

```

```
        u16_Out_m = MAX_uint16_T;
    }
} else {
    u16_Out_m = model_ref_U.In2 + /*MW:OvSatOk*/ 12U;
    if (u16_Out_m < model_ref_U.In2) {
        u16_Out_m = MAX_uint16_T;
    }
}

if (model_ref_U.In2 > 20U) {
    u16_Out = model_ref_U.In2 + model_ref_U.In3;
} else {
    u16_Out = model_ref_U.In2 + /*MW:OvSatOk*/ 2U;
    if (u16_Out < model_ref_U.In2) {
        u16_Out = MAX_uint16_T;
    }
}

SimSubE(&model_ref_U.In2, &model_ref_U.In3, &u16_Model);
switch (model_ref_U.In1) {
    case 0:
        model_ref_Y.Out1 = (model_ref_U.In2 + model_ref_U.In3) * 5U;
        break;

    case 1:
        model_ref_Y.Out1 = u16_Out_m;
        break;

    case 2:
        model_ref_Y.Out1 = u16_Out;
        break;

    default:
        model_ref_Y.Out1 = u16_Model;
        break;
}
}
```

In the `model_ref_step` function, there are three local variables. The `if-else` statements are above the `switch-case` statements, so they are unconditionally executed.

In R2017a, the code generator produces this code:

```
/* Model step function */
```

```
void model_ref_step(void)
{
    /* local block i/o variables */
    uint16_T u16_Model;
    uint16_T u16_qY;
    SimSubE(&model_ref_U.In2, &model_ref_U.In3, &u16_Model);
    switch (model_ref_U.In1) {
        case 0:
            model_ref_Y.Out1 = (model_ref_U.In2 + model_ref_U.In3) * 5U;
            break;

        case 1:
            if (model_ref_U.In3 > 30U) {
                u16_qY = model_ref_U.In2 + /*MW:0vSat0k*/ 5U;
                if (u16_qY < model_ref_U.In2) {
                    u16_qY = MAX_uint16_T;
                }

                model_ref_Y.Out1 = u16_qY;
            } else {
                u16_qY = model_ref_U.In2 + /*MW:0vSat0k*/ 12U;
                if (u16_qY < model_ref_U.In2) {
                    u16_qY = MAX_uint16_T;
                }

                model_ref_Y.Out1 = u16_qY;
            }
            break;

        case 2:
            if (model_ref_U.In2 > 20U) {
                model_ref_Y.Out1 = model_ref_U.In2 + model_ref_U.In3;
            } else {
                u16_qY = model_ref_U.In2 + /*MW:0vSat0k*/ 2U;
                if (u16_qY < model_ref_U.In2) {
                    u16_qY = MAX_uint16_T;
                }

                model_ref_Y.Out1 = u16_qY;
            }
            break;

        default:
            model_ref_Y.Out1 = u16_Model;
    }
}
```

```
        break;
    }
}
```

In the `model_ref_step` function, there are two local variables instead of three local variables which conserves stack space. Each `switch-case` statement includes the corresponding `if-else` statement. Including the `if-else` statements in the `switch-case` statements increases code execution speed because each `if-else` statement is only executed if the corresponding `case` statement is true.

## **Code Efficiency: Improve loop fusion for Sum of Elements blocks and generate less code for temporal logic in Stateflow**

### **Loop fusion for Sum of Elements blocks**

In R2017a, the code generator can fuse more `for` loops involving Sum of Elements blocks. This optimization conserves ROM consumption and improves code execution speed.

For example, the model `loop_fuse` contains a Sum of Elements block inside two nested For Each subsystems. The diagram shows the model `loop_fuse`, the For Each Subsystems and signal dimensions.

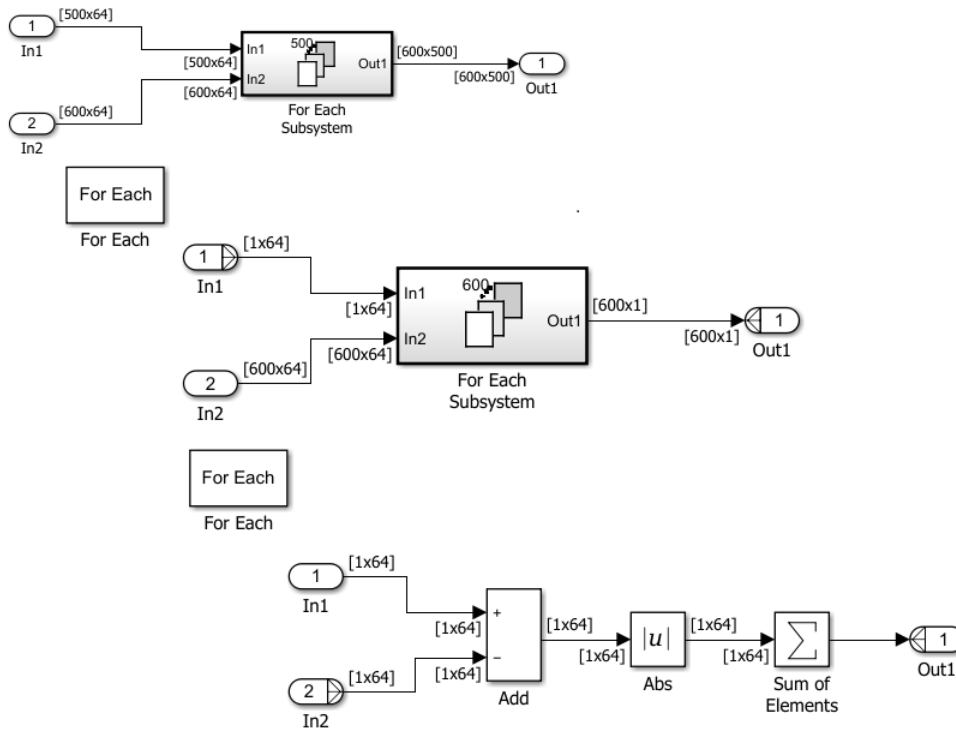

In R2016b, the code generator produced this code:

```
void loop_fuse_step(void)
{
    int32_T ForEach_itr;
    int32_T ForEach_itr_d;
    real_T tmp;
    real_T rtb_Abs[64];
    int32_T i;
    for (ForEach_itr = 0; ForEach_itr < 500; ForEach_itr++) {
        for (ForEach_itr_d = 0; ForEach_itr_d < 600; ForEach_itr_d++) {
            for (i = 0; i < 64; i++) {
                rtb_Abs[i] = fabs(loop_fuse_U.In1[500 * i + ForEach_itr] -
                                loop_fuse_U.In2[600 * i + ForEach_itr_d]);
            }
        }
    }
}
```

```
    tmp = rtb_Abs[0];
    for (i = 0; i < 63; i++) {
        tmp += rtb_Abs[i + 1];
    }

    loop_fuse_B.Out1_CoreSubsysCanOut[ForEach_itr_d] = tmp;
}

for (i = 0; i < 600; i++) {
    loop_fuse_Y.Out1[i + 600 * ForEach_itr] =
        loop_fuse_B.Out1_CoreSubsysCanOut[i];
}
}
```

The generated code contained separate for loops for the Add and Abs blocks and the Sum of Elements block.

In R2017a, the code generator produces this code:

```
void loop_fuse_step(void)
{
    int32_T ForEach_itr;
    int32_T ForEach_itr_d;
    real_T tmp;
    int32_T i;
    for (ForEach_itr = 0; ForEach_itr < 500; ForEach_itr++) {
        for (ForEach_itr_d = 0; ForEach_itr_d < 600; ForEach_itr_d++) {
            tmp = 0.0;
            for (i = 0; i < 64; i++) {
                tmp += fabs(loop_fuse_U.In1[500 * i + ForEach_itr] - loop_fuse_U.In2[600
                    * i + ForEach_itr_d]);
            }

            loop_fuse_B.Out1_CoreSubsysCanOut[ForEach_itr_d] = tmp;
        }

        for (i = 0; i < 600; i++) {
            loop_fuse_Y.Out1[i + 600 * ForEach_itr] =
                loop_fuse_B.Out1_CoreSubsysCanOut[i];
        }
    }
}
```

The generated code contains one `for` loop for the Add and Abs blocks and the Sum of Elements block.

### More efficient code for temporal logic in Stateflow

For some absolute-time constructs using fixed-point parameters, Stateflow generates more efficient code that does not contain floating-point operations.

For example, consider `after(DELAY, sec)` in a chart with a sample time of the chart  $< 1$  second. `DELAY` is a fixed-point parameter. Previously the code generator created the following code:

```
counter >= (uint32_T)ceil((real_T)DELAY * 0.05 / 0.1 - 1e-9)
```

Now, it generates:

```
(counter >> 1) >= DELAY
```

This code contains fewer operations and does not include floating-point operations.

### Data copy reduction for Merge blocks

In R2017a, the code generator is improved to better reuse buffers around Merge blocks. This optimization conserves RAM and ROM consumption and increases code execution speed.

For example, the model `cond_reuse` contains the virtual subsystem `Subsystem1`. `Subsystem1` contains an `if-else` conditional structure that connects to a Merge block.

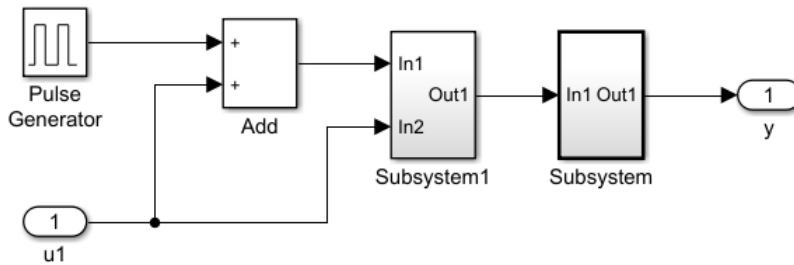

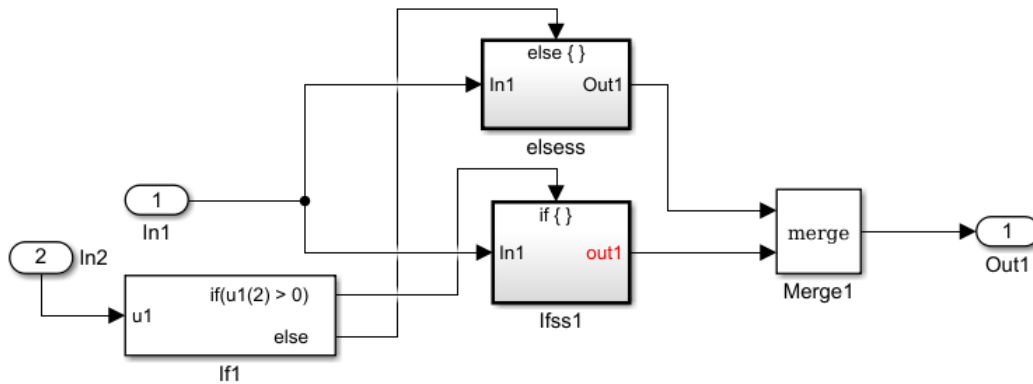

In R2016b, the code generator produced this code:

```

B_cond_reuse_T cond_reuse_B;
DW_cond_reuse_T cond_reuse_DW;
ExtU_cond_reuse_T cond_reuse_U;
ExtY_cond_reuse_T cond_reuse_Y;
RT_MODEL_cond_reuse_T cond_reuse_M;
RT_MODEL_cond_reuse_T *const cond_reuse_M = &cond_reuse_M;
void cond_reuse_Subsystem(void)
{
    int32_T i;
    for (i = 0; i < 64; i++) {
        cond_reuse_Y.y[i] = -3.0 * cond_reuse_B.Merge1[i];
    }
}
void cond_reuse_step(void)
{
    int32_T rtb_PulseGenerator;
    real_T rtb_Add[64];
    int32_T i;
    rtb_PulseGenerator = ((cond_reuse_DW.clockTickCounter < 1) &&
        (cond_reuse_DW.clockTickCounter >= 0));
    if (cond_reuse_DW.clockTickCounter >= 19) {
        cond_reuse_DW.clockTickCounter = 0;
    } else {
        cond_reuse_DW.clockTickCounter++;
    }

    for (i = 0; i < 64; i++) {

```



```

    rtb_Add[i] = (real_T)rtb_PulseGenerator + cond_reuse_U.u1[i];
}

if (cond_reuse_U.u1[1] > 0.0) {
    memcpy(&cond_reuse_B.Merge1[0], &rtb_Add[0], sizeof(real_T) << 6U);
} else {
    for (i = 0; i < 64; i++) {
        cond_reuse_B.Merge1[i] = 22.0 * rtb_Add[i] * -3.0;
    }
}

cond_reuse_Subsystem();
}

```

The generated code contained full data copies to the temporary arrays `rtb_Add` and `cond_reuse_B.Merge1`.

In R2017a, the code generator produces this code:

```

DW_cond_reuse_T cond_reuse_DW;
ExtU_cond_reuse_T cond_reuse_U;
ExtY_cond_reuse_T cond_reuse_Y;
RT_MODEL_cond_reuse_T cond_reuse_M_;
RT_MODEL_cond_reuse_T *const cond_reuse_M = &cond_reuse_M_;
void cond_reuse_Subsystem(void)
{
    int32_T i;
    for (i = 0; i < 64; i++) {
        cond_reuse_Y.y[i] *= -3.0;
    }
}
void cond_reuse_step(void)
{
    int32_T rtb_PulseGenerator;
    int32_T i;
    rtb_PulseGenerator = ((cond_reuse_DW.clockTickCounter < 1) &&
        (cond_reuse_DW.clockTickCounter >= 0));
    if (cond_reuse_DW.clockTickCounter >= 19) {
        cond_reuse_DW.clockTickCounter = 0;
    } else {
        cond_reuse_DW.clockTickCounter++;
    }

    if (cond_reuse_U.u1[1] > 0.0) {
        for (i = 0; i < 64; i++) {

```

```
        cond_reuse_Y.y[i] = (real_T)rtb_PulseGenerator + cond_reuse_U.u1[i];
    }
} else {
    for (i = 0; i < 64; i++) {
        cond_reuse_Y.y[i] = ((real_T)rtb_PulseGenerator + cond_reuse_U.u1[i]) *
            22.0 * -3.0;
    }
}

cond_reuse_Subsystem();
}
```

The temporary arrays `rtb_Add` and `cond_reuse_B.Merge1` and their associated data copies are not in the generated code. For the preceding model, you can also specify buffer reuse using `Simulink.Signal` objects. See “Specify Buffer Reuse for Multiple Signals in a Path”.

## More instances of buffer reuse for blocks and subsystems in a chain

In R2017a, the code generator can automatically reuse buffers for more modeling patterns involving blocks and subsystems in a chain. Specifically, the code generator can reuse buffers for these modeling patterns:

- A chain of blocks that includes reusable and nonreusable subsystems
- A chain of reusable subsystems
- A chain of blocks that includes a root-level Output block
- A chain of blocks that includes a mixture of signals with auto and reusable custom storage class specifications. However, the reusable custom storage class specification must be on a signal that leaves a root-level Inport block or enters a root-level Output block.

---

**Note:** For buffer reuse to occur for these modeling patterns, in the Configuration Parameters dialog box, on the **All Parameters** tab, set the **Optimize global data access** parameter to **Use global** to hold temporary results. For models containing reusable subsystems, on the **Optimization > Signals and Parameters** tab, set the **Pass reusable subsystem outputs as** parameter to **Individual arguments**.

---

These optimizations reduce data copies in the generated code thereby conserving RAM and ROM consumption and improving code execution speed.

### Buffer reuse for a chain of reusable and nonreusable subsystems

The code generator can now reuse buffers for a chain of reusable and nonreusable subsystems. This chain can include a root-level Output block. It can also contain a mixture of signals with auto and reusable custom storage class specifications. However, the reusable custom storage class specification must be on a signal that leaves a root-level Inport block or enters a root-level Output block.

For example, the model `Chainbuffer` contains the reusable subsystems `Subsystem`, `Subsystem1`, and `Subsystem2`. For a reusable subsystem, the generated code is a function with arguments.

The model also contains the nonreusable subsystem `Subsystem3`. For `Subsystem3`, the **Function interface** parameter has a value of `void-void`. The signal leaving `u` and entering `Out1` resolves to the `Simulink.signal X`. `X` has a reusable custom storage class.

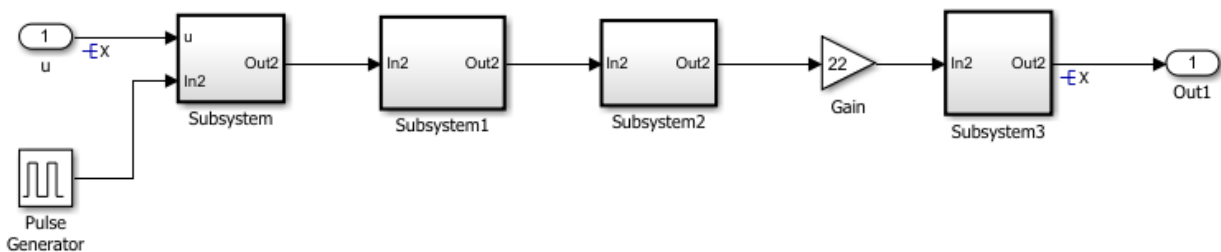

In R2016b, the code generator produced this code.

```
real_T X[64];
B_Chainbuffer_T Chainbuffer_B;
...
void Chainbuffer_Subsystem3(void)
{
    int32_T i;
    for (i = 0; i < 64; i++) {
        X[i] = 22.0 * Chainbuffer_B.Gain[i] * 22.0;
    }
}
void Chainbuffer_step(void)
{
    int32_T rtb_PulseGenerator;
    real_T rtb_Gain1_o[64];
    real_T rtb_Gain1_a[64];
```

```
rtb_PulseGenerator = ((Chainbuffer_DW.clockTickCounter < 1) &&
                      (Chainbuffer_DW.clockTickCounter >= 0));
if (Chainbuffer_DW.clockTickCounter >= 19) {
    Chainbuffer_DW.clockTickCounter = 0;
} else {
    Chainbuffer_DW.clockTickCounter++;
}

Chainbuffer_Subsystem((&(X[0])), (real_T)rtb_PulseGenerator, rtb_Gain1_o);
Chainbuffer_Subsystem1(rtb_Gain1_o, rtb_Gain1_a);
Chainbuffer_Subsystem1(rtb_Gain1_a, Chainbuffer_B.Gain);
for (rtb_PulseGenerator = 0; rtb_PulseGenerator < 64; rtb_PulseGenerator++) {
    Chainbuffer_B.Gain[rtb_PulseGenerator] *= 22.0;
}

Chainbuffer_Subsystem3();
}
```

The generated code contained the global buffer `Chainbuffer_B.Gain` and the local buffers `rtb_Gain1_o` and `rtb_Gain1_a` for holding the inputs and outputs of `Subsystem`, `Subsystem1`, `Subsystem2`, and `Subsystem3`.

In R2017a, the code generator produces this code.

```
real_T X[64];
...
void Chainbuffer_Subsystem3(void)
{
    int32_T i;
    for (i = 0; i < 64; i++) {
        X[i] = 22.0 * X[i] * 22.0;
    }
}

void Chainbuffer_step(void)
{
    int32_T rtb_PulseGenerator;
    rtb_PulseGenerator = ((Chainbuffer_DW.clockTickCounter < 1) &&
                        (Chainbuffer_DW.clockTickCounter >= 0));
    if (Chainbuffer_DW.clockTickCounter >= 19) {
        Chainbuffer_DW.clockTickCounter = 0;
    } else {
        Chainbuffer_DW.clockTickCounter++;
    }

    Chainbuffer_Subsystem((&(X[0])), (real_T)rtb_PulseGenerator, (&(X[0])));
}
```

```

Chainbuffer_Subsystem1((&(X[0])), (&(X[0]]));
Chainbuffer_Subsystem1((&(X[0])), (&(X[0]]));
for (rtb_PulseGenerator = 0; rtb_PulseGenerator < 64; rtb_PulseGenerator++) {
    X[rtb_PulseGenerator] = 22.0 * X[rtb_PulseGenerator];
}

Chainbuffer_Subsystem3();
}

```

The generated code contains the global buffer X for holding the inputs and outputs of Subsystem, Subsystem1, Subsystem2, and Subsystem3.

### Buffer reuse for a chain of reusable subsystems

The code generator can now reuse the arguments of reusable subsystems in a chain.

For example, the model `subtreuse` contains four subsystems. For the four subsystems, in the Subsystem Block Parameters dialog box, on the **Code Generation** tab, the **Function packaging** parameter is set to **Reusable function**. The input and output signals resolve to the `Simulink.Signal X`. This signal has a **Storage class** of **Reusable (Custom)**.

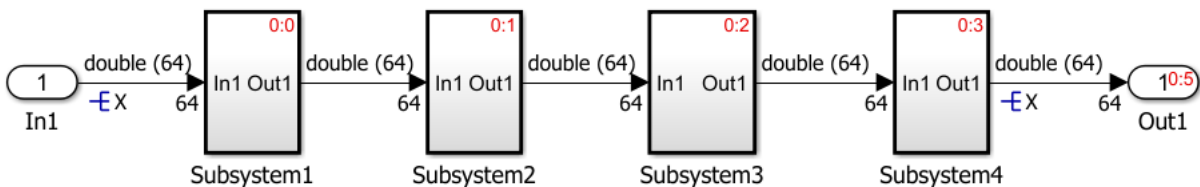

In R2016b, the code generator produced this code:

```

void subtreuse_step(void)
{
    real_T rtb_Gain_n[64];
    real_T rtb_Gain_m[64];
    subtreuse_Subsystem1((&(X[0])), rtb_Gain_n, (P_Subsystem1_subtreuse_T *)
        &subtreuse_P.Subsystem1);
    subtreuse_Subsystem2(rtb_Gain_n, rtb_Gain_m, (P_Subsystem2_subtreuse_T *)
        &subtreuse_P.Subsystem2);
    subtreuse_Subsystem2(rtb_Gain_m, rtb_Gain_n, (P_Subsystem2_subtreuse_T *)
        &subtreuse_P.Subsystem4);
    subtreuse_Subsystem1(rtb_Gain_n, (&(X[0])), (P_Subsystem1_subtreuse_T *)
        &subtreuse_P.Subsystem3);
}

```

The code contained two temporary variables, `rtb_Gain_n` and `rtb_Gain_m`, for holding the input and output of each function.

In R2017a, the code generator produces this code:

```
void subsreuse_step(void)
{
    subsreuse_Subsystem1((&(X[0])), (&(X[0])), (P_Subsystem1_subsrreuse_T *)
        &subsreuse_P.Subsystem1);
    subsreuse_Subsystem2((&(X[0])), (&(X[0])), (P_Subsystem2_subsrreuse_T *)
        &subsreuse_P.Subsystem2);
    subsreuse_Subsystem2((&(X[0])), (&(X[0])), (P_Subsystem2_subsrreuse_T *)
        &subsreuse_P.Subsystem3);
    subsreuse_Subsystem1((&(X[0])), (&(X[0])), (P_Subsystem1_subsrreuse_T *)
        &subsreuse_P.Subsystem4);
}
```

The generated code uses one global variable `X` for the input and output of each function.

## Improved buffer reuse due to changes in block execution order

In R2016b, if you specified a signal for reuse, the code generator changed the block operation order so that buffer reuse occurred.

In R2017a, even if you do not specify a signal for reuse, the code generator can change the block operation order so that buffer reuse can occur. If the generated code contains extra buffers, you can try to eliminate them by setting the **Optimize block operation order in the generated code** parameter to **Improve Execution Speed**. In the Configuration Parameters dialog box, this parameter is on the **All Parameters** tab. Reusing buffers conserves RAM and ROM consumption and improves code execution speed.

For example, for the model `rtwdemo_optimizeblockorder`, the red numbers that follow the zeroes and colons represent the block execution order in R2016b. The Matrix Concatenate block executes after the Subtract block. The Sum of Elements block executes after the Product block. This block execution order prevents the same variables from being reused as the input and output to the Subtract and Product blocks in the generated code. As a result, there are two extra temporary arrays, two extra variables, and associated data copies for holding the inputs to these blocks.

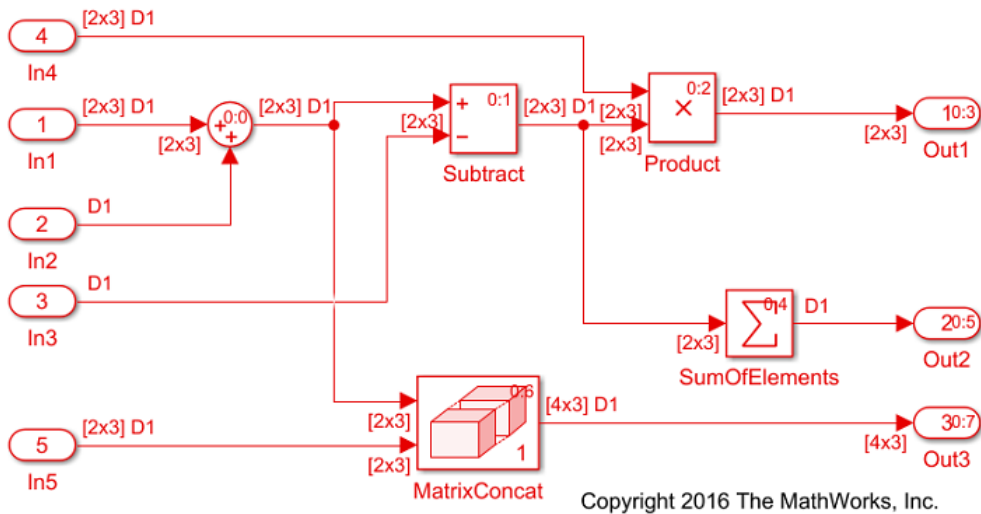

In R2017a, the code generator can reorder the block execution order so that the Matrix Concatenate block executes before the Subtract block and the Sum of Elements block executes before the Product block. Reordering block operations eliminates the two temporary arrays, the two variables, and their associated data copies from the generated code. The blocks can use the same variable for the input and output.

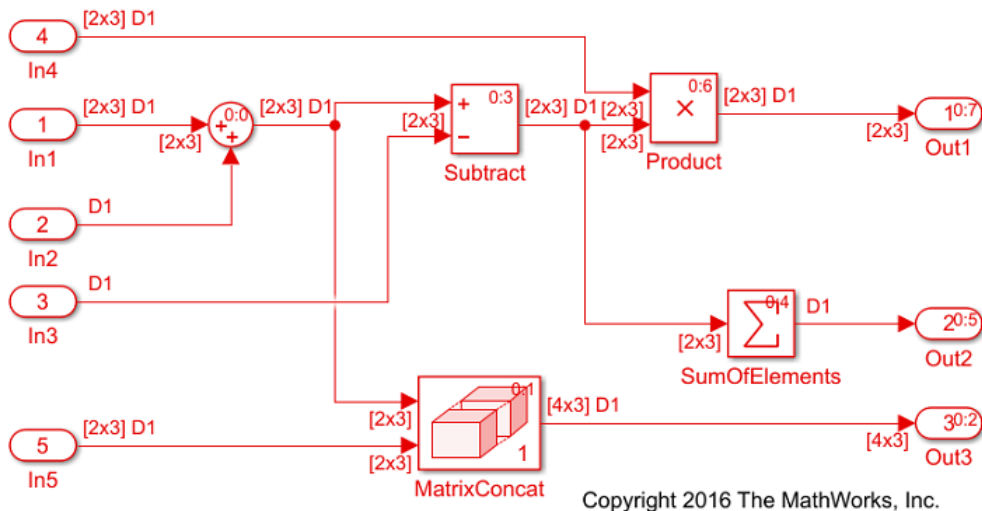

**Note:** To implement buffer reuse, the code generator does not violate user-specified block priorities.

For more information, see “Remove Data Copies by Reordering Block Operations in the Generated Code”.

### More efficient code for Bus Creator blocks

In R2017a, the generated code contains additional optimizations for modeling patterns involving Bus Creator blocks. These optimizations include turning global variables into local variables, buffer elimination, data copy reduction, and expression folding. The optimizations improve ROM and RAM consumption and increase code execution speed.

For example, the model `bus_creator_ex` contains two Bus Creator blocks.





In R2016b, the `bus_creator.c` file contained this code:

```
void bus_creator_ex_step(void)
{
    Ifx_DPResultU16_Type dpResult;
    Ifx_DPResultU16_Type dpResult_0;
    Ifx_DPSearch_u8(&dpResult,
                   bus_creator_ex_ConstP.Vector_Value[bus_creator_ex_DW.Output_DSTATE],
                   2U, (*Rte_CData_BP1_SlopeBiasScaling_0_8_Op5_0()));
    bus_creator_ex_B.Ifz_DPResultU16_Type_h.Index = dpResult.Index;
    bus_creator_ex_B.Ifz_DPResultU16_Type_h.Ratio = dpResult.Ratio;
    dpResult_0.Index = bus_creator_ex_B.Ifz_DPResultU16_Type_h.Index;
    dpResult_0.Ratio = bus_creator_ex_B.Ifz_DPResultU16_Type_h.Ratio;
    bus_creator_ex_Y.Out6 = Ifx_IpoCur_u8(&dpResult_0,
                                           (*Rte_CData_TB1_SlopeBiasScaling_0_8_Op5_0()));
    bus_creator_ex_DW.Output_DSTATE++;
}
```

The code contained two local variables `dpResult` and `dpResult_0` for holding values prior to and from the Bus Creator blocks.

In R2017a, the `bus_creator.c` file contains this code:

```
void bus_creator_ex_step(void)
{
    Ifx_DPResultU16_Type dpResult;
    Ifx_DPSearch_u8(&dpResult,
                   bus_creator_ex_ConstP.Vector_Value[bus_creator_ex_DW.Output_DSTATE],
                   2U, (*Rte_CData_BP1_SlopeBiasScaling_0_8_Op5_0()));
    bus_creator_ex_B.Ifz_DPResultU16_Type_h.Index = dpResult.Index;
    bus_creator_ex_B.Ifz_DPResultU16_Type_h.Ratio = dpResult.Ratio;
    dpResult.Index = bus_creator_ex_B.Ifz_DPResultU16_Type_h.Index;
    dpResult.Ratio = bus_creator_ex_B.Ifz_DPResultU16_Type_h.Ratio;
    bus_creator_ex_Y.Out6 = Ifx_IpoCur_u8(&dpResult,
                                           (*Rte_CData_TB1_SlopeBiasScaling_0_8_Op5_0()));
    bus_creator_ex_DW.Output_DSTATE++;
}
```

The generated code contains one less local variable.

## Buffer reuse for Variant Source blocks

In R2017a, the code generator can reuse the buffer for Variant Source blocks.

For example, the model VariantMergeReuse contains two Variant Source blocks.

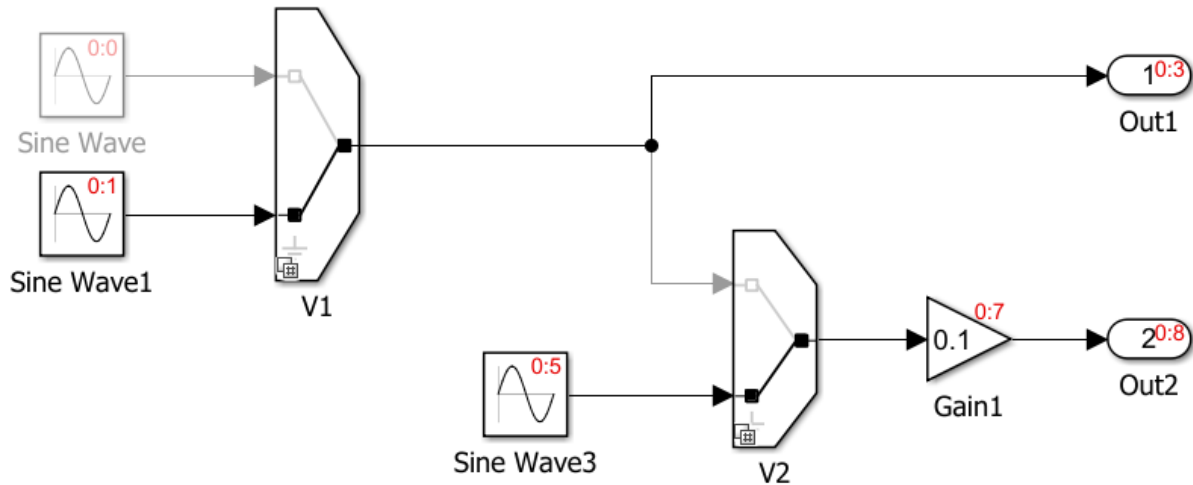

In R2016b, the code generator produced this code in the VariantMergeReuse step function:

```
#if V == 1 || V == 2
    real_T rtb_VariantMerge_For_Variant_So;
#endif
/* V == 1 || V == 2 */
#if (V == 1 && W == 1) || (V == 2 && W == 1) || W == 2
    real_T rtb_VariantMerge_For_Variant_k;
#endif
```

The code contained two buffers for holding intermediate values.

In R2017a, the code generator produces this code in the VariantMergeReuse step function:

```
#if V == 1 || V == 2 || W == 2
    real_T rtb_VariantMerge_For_Variant_So;
```

```
#endif                                     /* V == 1 || V == 2 || W == 2 */
```

The code contains one buffer for holding intermediate values.

## Verification

### SIL and PIL Testing: Log signals inside exported functions and stream signals to Simulation Data Inspector during simulation

To examine internal signals of a model component, you can enable internal signal logging for a top-model or Model block software-in-the-loop (SIL) or processor-in-the-loop (PIL) simulation. In R2017a, you can:

- Log signals inside export-function models.
- Stream the logged signals to the Simulation Data Inspector, where you can observe the signals during the SIL or PIL simulation.

For more information, see:

- “Log Internal Signals of a Component”
- “Export-Function Models” (Simulink)
- “General SIL and PIL Limitations”

### Verification of PIL target connectivity configuration

The `piltest` function provides additional tests for verifying your custom processor-in-the-loop (PIL) target connectivity configuration.

'Testpoint' Argument Value	Description
'verifyTopModelSILPILSwitching'	New in R2017a.  For a Simulink top model, the function: <ul style="list-style-type: none"> <li>• Verifies that production code is not regenerated when the simulation mode switches between software-in-the-loop (SIL) and PIL. The function compares timestamps of the production code used in each mode.</li> <li>• Compares results from SIL and PIL mode simulations to results from a normal mode simulation.</li> </ul>
'verifyModelBlockSILPILSwitchin	New in R2017a.  For a Simulink Model block, the function:

'Testpoint' Argument Value	Description
	<ul style="list-style-type: none"> <li>• Verifies that production code is not regenerated when the Model block simulation mode switches between SIL and PIL. The function compares timestamps of the production code used in each mode.</li> <li>• Runs simulation loops with the Model block in SIL and PIL modes. The function varies the <b>Code interface</b> Model block parameter, setting this parameter to <code>Top model</code> or <code>Model</code> reference.</li> </ul> <p>The function compares results from SIL and PIL mode simulations to results from a normal mode simulation.</p>
'verifyModelBlock'	<p>Updated in R2017a.</p> <p>The function runs simulation loops with a Simulink Model block in PIL mode. The function varies the <b>Configuration Parameters &gt; Code Generation &gt; Language</b> parameter, setting this parameter to <code>C</code> or <code>C++</code>. For <code>C++</code>, the function sets <b>Code Generation &gt; Interface &gt; Code interface packaging</b> to <code>C++ class</code>.</p> <p>Previously, <b>Language</b> was set to <code>C</code>.</p>

For more information, see “Create PIL Target Connectivity Configuration”.

## Check bug reports for issues and fixes

Software is inherently complex and is not free of errors. The output of a code generator might contain bugs, some of which are not detected by a compiler. MathWorks reports critical known bugs brought to its attention on its Bug Report system at [www.mathworks.com/support/bugreports/](http://www.mathworks.com/support/bugreports/). Use the Saved Searches and Watched Bugs tool with the search phrase "Incorrect Code Generation" to obtain a report of known bugs that produce code that might compile and execute, but still produce wrong answers.

The bug reports are an integral part of the documentation for each release. Examine periodically all bug reports for a release, as such reports may identify inconsistencies between the actual behavior of a release you are using and the behavior described in this documentation.

In addition to reviewing bug reports, you should implement a verification and validation strategy to identify potential bugs in your design, code, and tools.

# R2016b

**Version: 6.11**

**New Features**

**Bug Fixes**

**Compatibility Considerations**

## Code Generation from MATLAB Code

### Static code metrics report for C++ code

In R2016b, when you generate standalone C++ code, the HTML code generation report includes a static code metrics report. See [Generate a Static Code Metrics Report for MATLAB Code and Static Code Metrics](#).

### Verification of `size_t` and `ptrdiff_t` hardware settings

In the project build settings, on the **Hardware** tab, R2016b provides values for the ANSI<sup>®</sup> C data types `size_t` and `ptrdiff_t`. At the start of a processor-in-the-loop (PIL) execution, the software verifies the values with reference to the target hardware.

### Verification of PIL target connectivity configuration

Through the `piltest` function, you can use a test suite to verify your custom processor-in-the-loop (PIL) target connectivity configuration. Verify the target connectivity configuration early and independently of your algorithm development and code generation.

For more information, see:

- [Create PIL Target Connectivity Configuration](#)
- [PIL Execution of Code Generated for a Kalman Estimator](#)

### Optimization for array indexing in loops

In R2016b, if you use Embedded Coder to generate C/C++ code from MATLAB code, you can enable an optimization that simplifies array indexing in loops in the generated code. When possible, for array indices in loops, this optimization replaces multiply operations with add operations. Multiply operations can be expensive. This optimization, referred to as strength reduction, is useful when the C/C++ compiler on the target platform does not optimize the array indexing.

Here is code generated without the optimization:

```
for (i = 0; i < 10; i++) {
```



```
    z[5 * (1 + i) - 1] = x[5 * (1 + i)];  
}
```

Here is code generated with the optimization:

```
for (b_i = 0; b_i < 10; b_i++) {  
    z[i + 4] = x[i + 5];  
    i += 5;  
}
```

By default, the strength reduction optimization is disabled. To enable it:

- At the command line, set the configuration object parameter `EnableStrengthReduction` to `true`.
- In the MATLAB Coder app, project build settings, on the **All Settings** tab, set **Simplify array indexing** to **Yes**.

Even when the optimization replaces the multiply operations in the generated code, it is possible that the C/C++ compiler can generate multiply instructions.

## Reduction of the Intel Performace Primitives (IPP) code replacement libraries (CRL)

The code replacement libraries (CRL) related to features, such as matrix multiple and dot product, that are no longer supported by the Intel Performace Primitives (IPP) library will be removed in a future release.

## Model Architecture and Design

### **AUTOSAR Basic Software (BSW) Services: Simulate BSW including Diagnostic Event Manager (DEM) and NVRAM Manager (NvM)**

The AUTOSAR standard defines important services as part of Basic Software (BSW) that runs in the AUTOSAR runtime environment (RTE). Examples include the NVRAM Manager (NvM) and the Diagnostic Event Manager (Dem). In the AUTOSAR RTE, AUTOSAR software components typically access BSW services using client-server or sender-receiver communication.

To support system-level modeling of AUTOSAR components and services, R2016b adds an AUTOSAR Basic Software block library. The library contains preconfigured Function Caller blocks for modeling component calls to AUTOSAR BSW services.

- Diagnostic Event Manager (Dem) blocks — Calls to Dem service interfaces, including `CallbackEventStatusChangeCaller`, `DiagnosticInfoCaller`, and `DiagnosticMonitorCaller`.
- NVRAM Manager (NvM) blocks — Calls to NvM service interfaces, including `NvMAdminCaller` and `NvMServiceCaller`.

To implement client calls to AUTOSAR BSW service interfaces in your AUTOSAR software component, you drag and drop Basic Software blocks into an AUTOSAR model and click a **Synchronize** icon. The software automatically configures the client calls in the AUTOSAR configuration. For more information, see [Model AUTOSAR Basic Software \(BSW\) Service Calls](#), [Configure Calls to AUTOSAR Diagnostic Event Manager \(Dem\) Service](#), and [Configure Calls to AUTOSAR NVRAM Manager \(NvM\) Service](#).

### **AUTOSAR Parameters: Model STD\_AXIS and COM\_AXIS lookup table parameters, export SwRecordLayouts, and apply SwAddrMethods**

R2016b enhances AUTOSAR calibration parameter and data modeling with additional support for:

- “AUTOSAR STD\_AXIS and COM\_AXIS lookup tables” on page 2-5
- “AUTOSAR port-based and internal calibration parameters” on page 2-5
- “AUTOSAR SwRecordLayouts for lookup tables” on page 2-6
- “AUTOSAR SwAddrMethods for measurement and calibration tools” on page 2-6

## **AUTOSAR STD\_AXIS and COM\_AXIS lookup tables**

AUTOSAR applications can use lookup tables in either or both of two ways:

- Implement high-performance search operations.
- Support tuning of the application with measurement and calibration tools.

To model lookup tables for automotive application tuning, use the new classes `Simulink.LookupTable` and `Simulink.Breakpoint` to store tunable table and breakpoint data. Simulink lookup table blocks have additional parameters to support the use of `Simulink.LookupTable` and `Simulink.Breakpoint` objects. AUTOSAR models can leverage the new classes to model `STD_AXIS` and `COM_AXIS` lookup tables. In Simulink, you can:

- Import `arxml` files that contain AUTOSAR lookup tables in `STD_AXIS` and `COM_AXIS` configurations.
- Create `STD_AXIS` and `COM_AXIS` lookup tables and map them to AUTOSAR parameters. In R2016b, you can create AUTOSAR parameters for lookup tables graphically, using the AUTOSAR Properties Explorer, or programmatically, using AUTOSAR property functions. For more information, see “AUTOSAR port-based and internal calibration parameters” on page 2-5.
- Generate `arxml` and C code with `STD_AXIS` and `COM_AXIS` lookup table content.

For more information, see [Configure STD\\_AXIS and COM\\_AXIS Lookup Tables for AUTOSAR Measurement and Calibration](#).

## **AUTOSAR port-based and internal calibration parameters**

To support mapping a Simulink lookup table to an AUTOSAR parameter, you can now create AUTOSAR calibration parameters (`ParameterDataPrototypes`) using the AUTOSAR Properties Explorer or AUTOSAR property functions. You can create either internal AUTOSAR parameters, defined and accessed only within your software component, or port-based AUTOSAR parameters, associated with a port-based parameter interface.

The AUTOSAR parameters that you create subsequently are available for Simulink lookup table mapping, using the Simulink-AUTOSAR Mapping Explorer or AUTOSAR map functions.

For more information, see [Configure AUTOSAR Port-Based Calibration Parameters](#).

### **AUTOSAR SwRecordLayouts for lookup tables**

AUTOSAR software components use software record layouts (`SwRecordLayouts`) to specify how to serialize data in the memory of an AUTOSAR ECU. The `arxml` importer imports and preserves the `SwRecordLayout` property for AUTOSAR data.

R2016b allows you to import `SwRecordLayouts` from `arxml` files in either of two ways:

- If you create your AUTOSAR model from `arxml` files using importer method `createComponentAsModel`, include an `arxml` file that contains `SwRecordLayout` definitions in the import. The imported `SwRecordLayouts` are preserved and subsequently exported in `arxml` code.
- If you create your AUTOSAR model in Simulink, you can import reference definitions of `SwRecordLayouts` from `arxml` files. When you generate model code, the exported `arxml` code contains references to the imported read-only `SwRecordLayout` elements, but not their definitions.

For more information, see [Configure AUTOSAR Data for Measurement and Calibration](#).

### **AUTOSAR SwAddrMethods for measurement and calibration tools**

AUTOSAR software components use software address methods (`SwAddrMethods`) to group data in memory for access by measurement and calibration tools. In an AUTOSAR software component configuration, you assign common memory sections to data. When the runtime environment instantiates calibration parameters, calibration parameters that reference the same `SwAddrMethod` are placed within the same calibration parameter group.

The `arxml` importer imports and preserves the `SwAddrMethod` property for AUTOSAR data. In previous releases, in Simulink, you could assign memory sections to global constant and static memory, using AUTOSAR data objects. But you could not assign `SwAddrMethods` or memory sections to data accessed by RTE function calls, such as sender-receiver (S-R) interface data elements or inter-runnable variables (IRVs).

R2016b allows you to graphically or programmatically select imported `SwAddrMethod` values for AUTOSAR data accessed by RTE function calls.

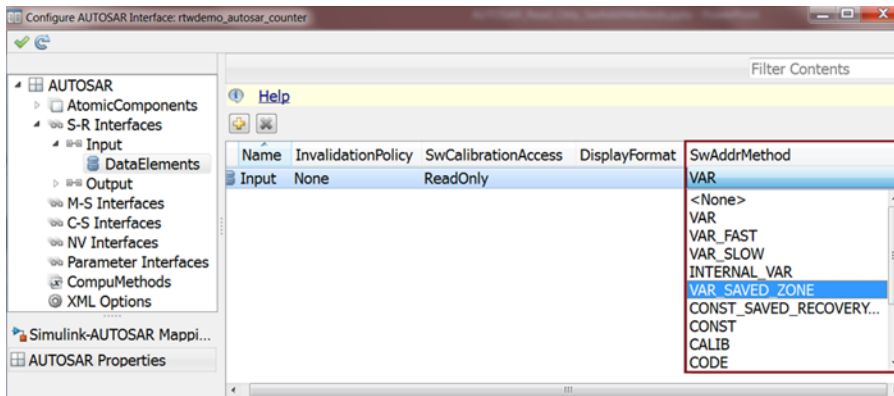

When you build the model, the exported arxml code reflects the SwAddrMethod values you selected.

```
<SENDER-RECEIVER-INTERFACE>
  <SHORT-NAME>Input</SHORT-NAME>
  <IS-SERVICE>>false</IS-SERVICE>
  <DATA-ELEMENTS>
    <VARIABLE-DATA-PROTOTYPE>
      <SHORT-NAME>Input</SHORT-NAME>
      <CATEGORY>VALUE</CATEGORY>
      ...
      <SW-DATA-DEF-PROPS>
        <SW-ADDR-METHOD-REF DEST="SW-ADDR-METHOD">
          /AUTOSAR/MemMap/SwAddrMethods_Blueprint/VAR_SAVED_ZONE</SW-ADDR-METHOD-REF>
        ...
      </SW-DATA-DEF-PROPS>
      ...
    </VARIABLE-DATA-PROTOTYPE>
  </DATA-ELEMENTS>
</SENDER-RECEIVER-INTERFACE>
```

For more information, see Configure AUTOSAR Data for Measurement and Calibration.

## AUTOSAR startup, reset, and shutdown modeling

AUTOSAR applications sometimes require complex logic to execute during system initialization, reset, and termination sequences. R2016b introduces the Simulink blocks Initialize Function and Terminate Function. You can use these blocks to control execution of a component in response to initialize, reset, or terminate events at any level of a model hierarchy. Each nonvirtual subsystem can have its own set of initialize, reset, and terminate functions. In a lower-level model, Simulink aggregates the content of the functions with corresponding instances in the parent model.

AUTOSAR models can leverage the new blocks to model potentially complex AUTOSAR startup, reset, and shutdown sequences. The subsystems work with any AUTOSAR component modeling style.

For more information, see Startup, Reset, and Shutdown and Configure AUTOSAR Initialize, Reset, or Terminate Runnables.

## **AUTOSAR external trigger event communication**

AUTOSAR Release 4.0 introduced external trigger event communication, in which an AUTOSAR component or service signals an external trigger occurred event (`ExternalTriggerOccurredEvent`) to another component. The receiving component activates a runnable in response to the event.

Embedded Coder now supports modeling the receiver portion of AUTOSAR external trigger event communication. In a component that you want to react to an external trigger, you create a trigger interface, a trigger receiver port to receive an `ExternalTriggerOccurredEvent`, and a runnable that is activated by the event.

For more information, see Configure Receiver for AUTOSAR External Trigger Event Communication.

## **AUTOSAR support for JMAAB model architecture**

Embedded Coder supports AUTOSAR code generation for the model architectures described in the Japan MBD Automotive Advisory Board (JMAAB) document *Control Algorithm Modeling Guidelines Using MATLAB, Simulink, and Stateflow - Version 4.01*. The document is available from the MAAB Web page at <http://www.mathworks.com/solutions/automotive/standards/maab.html>.

The document describes three layouts for the top layer of a controller model:

- Simple control model — Represents a functions layer and a scheduling layer in one layer.
- Complex control model type alpha ( $\alpha$ ) — Places a scheduling layer above function layers.
- Complex control model type beta ( $\beta$ ) — Places function layers above scheduling layers.

R2016b adds support for JMAAB type beta modeling in AUTOSAR models. For example, here is an AUTOSAR example model, `rtwdemo_autosar_sw_cncalls`,

in which an asynchronous function-call runnable at the top level of the model interacts with a periodic rate-based runnable. This type of component leverages periodic and asynchronous rates (sample times).

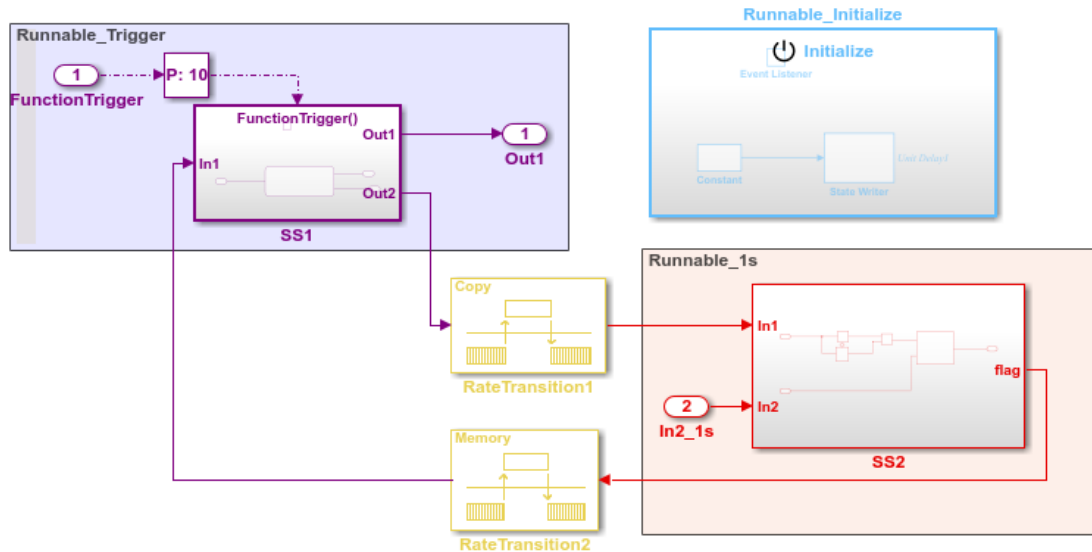

For more information about this component modeling style, see `.Add Top-Level Asynchronous Trigger to Periodic Rate-Based System`.

## AUTOSAR `ExplicitReceiveByVal` data access mode for receiver ports

R2016b adds support for modeling scalar explicit read by value access for AUTOSAR receiver ports, and generating the corresponding AUTOSAR API `Rte_DRead` in C code. Reading data by value can produce more efficient and readable C code and reduce RAM requirements.

In Simulink, you can model the data access in the following ways:

- Import an `arxml` file that uses `DATA-RECEIVE-POINT-BY-VALUES` variable access for a port. The importer creates a root inport with `ExplicitReceiveByVal` data access and maps it to an AUTOSAR receiver port.
- Create a root inport, select `ExplicitReceiveByVal` data access, and map it to an AUTOSAR receiver port.

When you build the model, the exported arxml code defines DATA-RECEIVE-POINT-BY-VALUES variable access for the AUTOSAR receiver port.

```
<RUNNABLE-ENTITY UUID="...">
...
<SHORT-NAME>Runnable_Step</SHORT-NAME>
...
<DATA-RECEIVE-POINT-BY-VALUES>
  <VARIABLE-ACCESS UUID="...">
    <SHORT-NAME>IN_Input_Input</SHORT-NAME>
    <ACCESSED-VARIABLE>
      <AUTOSAR-VARIABLE-IREF>
        <PORT-PROTOTYPE-REF DEST="R-PORT-PROTOTYPE">
          /pkg/swc/rtwdemo_autosar_counter/Inport</PORT-PROTOTYPE-REF>
        <TARGET-DATA-PROTOTYPE-REF DEST="VARIABLE-DATA-PROTOTYPE">
          /pkg/if/Input/Input</TARGET-DATA-PROTOTYPE-REF>
        </AUTOSAR-VARIABLE-IREF>
      </ACCESSED-VARIABLE>
    </VARIABLE-ACCESS>
  </DATA-RECEIVE-POINT-BY-VALUES>
...
</RUNNABLE-ENTITY>
```

The generated C code uses Rte\_DRead API calls to receive the port data by value.

```
void Runnable_Step(void)
{
...
/* Gain: '<S1>/Gain' incorporates:
 * Inport: '<Root>/Input'
 *
 * Block description for '<S1>/Gain':
 * This block references an AUTOSAR calibration parameter, which is
 * accessed using the AUTOSAR Rte_Calprm function signature.
 */
rtwdemo_autosar_counter_B.Gain = Rte_Prm_rCounter_K() *
  Rte_DRead_Input_Input();
...
}
```

## AUTOSAR ModeSenderPorts and ModeSwitchPoints for application mode management

AUTOSAR mode-switch (M-S) communication relies on a mode manager and connected mode users. The mode manager is an authoritative source for software components to query the current mode and to receive notification when the mode changes. A mode manager can be provided by AUTOSAR Basic Software (BSW) or implemented as an AUTOSAR software component. A mode manager implemented as a software component is called an application mode manager. A software component that queries the mode manager and receives notifications of mode changes is a mode user.



R2016b enhances Simulink modeling of AUTOSAR M-S communication by adding the ability to model application mode manager components, including AUTOSAR mode sender ports (as defined in AUTOSAR Release 4). Mode sender ports output a mode switch to connected mode user components. For example, here is an application mode manager, modeled in Simulink, that uses a mode sender port to output the current value of EngineMode.

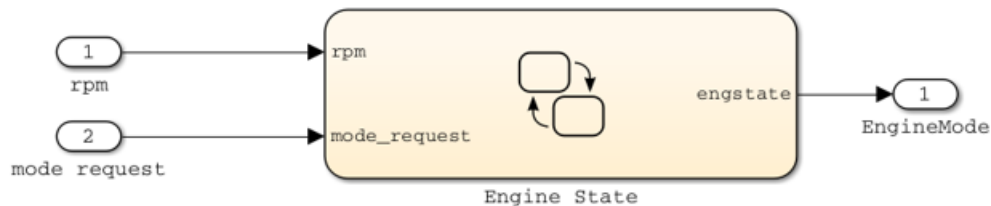

For more information, see Mode-Switch Interface and Configure AUTOSAR Mode-Switch Communication.

## AUTOSAR reference element definitions for sharing among components and services

R2016b supports a new workflow for importing external AUTOSAR element definitions, defined in `arxml` files, for sharing among multiple AUTOSAR components and services. Benefits of sharing and reusing AUTOSAR element definitions include lower risk of definition conflicts and easier code integration. You can manage shared definitions in a centralized way.

Suppose that you have a large number of AUTOSAR software components that use similar packageable AUTOSAR elements in similar ways. You can define sets of *reference elements* in `arxml` files, and your software components can share them on a read-only basis. Each software component can import the element definitions it requires and reference them. When you build the model, exported `arxml` code contains references to the shared elements, but not their definitions. Their definitions remain in the reference element `arxml` source files.

If definitions of reference elements change, you modify them in the `arxml` files, and then import the updated definitions into the affected software components.

AUTOSAR elements that are supported for reference use in Simulink include:

- CompuMethod, Unit, and PhysicalDimension
- ImplementationDataType and SwBaseType
- SwSystemConst, SwSystemConstValueSet, and PredefinedVariant
- SwRecordLayout
- SwAddrMethod

For more information, see Import or Update Shared AUTOSAR Reference Element Definitions.

## ERT Target Code Generation: Remove unreachable reset and disable functions to reduce dead code

In some model referencing contexts for ERT targets, generating code models can contain `reset` and `disable` functions that are dead code. You can use two new configuration parameters to remove the generated `disable` and `reset` functions that cannot be reached from anywhere in the generated code. Avoiding dead code is essential in safety-critical applications.

The new configuration parameters are:

- Remove reset function (`RemoveResetFunction`)
- Remove disable function (`RemoveDisableFunction`)

See Remove Reset and Disable Functions from the Generated Code.

## Compatibility Considerations

The **Remove reset function** configuration parameter replaces the **Optimize initialization code for model reference** parameter.

- In R2016b, if you load a legacy model from an earlier release that has the **Optimize initialization code for model reference** parameter set, the new **Remove reset function** parameter is set to produce the same behavior as the **Optimize initialization code for model reference** parameter produced.
- If you save a model created in R2016b to an earlier release, the **Optimize initialization code for model reference** parameter is updated appropriately. The

model saved to a previous version reflects the behavior that was specified with the **Remove reset function** parameter.

## Conditional compile time check for imported macros with ImportedDefine custom storage class

In R2016a, for a model that contained variant blocks and a `Simulink.Parameter` with an `ImportedDefine` custom storage class, the compile-time check for the `Simulink.Parameter` was unconditional. If the `Simulink.Parameter` was undefined, there was an error even if the `Simulink.Parameter` was in the inactive variant.

In R2016b, the compile-time check is conditional, so the error occurs only if the `Simulink.Parameter` is undefined and in the active variant.

Suppose that a model contains two Variant Subsystem blocks, `Variant A` and `Variant B`. `Variant B` contains a Constant block in which the **Constant value** parameter is the `Simulink.Parameter` `myvar`. `myvar` has an `ImportedDefine` custom storage class.

In R2016a, the `model.h` file contained this code:

```
#ifndef myvar
#error The variable for the parameter "myvar" is not defined
#endif
```

The code for `myvar` was not conditionally compiled. If you did not define `myvar` in a user-provided header file, there was an error.

In R2016b, the `model.h` file contains this code:

```
#if Variant B
#ifndef myvar
#error The variable for the parameter "myvar" is not defined
#endif
```

There is an error only if `myvar` is undefined and `Variant B` is the active variant because the code for `myvar` is conditionally compiled. See [Variant Systems](#).

## Additional guarding of global data for variant systems

In R2016a, for models that contained Variant Source or Variant Sink blocks, preprocessor conditionals surrounded global variable declarations for root inports and root outports.

In R2016b, preprocessor conditionals also surround most global variable declarations for Dwork vectors, signals, and states. The inclusion of preprocessor conditionals around these global variable declarations conserves RAM because the code is not compiled unless these global variables are part of the active variant.

For example, the model `inline_variants_example` contains three Variant Source blocks. `Variant Source` is in the top model and in `Subsystem`. `Variant Source1` is in the top model. `Subsystem` contains a Unit Delay block and a signal with a **Signal Name** of `sig1`.

For `Variant Source`, if the `Simulink.Parameter V` equals 1, the top port is active. If `V` equals 2, the bottom port is active. For `Variant Source1`, if the `Simulink.Parameter W` equals 1, the top port is active. If `W` equals 2, the bottom port is active.

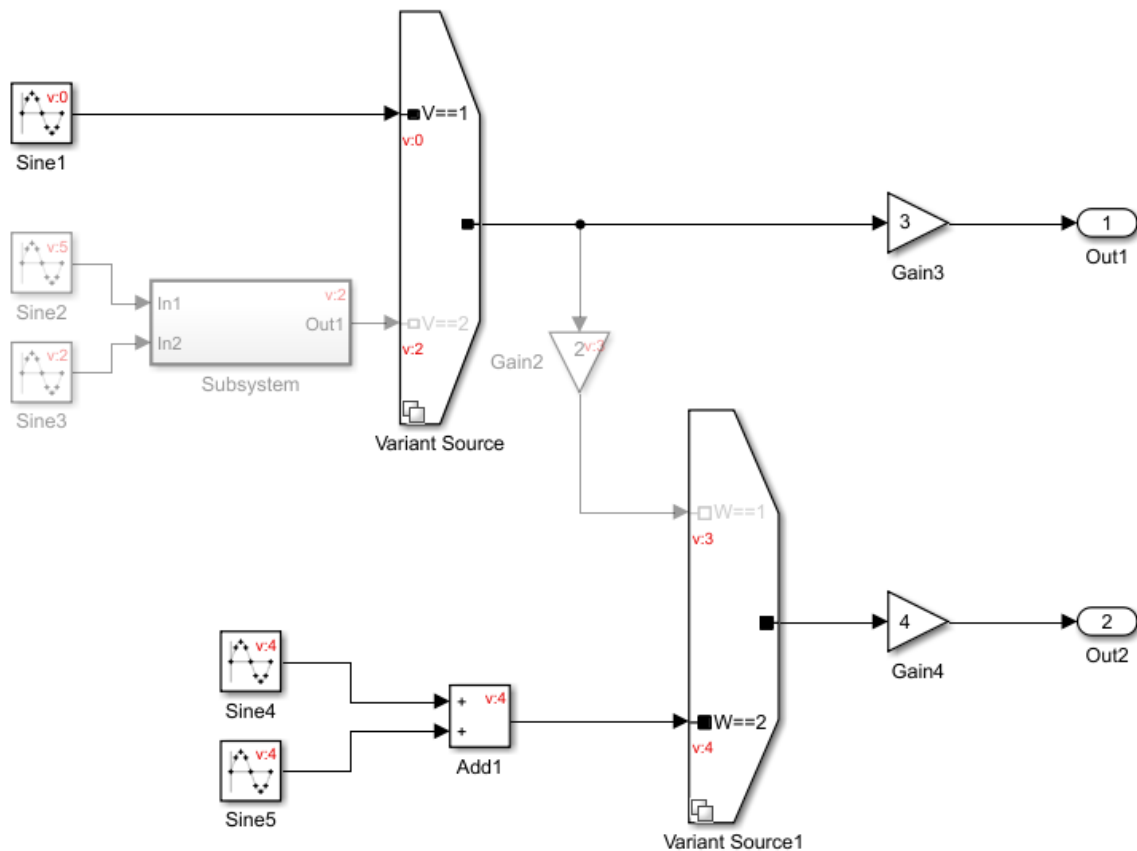

Copyright 2015 The MathWorks Inc.  
MathWorks Confidential

In R2016a, in the `inline_variants_example.h` file, for block signals and states, the code generator produced this code.

```

/* Block signals (auto storage) */
typedef struct {
    real_T VariantMerge_For_Variant_Source;
    real_T Sine3; /* '<Root>/Sine3' */
    real_T sig1; /* '<S1>/Unit Delay' */
} B_inline_variants_example_T;

```

```
/* Block states (auto storage) for system '<Root>' */
typedef struct {
    real_T delay1;                /* '<S1>/Unit Delay' */
    int32_T counter;              /* '<Root>/Sine1' */
    int32_T counter_f;           /* '<Root>/Sine4' */
    int32_T counter_e;          /* '<Root>/Sine5' */
    int32_T counter_fl;          /* '<Root>/Sine3' */
} DW_inline_variants_example_T;
```

Preprocessor conditionals do not surround the global variable declarations.

In R2016b, in the `inline_variants_example.h` file, the code generator produces this code.

```
/* Block signals (auto storage) */
typedef struct {
    real_T VariantMerge_For_Variant_Source;
    real_T Sine3;                /* '<Root>/Sine3' */

#if V == 2

    real_T sig1;                /* '<S1>/Unit Delay' */

#define B_INLINE_VARIANTS_EXAMPLE_T_VARIANT_EXISTS
#endif                          /* V == 2 */

} B_inline_variants_example_T;

/* Block states (auto storage) for system '<Root>' */
typedef struct {

#if V == 2

    real_T delay1;                /* '<S1>/Unit Delay' */

#define DW_INLINE_VARIANTS_EXAMPLE_T_VARIANT_EXISTS
#endif                          /* V == 2 */

    int32_T counter;              /* '<Root>/Sine1' */
    int32_T counter_f;           /* '<Root>/Sine4' */
    int32_T counter_e;          /* '<Root>/Sine5' */
    int32_T counter_fl;          /* '<Root>/Sine3' */
} DW_inline_variants_example_T;
```

For block signals and states, preprocessor conditionals do surround the global variable declarations. See Represent Variant Source and Sink Blocks in Generated Code.

## Data, Function, and File Definition

### **Simulink Function Code Interface: Configure generated C/C++ function interfaces for Simulink Function and Function Caller blocks**

With Embedded Coder, you can customize generated C/C++ function interfaces. Function code interface configuration supports easier integration of generated code with functions or function calls in external code and customizations for coding standards or design requirements.

R2016b extends function code interface configuration to Simulink Function and Function Caller blocks. By opening a dialog box from a selected Simulink Function or Function Caller block, you can customize the C/C++ function prototype generated for that block. Your changes for the selected block also update other corresponding Simulink Function and Function Caller blocks in the model. You can change the generated C/C++ function name, and the names, type qualifiers, and order of function arguments. Your changes do not graphically alter the model and do not affect the Simulink function prototype defined in the block.

For example, you can configure a Simulink function prototype  $y = f3(u)$  to generate a C/C++ function prototype such as `void function3(* y, const * u)`.



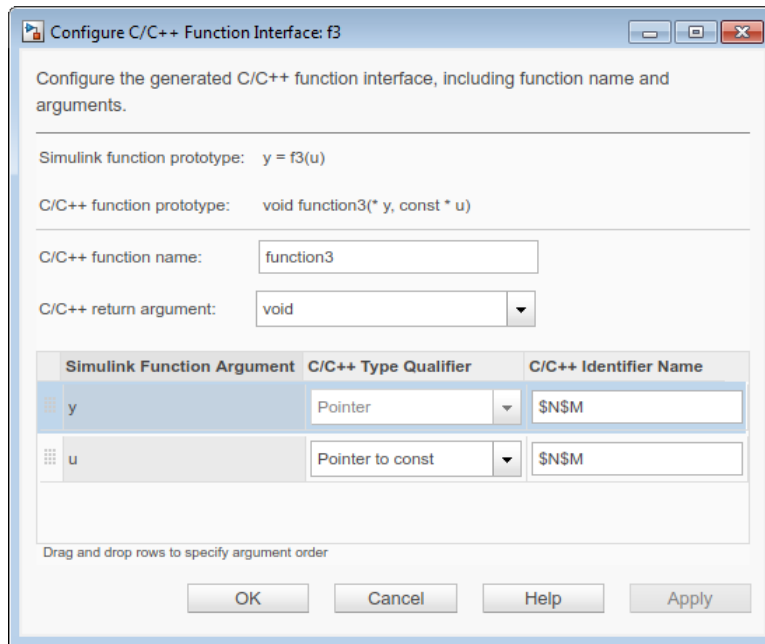

For more information, see [Configure Simulink Function Code Interface](#).

## ERT default value for configuration parameter ParameterTunabilityLossMsg

In R2016b, the default value for the configuration parameter **Diagnostics > Data Validity > Detect loss of tunability** (programmatic name `ParameterTunabilityLossMsg`) for ERT-based targets is `error`. When you use the configuration parameter **Code Generation > System target file** to switch to an ERT-based code generation target from a target that is not ERT-based, **Detect loss of tunability** is set to `error`. If necessary, you can then change the value of **Detect loss of tunability**.

## Compatibility Considerations

Your scripts that change code generation targets can unintentionally change the setting for **Detect loss of tunability**, causing unexpected errors during code generation.

## Code Generation

### Cross-Release Code Integration: Reuse code generated from earlier releases

Integrate R2016b generated code with existing:

- Shared code that is custom code or code that you generated from previous releases.
- Model code that you generated from previous releases (R2010a and later).

You avoid the cost of reverification because you reuse the existing code without modification.

You can use the `sharedCodeUpdate` function to collocate shared code from multiple source folders in an existing shared code folder. R2016b also provides the following configuration parameters on the **Configuration Parameters > All Parameters** tab:

- **Existing shared code** (`ExistingSharedCode`) — Specifies the folder that contains the shared code.
- **Use only existing shared code** (`UseOnlyExistingSharedCode`) — A diagnostic setting that determines whether the build process is permitted to generate new shared code that is not available from the specified folder.

You can use the `crossReleaseExport` and `crossReleaseImport` functions to integrate model code from previous releases when:

- The source models are single-rate, and set to generate nonreusable code with function prototype control (root-level `Inport` and `Outport` blocks are mapped to step function arguments).
- The model code has been produced by top-model and subsystem build processes.

Follow this workflow:

- 1 From a previous release, use the `crossReleaseExport` function to export model components. Add the function to the search path for that release with the following command:  

```
addpath(fullfile(matlabRootForR2016b, 'toolbox', 'coder', 'xrelexport'));
```
- 2 With the `crossReleaseImport` function, import components from previous releases via software-in-the-loop (SIL) or processor-in-the-loop (PIL) blocks.

### 3 Insert the SIL or PIL blocks into your R2016b model.

When you run a model simulation, the simulation runs the previous release code through the SIL or PIL blocks.

When you build your model, new code is not generated for the components represented by the SIL or PIL blocks. The model code calls code generated by a previous release.

For more information, see:

- Cross-Release Shared Code Reuse
- Cross-Release Code Integration

## **Compound Operation Code Replacement: Replace "Multiply Shift Right Arithmetic" and "Multiply Divide" in generated code with a single custom operation**

R2016b supports replacement of code for these compound operations with a single custom operation:

- Integer replacement of real, scalar multiplication followed by a shift right arithmetic operation (RTW\_OP\_MUL\_SRA)
- Integer replacement of real, scalar multiplication followed by a division operation (RTW\_OP\_MULDIV)

## **ARXML import/export and C code generation for latest AUTOSAR 4.2 and 3.2 standard revisions**

R2016b extends support of AUTOSAR schema versions 4.2 and 3.2 to include schema revisions 4.2.2 and 3.2.2. Embedded Coder supports the new schema revisions for import and export of arxml files and generation of AUTOSAR-compatible C code.

If you import schema 4.2.2 or 3.2.2 arxml code into Simulink, the arxml importer detects and uses the schema version and revision, and sets the schema version parameter in the model. For more information on schema import and export, see [Select an AUTOSAR Schema](#).

If you are developing an AUTOSAR software component based on AUTOSAR schema version 3.2, schema revision 3.2.2 allows you to include sender-receiver port end-to-end (E2E) protection, receiver port IsUpdated service, and port-based nonvolatile (NV) data communication in your component design.

---

**Note:** This support is available to R2015b and R2016a Embedded Coder customers by installing the latest AUTOSAR support package for your release:

- R2015b Embedded Coder Support Package for AUTOSAR Standard, Version 15.2.4 or later
  - R2016a Embedded Coder Support Package for AUTOSAR Standard, Version 16.1.1 or later
- 

## AUTOSAR code replacement library enhancements

R2016b improves the AUTOSAR code replacement library (CRL) by adding support for:

- Functions that perform multiplication followed by a shift right arithmetic operation.
- Arguments of type `struct` for the lookup table functions that perform prelookup and interpolation operations.

For more information, see [AUTOSAR Code Replacement Library](#).

## Static code metrics report for C++ code

In R2016b, for a Simulink model with the target language set to C++, you can generate a **Static Code Metrics Report**. For more information, see [Generate Static Code Metrics Report for Simulink Model and Static Code Metrics](#).

## Static code metrics data produced by Polyspace

In R2016b, for a Simulink model, Polyspace® produces the data in the Static Code Metrics Report. The report contains the same information types in R2016b as it contained in R2016a. For a model, in the **Function Information** section of the Static Code Metrics Report, there can be differences between the Stack Size and Complexity in R2016b and R2016a.

## Streamlined report pane for easier model configuration

In the Configuration Parameters dialog box, a streamlined **Code Generation > Report** pane displays only configuration parameters that you are most likely to use when configuring your model for code generation.

## Compatibility Considerations

Following are the configuration parameters on the **Code Generation > Report** pane that are now only available on the **All Parameters** tab.

- **Code-to-model**
- **Model-to-code**
- **Eliminated / virtual blocks**
- **Traceable Simulink blocks**
- **Traceable Stateflow blocks**
- **Traceable MATLAB blocks**
- **Summarize which blocks triggered code replacements**

## Improved traceability between model and code

In R2016b, these features enhance traceability between the model and generated code:

- Line-level traceability
- Highlighted code for multiple blocks or Stateflow objects

Previously, traceability between model and code depended on block comments in the generated code. If these comments were disabled, traceability was not available. In R2016b, Embedded Coder provides more precise model-to-code and code-to-model navigation with traceability to lines of code. Line-level traceability is enabled by default and is not dependent on block comments in the code.

From the code generation report, click a linked line of code to navigate to corresponding blocks in the model. From a block or blocks in your model, right-click the block and select **C/C++ Code > Navigate To C/C++ Code**. Highlighted lines of code in the code generation report correspond to your selected model blocks. Line-level traceability supports Simulink blocks, MATLAB function blocks, and Stateflow objects. The HTML traceability report and Microsoft<sup>®</sup> Excel<sup>®</sup> traceability matrix include line-level traceability information.

---

**Note:** Line-level traceability is not available for some TLC-generated code and for code in header files.

---

In R2016b, you can select multiple blocks or Stateflow objects for model-to-code navigation. To highlight code for multiple objects:

- 1 To select contiguous blocks to trace, click and drag the cursor over the contiguous blocks. Alternatively, **Shift** + click to select the individual blocks.
- 2 From the selected blocks, right-click the blocks and select **C/C++ Code > Navigate To C/C++ Code**. The code generation report highlights lines of code that correspond to the selected blocks.

## Code replacement enhancements

R2016b supports these code replacement enhancements:

- Integer replacement of real, scalar multiplication followed by a shift right arithmetic or division operation.
- When generating code for models that contain fixed-point calculations, improved integer code replacements for these saturating, real, scalar operations:
  - Addition, RTW\_OP\_ADD
  - Subtraction, RTW\_OP\_MINUS
  - Multiplication, RTW\_OP\_MUL
  - Division, RTW\_OP\_DIV
  - Data type conversion (cast), RTW\_OP\_CAST
- Improved detection of identity operations to avoid unnecessary replacements.

For more information, see [Code Replacement](#) and [Code Replacement Customization](#).

## **\$I** macro changed for argument names used as input and output

Previously, when you specified custom function argument names for a Simulink function by using the Subsystem method arguments parameter, for arguments that were input and output, the generated code inserted a **y** for the **\$I** macro. In R2016b, the generated code inserts a **uy**.

## Improved compliance with MISRA C:2012 Rules 10.1, 10.5, and 10.8

In R2016b, in the Configuration Parameters dialog box, on the **Code Generation > Code Style** tab, when you set the **Casting Modes** parameter to **Standards**

Compliant, for more modeling patterns, the code generator produces code that is compliant with the Essential Type Model: Rules 10.1–10.8. See MISRA C:2012 Directives and Rules.

### MISRA C:2012 Rule 10.1

In R2016b, for operations involving Prelookup blocks, the code generator can produce code that is compliant with MISRA C:2012 Rule 10.1. For example, in the model `misra1`, in the Prelookup block parameters dialog box, the **Value** parameter is a vector with 256 elements.

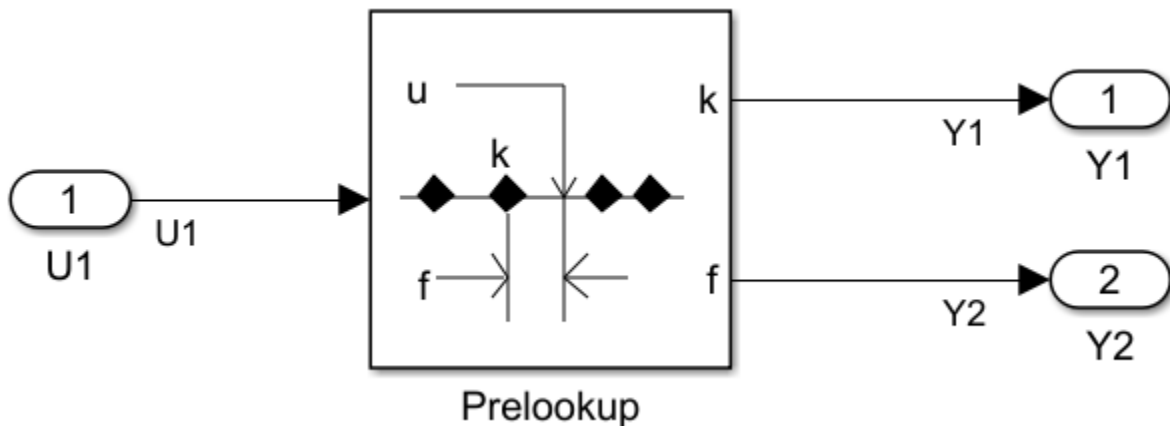

In R2016a, in the `misra1.c` file, for the Prelookup block, the code generator produced this code:

```
if (u < (((int32_T)bp[0U]) << 16)) {
    bpIndex = 0U;
    *fraction = 0U;
}
```

This code is not compliant with MISRA C:2012 Rule 10.1 because the left operand of the `<<` operator is a signed integer, which is an inappropriate essential type.

In R2016b, in the `misra1.c` file, for the Prelookup block, the code generator produces this code:

```
if (u < (((int32_T)((uint32_T)(((uint32_T)bp[0U]) << 16)))) {
    bpIndex = 0U;
```

```

    *fraction = 0U;
}

```

This code is compliant with MISRA C:2012 Rule 10.1 because the left operand is cast to an unsigned type.

### MISRA C:2012 Rules 10.5 and 10.8

In R2016b, for more modeling patterns containing type conversions between different essential type categories, the code generator produces code that is compliant with MISRA C:2012 Rules 10.5 and 10.8. For example, in the model `misra2`, signals with data types Boolean and unsigned integer feed into a Sum block. The Sum block outputs a signal with a data type of unsigned integer.

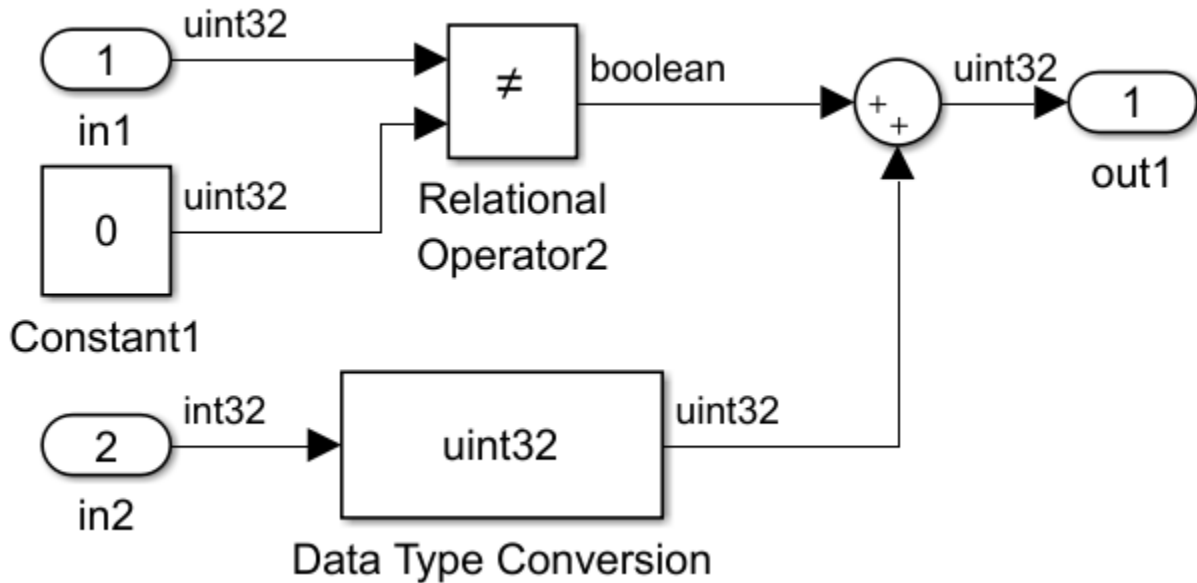

In R2016a, in the `misra2.c` file, the code generator produced this code:

```

misra2_Y.out1 = ((uint32_T)(misra2_U.in1 != 0U)) + ((uint32_T)misra2_U.in2);

```

This code is not compliant with MISRA C:2012 Rules 10.5 and 10.8 because a Boolean, which is the output of the relational operator, is cast to an unsigned integer.

In R2016b, in the `misra2.c` file, the code generator produces this code:



```
misra2_Y.out1 = ((uint32_T)((misra2_U.in1 != 0U) ? 1 : 0)) + ((uint32_T)
    misra2_U.in2);
```

This code is compliant with MISRA C:2012 Rules 10.5 and 10.8 because the ternary operator prevents a cast from a Boolean to an unsigned integer.

## Improved compliance with MISRA AC AGC Rule 12.6

In R2016a, for Variant Subsystem, Variant Source, and Variant Sink blocks, the preprocessor conditional that checked for only one active variant was not compliant with MISRA AC AGC Rule 12.6. In R2016b, this preprocessor conditional check is compliant with this rule. MISRA AC AGC Rule 12.6 states

Operands of logical operators (&&, || and !) should be effectively Boolean. Expressions that are effectively Boolean should not be used as operands to operators other than (&&, ||, or !).

For example, the model `misra_check` contains two Variant Subsystems, `Variant1` and `Variant2`. For `Variant Subsystem`, if the `Simulink.Parameter VC` equals 1, `Variant1` is active. If `VC` equals 2, `Variant2` is active. For `Variant Subsystem1`, if the `Simulink.Variant V1` evaluates to true, `Variant1` is active. If the `Simulink.Variant V2` evaluates to true, `Variant2` is active.

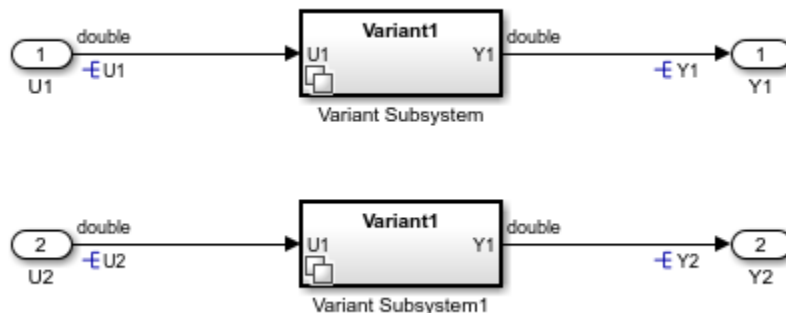

In R2016a, in the `preprocessor_check_types.h` file, the preprocessor conditionals that checked for just one active variant per subsystem were

```
/* Exactly one variant for '<Root>/Variant Subsystem' should be active */
```

```
#if (VC == 1) + (VC == 2) != 1
#error Exactly one variant for '<Root>/Variant Subsystem' should be active
#endif

/* Exactly one variant for '<Root>/Variant Subsystem1' should be active */
#if (V1) + (V2) != 1
#error Exactly one variant for '<Root>/Variant Subsystem1' should be active
#endif
#endif
```

According to the second sentence of Rule 12.6, VC==1 and VC==2 and V1 and V2 should not be added together because they are effectively Boolean expressions.

In R2016b, in the `preprocessor_check_types.h` file, the preprocessor conditionals that check for one active variant per subsystem are

```
/* Exactly one variant for '<Root>/Variant Subsystem' should be active */
#if ((VC == 1) ? 1 : 0) + ((VC == 2) ? 1 : 0) != 1
#error Exactly one variant for '<Root>/Variant Subsystem' should be active
#endif

/* Exactly one variant for '<Root>/Variant Subsystem1' should be active */
#if ((V1) ? 1 : 0) + ((V2) ? 1 : 0) != 1
#error Exactly one variant for '<Root>/Variant Subsystem1' should be active
#endif
#endif
```

The conditional checks contain ternary Boolean operators that do not violate MISRA Rule 12.6. See MISRA C:2004 and MISRA AC AGC Coding Rules.

## Use default installation folder on Windows system with ReFS file system

In previous releases, on Windows systems, the code generator relied on 8.3 name or short file name generation to operate from the default installation folder (for example, C:\Program Files\MATLAB\R2015b).

The Windows ReFS (Resilient File System) does not permit 8.3 name or short file name generation. ReFS differs from Windows NTFS (New Technology File System), which—by default—provides short file name support.

To support the default MATLAB installation folder on Windows systems with the ReFS file system or when NTFS short file name support is disabled, the code generation software maps a drive corresponding to the MATLAB installation folder.

For more information, see [Enable Build Process for Folder Names with Spaces](#).

## Deployment

### **Cortex-M7 Target Support Package: Generate code for STM32F746G-Discovery Board**

You can use the Embedded Coder Support Package for STMicroelectronics Discovery Boards to generate code on the Cortex-M7 based STM32F746G-Discovery board.

To build your model for the STM32F746G-Discovery board, you can use the following blocks from the support package library:

- Audio Input
- Audio Output
- Analog Input
- Digital Read
- Digital Write
- I2C Master Read
- I2C Master Write
- PWM Output
- SPI Master Transfer
- SPI Register Read
- SPI Register Write

For more information, see Embedded Coder Support Package for STMicroelectronics Discovery Boards.

### **Added Embedded Coder Support Package for ARM Cortex-R Processors**

You can use the *Embedded Coder Support Package for ARM Cortex-R Processors* to:

- Run executables with FreeRTOS on a Texas Instruments Hercules RM57Lx Launchpad, which uses a lockstep cached 330Mhz ARM Cortex-R5F based RM series MCU.
- Tune parameters on, and monitor data from, an executable running on the Texas Instruments Hercules RM57Lx Launchpad (External mode).

- Verify numeric accuracy and profile execution times using processor-in-the-loop (PIL) on the Texas Instruments Hercules RM57Lx Launchpad.
- Profile task and function execution times of executables running in real time on the Texas Instruments Hercules RM57Lx Launchpad.

To download and install this feature, perform the steps described in <http://www.mathworks.com/help/releases/R2016b/supportpkg/armcortexr/ug/install-support-for-arm-cortex-a-processors.html>.

For more information, see <http://www.mathworks.com/help/releases/R2016b/supportpkg/armcortexr/index.html>.

## Improved External mode over serial communication

The external mode in Embedded Coder Support Package for Texas Instruments C2000™ Processors feature is now improved with a faster serial communication protocol. The new protocol reduces data drop during data logging. With this change, increasing the baud rate also increases the data logging performance.

## New blocks added to TI's C2000 support package

You can use eCAP, eQEP, CLA, and DAC blocks on TI's C2000™ F2837xS, F2837xD, and F2807x processors.

Use the eCAP block to capture input pin transitions or configure auxiliary pulse width modulator.

Use the eQEP block to interface with a linear or rotary incremental encoder.

Use CLA Trigger block to run code on Control Law Accelerator (CLA) co-processor available on F2803x, F2806x, F2837xS, F2837xD, and F2807x processors.

Use the DAC block to convert digital data to analog signal.

## Change in name and the base product for the FRDM-K64F and the FRDM-KL25Z support packages

The base product for FRDM-K64F and FRDM-KL25Z support packages is changed from Embedded Coder to Simulink Coder. The two support package are now named as

Simulink Coder Support Package for NXP™ FRDM-K64F Board and Simulink Coder Support Package for NXP FRDM-KL25Z Board respectively. For more information, see Simulink Coder Target Support Packages: Generate code for NXP Freedom boards and STMicroelectronics Nucleo boards.

## **Support for TI's C5000 DSPs has been removed**

Embedded Coder support for TI's C5000 has been removed in R2016b. However, you can still generate code using Embedded Coder® by selecting TI's C5000 as the device vendor on the Hardware Implementation pane for ANSI-C. You can also create your own target optimizations using code replacement libraries. For more information, see [Optimize Generated Code By Developing and Using Code Replacement Libraries - Simulink®](#).

## **Support for TI's C6000 has been removed**

Embedded Coder support for TI C6000™ has been removed in R2016b. However, you can still generate code using Embedded Coder by selecting TI's C6000™ as the device vendor on the Hardware Implementation pane for ANSI-C. You can also create your own target optimizations using code replacement libraries. For more information, see [Optimize Generated Code By Developing and Using Code Replacement Libraries - Simulink®](#).

## **Support for Wind River VxWorks RTOS will be removed**

Embedded Coder support for Wind River VxWorks RTOS will be removed in a future release. You will still be able to use Embedded Coder for Wind River VxWorks RTOS, but will need to manually integrate the generated code with hand written scheduler and drivers.

## **Support for idelink\_ert.tlc will be removed**

Support for idelink\_ert.tlc will be removed in R2017a. C2000 processors will be supported only on ert.tlc workflow.

## Performance

### Data Reuse and Memory Reduction: Reuse global data for nonreusable subsystems and reduce data copies with user-specified buffers

#### Buffer reuse across nonreusable subsystems

In R2016b, for a model containing multiple nonreusable subsystems, the code generator can reuse a single global buffer. In the subsystem block parameters dialog box, on the **Code Generation** tab, a nonreusable subsystem has the **Function packaging** parameter set to **Nonreusable function**. The **Function interface** parameter is set to **void\_void**. This optimization decreases data copies and memory consumption and increases code execution speed.

For example, the model `rtwdemo_automatic_global_reuse` contains four nonreusable subsystems. The inputs to each subsystem are arrays of size 256.

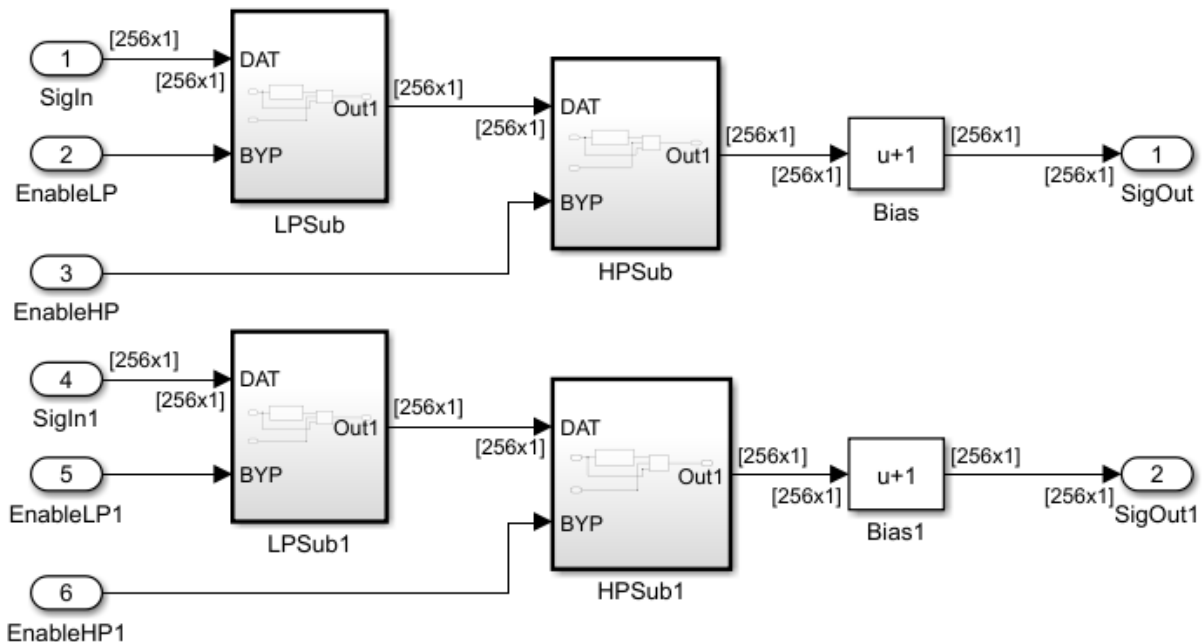

In R2016a, the `rtwdemo_automatic_global_reuse.h` file contained this code:

```
/* Block signals and states (auto storage) for system '<Root>' */
typedef struct {
    DW_LowpassFilter LowpassFilter_pn; /* '<S4>/Lowpass Filter' */
    DW_LowpassFilter LowpassFilter_p; /* '<S3>/Lowpass Filter' */
    DW_HighpassFilter HighpassFilter_pn; /* '<S2>/Highpass Filter' */
    DW_HighpassFilter HighpassFilter_p; /* '<S1>/Highpass Filter' */
    real_T Switch[256]; /* '<S4>/Switch' */
    real_T Switch_i[256]; /* '<S3>/Switch' */
    real_T Switch_k[256]; /* '<S2>/Switch' */
    real_T Switch_f[256]; /* '<S1>/Switch' */
} DW;
```

For each nonreusable subsystem, the global structure DW contained an array. The array names were `Switch`, `Switch_i`, `Switch_k`, and `Switch_f`.

In R2016b, the `rtwdemo_automatic_global_reuse.h` file contains this code:

```
/* Block signals and states (auto storage) for system '<Root>' */
typedef struct {
    DW_LowpassFilter LowpassFilter_pn; /* '<S4>/Lowpass Filter' */
    DW_LowpassFilter LowpassFilter_p; /* '<S3>/Lowpass Filter' */
    DW_HighpassFilter HighpassFilter_pn; /* '<S2>/Highpass Filter' */
    DW_HighpassFilter HighpassFilter_p; /* '<S1>/Highpass Filter' */
    real_T Switch[256]; /* '<S1>/Switch' */
} DW;
```

The global structure DW contains one array `Switch` for buffer reuse. Each nonreusable subsystem uses this array.

### Buffer reuse for multiple signals in a path

For blocks and subsystems that form a path, if the input and output signals to these blocks and subsystems have the same reusable storage class specification, the code generator tries to reuse the signals in the generated code. This optimization decreases data copies and memory consumption and increases code execution speed.

For user-specified buffer reuse, blocks that modify a signal specified for reuse must execute before blocks that use the original signal value. In R2016a, sometimes the code generator changed the block operation order so that buffer reuse occurred.

In R2016b, the code generator performs better reordering of block operations, so that more instances of user-specified buffer reuse can occur. For example, in the model `rtwdemo_reusable_csc_scheduling`, the `Simulink.Signal` reuse is for buffer reuse. The four subsystems have nonreusable function packaging.



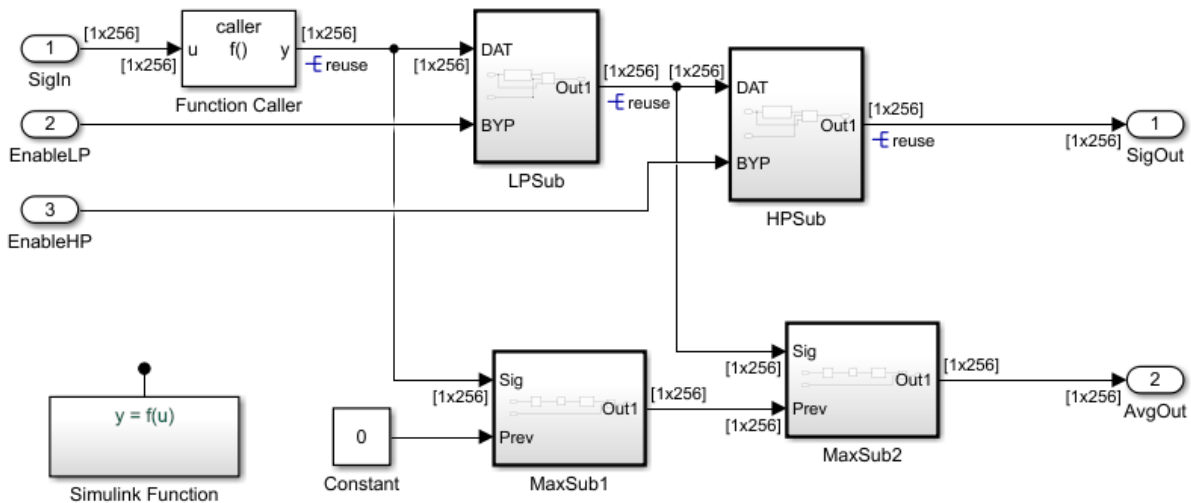

In R2016a, the `rtwdemo_reusable_csc_scheduling.c` file contained this code.

```

real_T reuse_1[256];
real_T reuse_0[256];
real_T reuse[256];
...
void rtwdemo_reusable_csc_scheduling_step(void)
{
    real_T rtb_MinMax_d[256];
    f(rtU.SigIn, reuse_1);
    LPSub();
    HPSub();
    MaxSub1(reuse_1, 0.0, rtb_MinMax_d);
    MaxSub2(reuse_0, rtb_MinMax_d, rtY.SigOut1);
}

```

For the `Simulink.Signal reuse`, there were three global variables: `reuse`, `reuse_0`, and `reuse_1`. The generated code could not use the same global variable in the four functions. `LPSub` and `HPSub` modified the signal value before `MaxSub1` and `MaxSub2` used it, and `MaxSub1` and `MaxSub2` had to use the original signal value.

In R2016b, the `rtwdemo_reusable_csc_scheduling.c` file contains this code:

```

real_T reuse[256];

```

```
...  
void rtwdemo_reusable_csc_scheduling_step(void)  
{  
    f(rtU.SigIn, (&(reuse[0])));  
    MaxSub1();  
    LPSub();  
    MaxSub2();  
    HPSub();  
}
```

For the `Simulink.Signal` reuse, there is one global variable `reuse`. The code generator can reuse this variable because calls to functions `MaxSub1` and `MaxSub2` happen before calls to functions `LPSub` and `HPSub`, respectively.

For more information, see [Specify Buffer Reuse for Multiple Signals in a Path](#).

## **Code Optimizations: Generate more efficient code with select-assign-iterator pattern and matrix padding operations**

In R2016b, for iterative select assignment modeling patterns and matrix padding operations, there are buffer reductions in the generated code. This optimization reduces memory usage and increases code execution speed. Iterative select-assignment modeling patterns and matrix padding operations are useful in image processing.

### **Data copy reduction for select-assign-iterator modeling pattern**

In R2016a, for a model that iteratively selects values from an input signal and assigns them to an output signal, there was an extra buffer in the generated code. In R2016b, the code generator eliminates this buffer.

For example, the `rtwdemo_optimize_nestedloops` model contains two select-assignment modeling patterns. One pattern is in the subsystem `MyFilter`. The other pattern is in the subsystem `ALGORITHM`, which is nested in `MyFilter`. Both subsystems contain a `for` Iterator block, a `Selector` block, and an `Assignment` block.

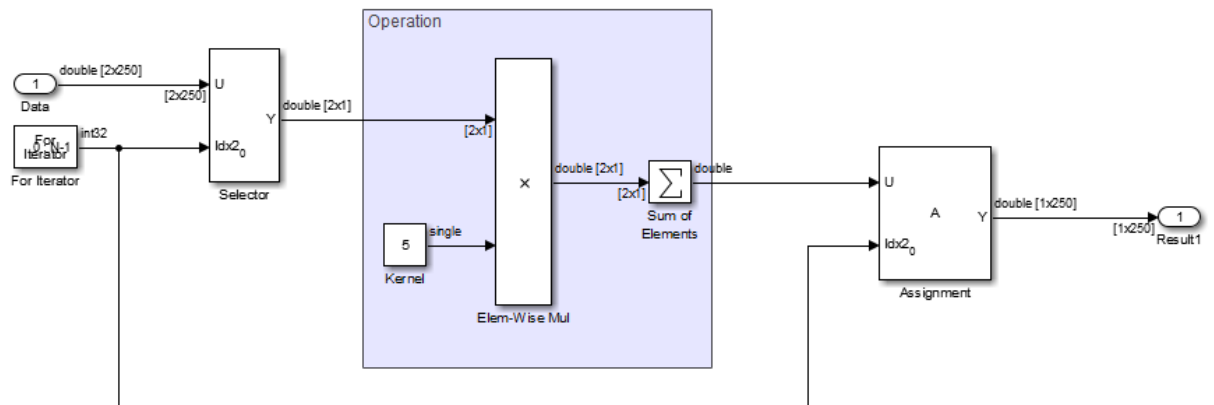
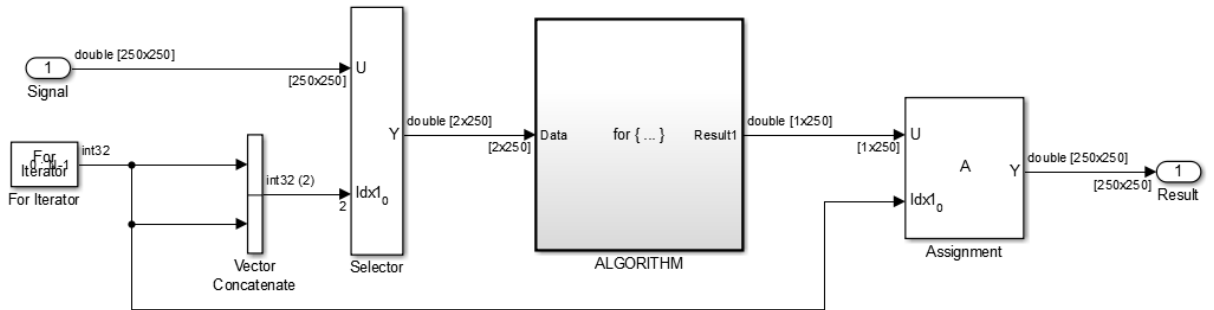

In R2016a, the code generator produced this code.

```
void rtwdemo_optimize_nestedloops_step(void)
{
    int32_T s1_iter;
    real_T rtb_Selector[500];
    int32_T s2_iter;
    for (s1_iter = 0; s1_iter < 250; s1_iter++) {
        for (s2_iter = 0; s2_iter < 250; s2_iter++) {
            rtb_Selector[s2_iter << 1] = rtwdemo_optimize_nestedloops_U.In1[250 *
                s2_iter + s1_iter];
            rtb_Selector[1 + (s2_iter << 1)] = rtwdemo_optimize_nestedloops_U.In1[250 *
                s2_iter + s1_iter];
            rtwdemo_optimize_nestedloops_Y.Out1[s1_iter + 250 * s2_iter] =
                rtb_Selector[(s2_iter << 1) + 1] * 5.0 + rtb_Selector[s2_iter << 1] *
                5.0;
        }
    }
}
```

The generated code contains the buffer `rtb_Selector[500]`.

In R2016b, the code generator produces this code.

```
void rtwdemo_optimize_nestedloops_step(void)
{
    int32_T s1_iter;
    int32_T s2_iter;
    for (s1_iter = 0; s1_iter < 250; s1_iter++) {
        for (s2_iter = 0; s2_iter < 250; s2_iter++) {
            rtwdemo_optimize_nestedloops_Y.Out1[s1_iter + 250 * s2_iter] =
                rtwdemo_optimize_nestedloops_U.In1[250 * s2_iter + s1_iter] * 5.0 +
                rtwdemo_optimize_nestedloops_U.In1[250 * s2_iter + s1_iter] * 5.0;
        }
    }
}
```

The generated code does not contain the `rtb_Selector[500]` buffer or the associated data copies.

### **Data copy reduction for matrix padding operations**

In R2016a, for a model that uses Matrix Concatenate blocks to add rows and columns to a multidimensional input signal, there was an extra buffer in the generated code. In R2016b, the code generator eliminates this buffer.

For example, in the model `pattern_grow_matrix`, the Vertical Matrix Concatenate block adds a row of 250 zeros and the Horizontal Matrix Concatenate blocks adds a column of 250 zeros to a multidimensional input signal.

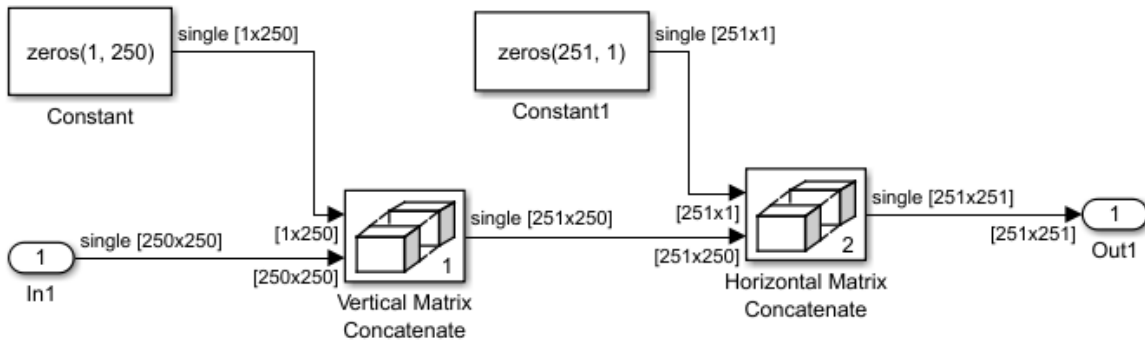

In R2016a, the code generator produced this code.

```

/* Model step function */
void pattern_grow_matrix_step(void)
{
    int32_T i;

    /* SignalConversion: '<Root>/ConcatBufferAtHorizontal Matrix ConcatenateIn1' */
    memset(&Y.Out1[0], 0, 251U * sizeof(real32_T));

    /* Concatenate: '<Root>/Vertical Matrix Concatenate' incorporates:
     * Constant: '<Root>/Constant'
     * Inport: '<Root>/In1'
     */
    for (i = 0; i < 250; i++) {
        B.fv0[251 * i] = 0.0F;
    }

    for (i = 0; i < 250; i++) {
        memcpy(&B.fv0[i * 251 + 1], &U.In1[i * 250], 250U * sizeof(real32_T));
    }

    memcpy(&Y.Out1[251], &B.fv0[0], 62750U * sizeof(real32_T));

    /* End of Concatenate: '<Root>/Vertical Matrix Concatenate' */
}

```

The code contained the buffer `B.fv0`.

In R2016b, the code generator produces this code.

```
/* Model step function */
void pattern_grow_matrix_step(void)
{
    int32_T i;

    /* SignalConversion: '<Root>/ConcatBufferAtHorizontal Matrix ConcatenateIn1' */
    memset(&Y.Out1[0], 0, 251U * sizeof(real32_T));

    /* Concatenate: '<Root>/Vertical Matrix Concatenate' incorporates:
     * Constant: '<Root>/Constant'
     * Inport: '<Roo>/In1'
     */
    for (i = 0; i < 250; i++) {
        Y.Out1[i * 251 + 251] = 0.0F;
    }

    for (i = 0; i < 250; i++) {
        memcpy(&Y.Out1[i * 251 + 252], &U.In1[i * 250], 250U * sizeof(real32_T));
    }

    /* End of Concatenate: '<Root>/Vertical Matrix Concatenate' */
}
```

The buffer, `B.fv0`, and the extra `memcpy` to `B.fv0` are not in the generated code.

## Display of code execution times for model component

R2016b provides improved viewing and analysis of code execution-time measurements that software-in-the-loop (SIL) or processor-in-the-loop (PIL) simulations produce. For example, at the end of a top-model SIL or PIL simulation, you can view execution-time metrics in a display window:

- For execution-time metrics from the top-level tasks, click the blue Simulink Editor background.
- For execution-time metrics from a profiled block, click the blue block.

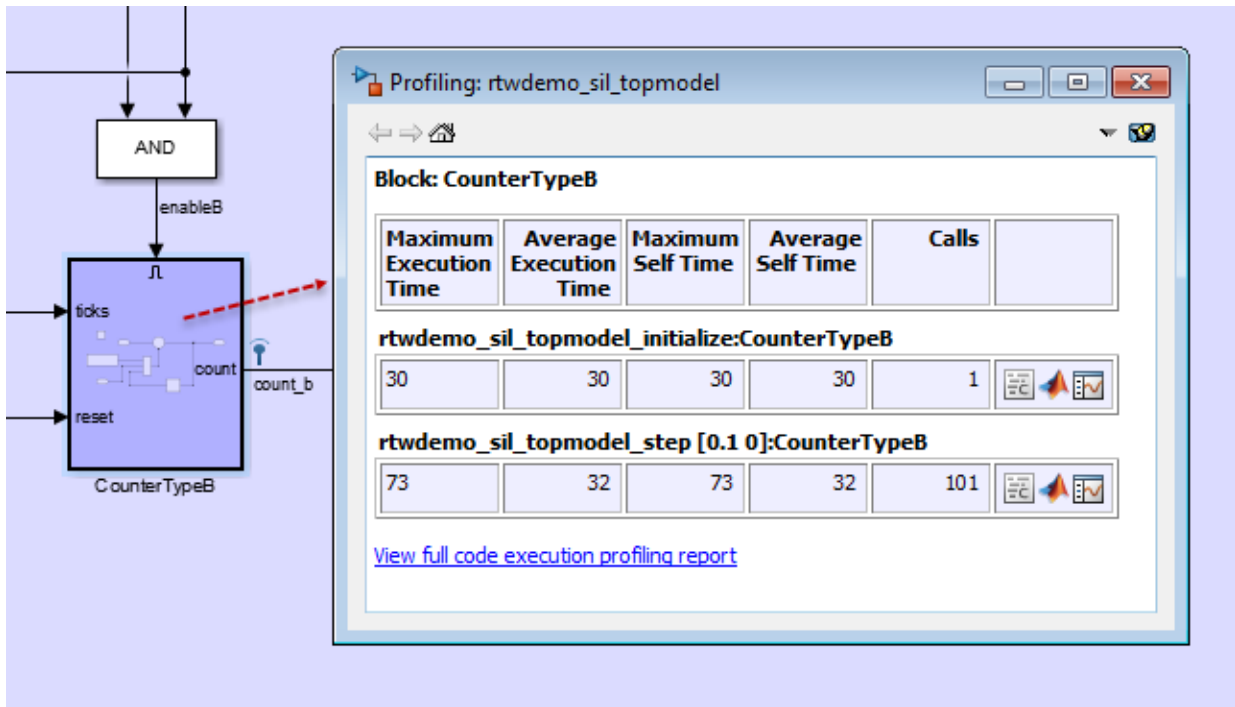

The display window also provides access to:

- The complete profiling report, which provides execution-time metrics for profiled code sections.
- The profiled code section in the code generation report.
- The Simulation Data Inspector, which enables you to plot and compare execution-time measurements for the profiled code section.

For more information, see [View and Compare Code Execution Times](#).

## More efficient code for array element assignments

In R2016a, for a model that contained a Product block that performed matrix multiplication, the code generator assigned values to the product matrix one column at a time. In the generated code, the array element assignments occurred out of order.

In R2016b, the code generator performs a loop exchange, so that these assignments occur one row at time. During a loop exchange, the code generator switches the order of iteration variables. In the generated code, the array element assignments occur in contiguous order.

When array element assignments occur in contiguous order, the CPU stores and accesses data in continuous memory. This optimization increases code execution speed because it improves cache efficiency.

For example, in the `matrix_multiply` model, the Product block processes the input vectors as matrices.

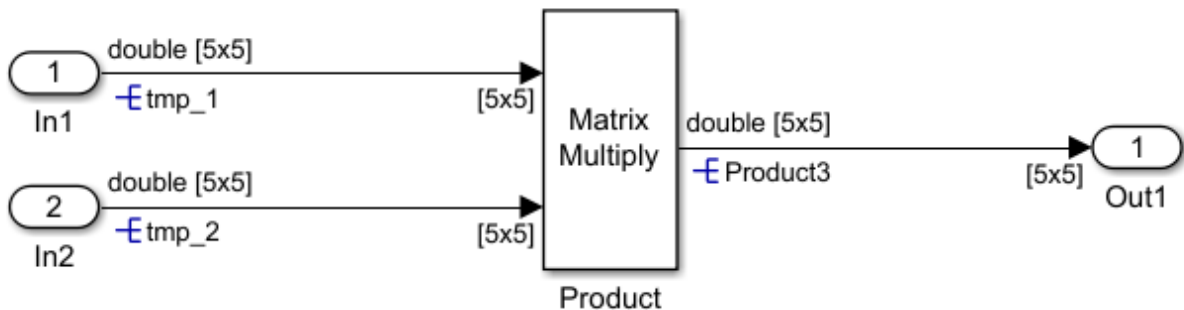

In R2016a, the code generator produced this code.

```

/* Product: '<Root>/Product' incorporates:
 * Inport: '<Root>/In1'
 * Inport: '<Root>/In2'
 */
for (i = 0; i < 5; i++) {
  for (i_0 = 0; i_0 < 5; i_0++) {
    matrix_multiply_B.Product3[i + 5 * i_0] = 0.0;
    for (i_1 = 0; i_1 < 5; i_1++) {
      matrix_multiply_B.Product3[i + 5 * i_0] += tmp_1[5 * i_1 + i] * tmp_2[5 *
        i_0 + i_1];
    }
  }
}

/* End of Product: '<Root>/Product' */
  
```



In the `matrix_multiply_step` function, element assignments to the array `matrix_multiply.Product3` occur in intervals of 5 (that is, one column at a time).

In R2016b, the code generator produces this code.

```

/* Product: '<Root>/Product' incorporates:
 * Inport: '<Root>/In1'
 * Inport: '<Root>/In2'
 */
for (i_0 = 0; i_0 < 5; i_0++) {
    for (i = 0; i < 5; i++) {
        matrix_multiply_B.Product3[i + 5 * i_0] = 0.0;
        for (i_1 = 0; i_1 < 5; i_1++) {
            matrix_multiply_B.Product3[i + 5 * i_0] += tmp_1[5 * i_1 + i] * tmp_2[5 *
                i_0 + i_1];
        }
    }
}

/* End of Product: '<Root>/Product' */

```

In the `matrix_multiply_step` function, element assignments to the array `matrix_multiply_B.Product3` occur in contiguous order (that is, one row at a time). The assignments occur in contiguous order because the code generator interchanges the iteration variables `i_0` and `i`. In R2016a, `i_0` is the iteration variable for the inner `for` loop, and `i` is the iteration variable for the outer `for` loop. In R2016b, `i_0` is the iteration variable for the outer `for` loop, and `i` is the iteration variable for the inner `for` loop.

## Loop fusion for nested for loops

In R2016a, for a model that used a Concatenate block to concatenate input signals into a continuous multidimensional signal, the generated code contained separate nested `for` loops for each signal. In R2016b, the code generator combines these `for` loops. This optimization conserves ROM consumption and increases code execution speed.

For example, in the model `loop_fusion`, the Vertical Matrix Concatenate block concatenates three signals that each have dimensions 3x4 into one signal with dimensions 9x4.

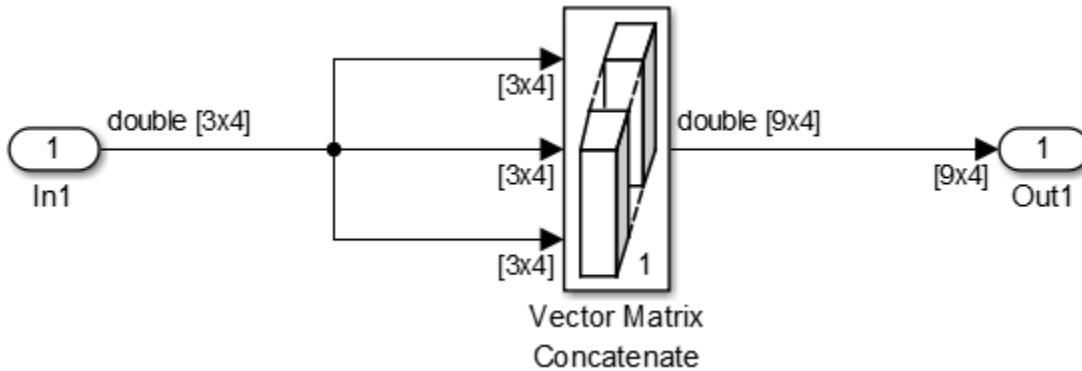

In R2016a, the code generator produced this code.

```
void loop_fusion_step(void)
{
    int32_T i;
    int32_T i_0;
    for (i = 0; i < 4; i++) {
        for (i_0 = 0; i_0 < 3; i_0++) {
            loop_fusion_Y.Out1[i_0 + 9 * i] = loop_fusion_U.In1[3 * i + i_0];
        }
    }

    for (i = 0; i < 4; i++) {
        for (i_0 = 0; i_0 < 3; i_0++) {
            loop_fusion_Y.Out1[(i_0 + 9 * i) + 3] = loop_fusion_U.In1[3 * i + i_0];
        }
    }

    for (i = 0; i < 4; i++) {
        for (i_0 = 0; i_0 < 3; i_0++) {
            loop_fusion_Y.Out1[(i_0 + 9 * i) + 6] = loop_fusion_U.In1[3 * i + i_0];
        }
    }
}
```

There are three nested for loops.

In R2016b, the code generator produces this code.

```
void loop_fusion_step(void)
```

```
{
  int32_T i;
  int32_T i_0;
  for (i_0 = 0; i_0 < 4; i_0++) {
    for (i = 0; i < 3; i++) {
      loop_fusion_Y.Out1[i + 9 * i_0] = loop_fusion_U.In1[3 * i_0 + i];
      loop_fusion_Y.Out1[(i + 9 * i_0) + 3] = loop_fusion_U.In1[3 * i_0 + i];
      loop_fusion_Y.Out1[(i + 9 * i_0) + 6] = loop_fusion_U.In1[3 * i_0 + i];
    }
  }
}
```

There is one nested `for` loop.

## More efficient initialization code for root-level inports

### Loop fusion in `model_initialize` function

In R2016a, the code generator did not fuse `for` loops that initialized data for root-level inports.

In R2016b, the code generator can fuse `for` loops that have the same upper bound value.

For example, in `loopfusionex`, for each Inport block, the **Port dimensions** parameter is `[50 47]`.

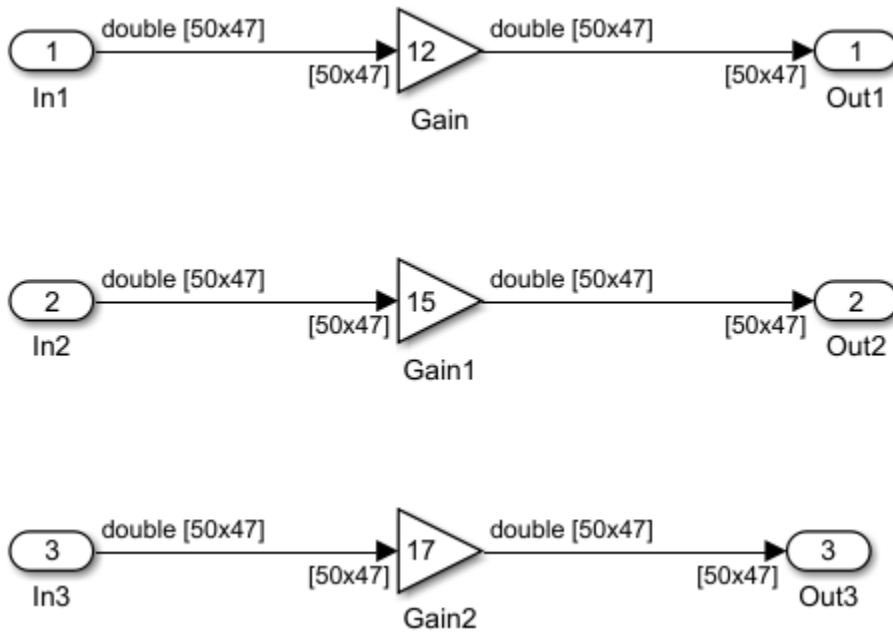

In R2016a, in the `loopfusionex_initialize` function, the code generator produced this code.

```

/* external inputs */
{
    int32_T i;
    for (i = 0; i < 2350; i++) {
        loopfusionex_U.In1[i] = 0.0;
    }
}

{
    int32_T i;
    for (i = 0; i < 2350; i++) {
        loopfusionex_U.In2[i] = 0.0;
    }
}

{
    int32_T i;
    for (i = 0; i < 2350; i++) {

```

```

        loopfusionex_U.In3[i] = 0.0;
    }
}

```

For each Inport block, the generated code contained a separate `for` loop. The code generator generated code that initialized root inports to zero because in the Configuration Parameters dialog box, on the **Optimization** pane, the **Remove root level I/O zero initialization** parameter is not selected.

In R2016b, the code generator produces this code.

```

/* external inputs */
{
    int32_T i;
    for (i = 0; i < 2350; i++) {
        loopfusionex_U.In1[i] = 0.0;
        loopfusionex_U.In2[i] = 0.0;
        loopfusionex_U.In3[i] = 0.0;
    }
}

```

The generated code contains one `for` loop to initialize data for the three root-level inports.

### One iteration variable for multiple `for` loops

In R2016a, in the `model_initialize` function, for `for` loops that initialized data for root-level Inport blocks, there was an iteration variable for each `for` loop.

In R2016b, for `for` loops that initialize data for root-level Inport blocks, there is one iteration variable for these `for` loops.

For example, in `for_loop_iterator`, for In1, In2, and In3, the **Port dimension** parameter is [50 47], [20 10], and 20, respectively. In the Configuration Parameters dialog box, on the **Optimization** pane, the **Remove root level I/O zero initialization** parameter is not selected.

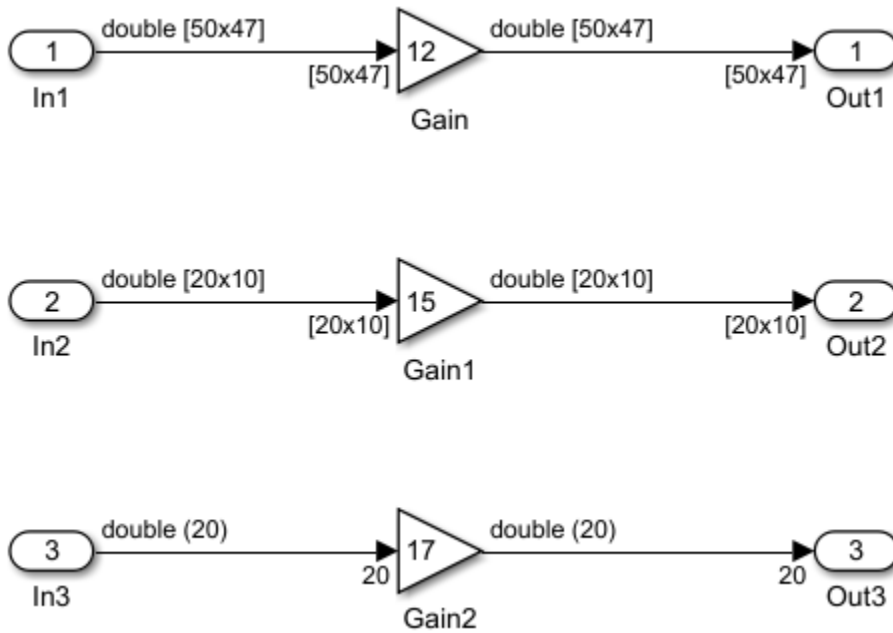

In R2016a, in the `for_loop_iterator_initialize` function, the code generator produced this code:

```
/* external inputs */
{
    int32_T i;
    for (i = 0; i < 2350; i++) {
        for_loop_iterator_U.In1[i] = 0.0;
    }
}

{
    int32_T i;
    for (i = 0; i < 200; i++) {
        for_loop_iterator_U.In2[i] = 0.0;
    }
}

{
    int32_T i;
    for (i = 0; i < 20; i++) {
```

```

        for_loop_iterator_U.In3[i] = 0.0;
    }
}

```

The iteration variable `i` was declared three times—once for each `for` loop.

In R2016b, in the `for_loop_iterator_initialize` function, the code generator produces this code:

```

/* external inputs */
{
    int32_T i;
    for (i = 0; i < 2350; i++) {
        for_loop_iterator_U.In1[i] = 0.0;
    }

    for (i = 0; i < 200; i++) {
        for_loop_iterator_U.In2[i] = 0.0;
    }

    for (i = 0; i < 20; i++) {
        for_loop_iterator_U.In3[i] = 0.0;
    }
}

```

The generated code declares the iteration variable, `i`, once.

## More efficient code for Boolean expressions

In R2016b, for a model containing a Logic block with the **Operator** parameter set to NXOR, the code generator removes an equality operator. Removing this operator makes the generated code less complex and more efficient.

For example, the model `nxor_example` contains two Inport blocks that connect to a Logic block. In the Inport block parameters dialog box, on the **Signal Attributes** tab, the **Data type** parameter is set to **Boolean**.

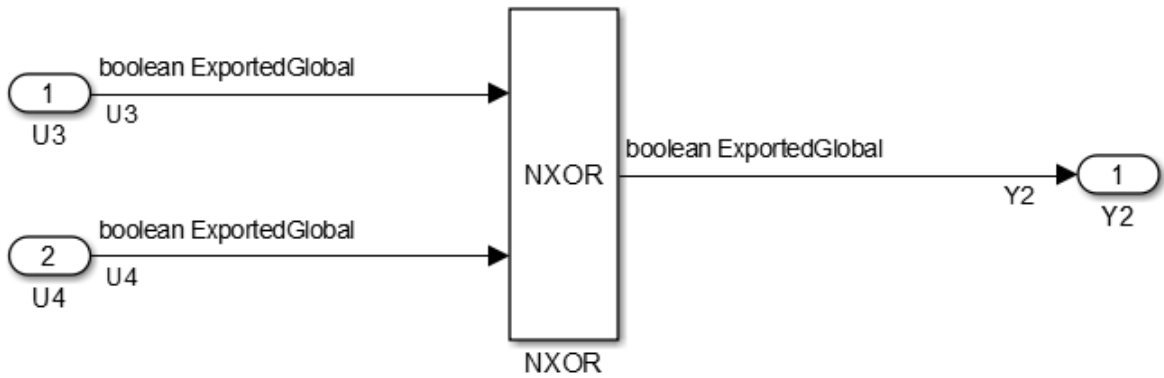

In R2016a, in the `nxor_example_step` function, the code generator produced this code:

```
void nxor_example_step(void)
{
    Y2 = !(U3 != U4);
}
```

The generated code contained two equality operators.

In R2016b, the code generator produces this code:

```
void nxor_example_step(void)
{
    Y2 = (U3 == U4);
}
```

The generated code contains one equality operator.



## Verification

### Verification of `size_t` and `ptrdiff_t` hardware settings

In R2016b, the **Configuration Parameters > Hardware Implementation** pane provides settings for the ANSI C data types `size_t` and `ptrdiff_t`. At the start of a processor-in-the-loop (PIL) simulation, the software verifies the settings with reference to the target hardware.

### Verification of PIL target connectivity configuration

Through the `piltest` function, you can use a test suite to verify your custom processor-in-the-loop (PIL) target connectivity configuration. Verify the target connectivity configuration early and independently of your model development and code generation.

For more information, see [Create PIL Target Connectivity Configuration](#).

### Signal range checking in SIL and PIL simulations

Top-model and Model block software-in-the-loop (SIL) and processor-in-the-loop (PIL) simulations support the **Configuration Parameters > Diagnostics > Data Validity > Simulation range checking** (`SignalRangeChecking`) diagnostic. With this diagnostic, you can detect mismatches between model and generated code simulations that arise when you specify the code optimization configuration parameter, `UseSpecifiedMinMax`. The range checking applies to only root-level I/O signals of the SIL or PIL component.

### SIL and PIL block support for Simulink Function and Function Caller blocks

You can run simulations with SIL and PIL blocks that you create from subsystems containing Simulink Function or Function Caller blocks. Function calls across the SIL or PIL block boundary are not supported.

## Check bug reports for issues and fixes

Software is inherently complex and is not free of errors. The output of a code generator might contain bugs, some of which are not detected by a compiler. MathWorks reports critical known bugs brought to its attention on its Bug Report system at [www.mathworks.com/support/bugreports/](http://www.mathworks.com/support/bugreports/). Use the Saved Searches and Watched Bugs tool with the search phrase "Incorrect Code Generation" to obtain a report of known bugs that produce code that might compile and execute, but still produce wrong answers.

The bug reports are an integral part of the documentation for each release. Examine periodically all bug reports for a release, as such reports may identify inconsistencies between the actual behavior of a release you are using and the behavior described in this documentation.

In addition to reviewing bug reports, you should implement a verification and validation strategy to identify potential bugs in your design, code, and tools.

# R2016a

**Version: 6.10**

**New Features**

**Bug Fixes**

**Compatibility Considerations**

## Code Generation from MATLAB Code

### Export data by using ExportedDefine storage class

In R2016a, when you generate C/C++ code from MATLAB code, you can use an `ExportedDefine` storage class to declare global variables with `#define` directives. The code generator emits these directives to the `entryfcn.h` header file. `entryfcn.h` is the name of the first entry-point function.

To assign the `ExportedDefine` storage class to a global variable, in your MATLAB code, use the `coder.storageClass` function. Only when you use an Embedded Coder project or configuration object for generation of C/C++ libraries or executables does the code generation software recognize `coder.storageClass` calls.

The syntax for `coder.storageClass` is:

```
coder.storageClass(var_name, storage_class)
```

`var_name` is the name of a global variable. Specify `var_name` as a constant string. Specify `storage_class` as `'ExportedDefine'`. For example, `coder.StorageClass('g', 'ExportedDefine')` assigns the `ExportedDefine` storage class to the global variable `g`. To assign the `ExportedDefine` storage class to a global variable, the global variable must be only read and not written to in the code.

### SIL execution returns standard output and standard error streams

During a SIL execution, the SIL application redirects the `stdout` and `stderr` streams. When the application terminates, the MATLAB Command Window now displays the information from the redirected streams.

The SIL application also provides a basic signal handler, which captures the POSIX<sup>®</sup> signals `SIGFPE`, `SIGILL`, `SIGABRT`, and `SIGSEV`. The SIL application includes the file `signal.h` for the signal handler.

The information from the redirected streams can help you to debug SIL applications that fail before the execution is complete. For example, you can view:

- Output from `printf` statements in your code.
- If you enable run-time error detection, messages sent to `stderr`.

- Some low-level system messages.

For more information, see [Debug SIL Execution](#).

## Model Architecture and Design

### Compile-Time Dimensions: Generate compiler directives (#define) for implementing signal dimensions

Previously, Simulink treated signal and parameter dimension specifications as numeric constants. In R2016a, you can use a `Simulink.Parameter` object as a symbol in a MATLAB expression to represent a dimension value. During simulation, Simulink propagates dimension symbols throughout the model and preserves these symbols in the propagated signal dimensions.

For example, in the model `sym_dim_ex`, the **Port Dimensions** parameter of `In1` is the `Simulink.Parameter D`.



The `sym_dim_ex.c` file contains the following code:

```
for (i = 0; i < D; i++) {
    sym_dim_ex_Y.Out1[i] = 2.0 * sym_dim_ex_U.In1[i];
}
```

In a header file, a macro defines the symbol `D`:

```
#define D 100
```

For the same model, if you change the value of `D`, the generated code remains the same except for the definition of `D`:

```
#define D 200
```

When you use symbols instead of numeric constants for dimension specifications, you can compile the same generated code into multiple applications of different sizes. When you simulate the model, you validate the behavior of the generated code for a set of symbolic dimension values. Change the values of the `Simulink.Parameter` objects that define the dimension symbols and simulate the model with the new values to check that the new values are valid.

For more information on how to specify dimensions with `Simulink.Parameters`, see [Implement Dimension Variants for Array Sizes in Generated Code](#)

The dimension variants feature is on by default. You can turn off this feature by clearing the Allow symbolic dimension specification parameter on the **All Parameters** tab of the Configuration Parameters dialog box.

## **Compile-Time Variants: Generate compiler directives (#if) for variant choices specified with Variant Source and Variant Sink blocks**

Previously, you used model variants and variant subsystems to make parts of a model conditional. Preprocessor conditionals controlled which child subsystem of the variant subsystem or which child model of the model variant was active in the generated code.

In R2016a, you can make parts of a model conditional without placing blocks inside variant subsystems or model variants. A Variant Source block enables variant choices at the source of a signal. For the Variant Source block, you can specify one or no active input port. A Variant Sink block enables variant choices at the destination of a signal. For the Variant Sink block, you can specify one or no active output port. During simulation, Simulink ignores blocks that connect to inactive ports.

When you generate code, you can generate code for only the active variant choice or generate preprocessor conditionals that defer the choice of active variant until compilation time. You can generate preprocessor conditionals that allow for no active variant choice. For more information, see [Represent Variant Source and Sink Blocks in Generated Code](#)

## **C++ Code Generation: Use referenced models with multitasking, export-functions, and virtual buses**

Previously, code generation for the C++ model class interface was limited to single tasking mode for model reference targets and non-virtual buses for crossing model boundaries. Also, the Export Function feature could not generate code for the C++ model class interface.

The C++ model class interface support in this release provides multitasking mode for model reference target, provides virtual bus for crossing model boundaries, and supports export function-call subsystems. For more information about using exported functions

with a C++ model class interface, see Export Function-Call Subsystems. For more information about multitasking and virtual buses with C++ code generation, see “Default style C++ interface replaces the void-void style C++ interface” on page 3-17.

## MISRA C:2012 Compliance: Check block names and Assignment blocks by using the Model Advisor

To improve MISRA C:2012 compliance, in the Model Advisor **By Task > Modeling Guidelines for MISRA C:2012** folder, you can run the following new checks.

Check	Description	Addresses MISRA C:2012 Rule
Check for unsupported block names	Identifies block names that contain a / character.	3.1
Check usage of Assignment blocks	Identifies Assignment blocks with incomplete array initialization that do not have block parameter <b>Action if any output element is not assigned</b> set to Error or Warning.	9.1

For information about MISRA C<sup>®</sup> versions and updates, see MISRA C Guidelines

## AUTOSAR Round Trip: Automate model additions for update and merge of ARXML files

Simulink provides the ability to merge AUTOSAR authoring tool changes into a model as part of round-trip iterations. R2016a adds more automation and better reporting to the merge process. The software:

- Automates Simulink block additions. In the updated model, green highlighting identifies the added blocks.
- Lists required Simulink block deletions. In the updated model, red highlighting identifies the blocks to delete.

For more information, see Import AUTOSAR Software Component Updates.



---

**Note:** This capability is available to R2015b Embedded Coder customers by installing the R2015b Embedded Coder Support Package for AUTOSAR Standard, Version 15.2.2 or later.

---

R2016a provides many other enhancements to Simulink modeling of AUTOSAR elements and AUTOSAR code generation. For more information, see:

- Under Model Architecture and Design:
  - “Variants in AUTOSAR component modeling” on page 3-7
  - “AUTOSAR DataReceivedEvents for receiver ports in ImplicitReceive data access mode” on page 3-9
  - “AUTOSAR LiteralPrefix for enumerations in IncludedDataTypeSets” on page 3-10
  - “Programmatic validation and synchronization of AUTOSAR model configurations” on page 3-10
- Under Code Generation:
  - “AUTOSAR arxml round trip” on page 3-18
  - “Improved AUTOSAR library support for Mfx functions” on page 3-20
  - “AUTOSAR target no longer supports building wrapper subsystem as AUTOSAR SW-Component” on page 3-21

## Comment change in generated code

In R2016a, for models containing hierarchical model elements such as a conditionally executed subsystem and either a reusable subsystem, a Stateflow Chart, or a model reference, there is a comment change in the generated code.

In R2015b, for the code that sets the initial conditions of block states inside these hierarchical model elements, the comment states `Initial Conditions` or `InitializeConditions`.

In R2016a, the comment states `System initialize` or `SystemInitialize`.

## Variants in AUTOSAR component modeling

R2016a enhances AUTOSAR component modeling with modeling support for:

- AUTOSAR variants in ports and runnables
- AUTOSAR variants in array sizes

### **AUTOSAR variants in ports and runnables**

AUTOSAR software components can use variants to enable or disable AUTOSAR elements, such as ports and runnables, based on defined conditions. Embedded Coder now supports modeling AUTOSAR variants in ports and runnables.

In Simulink, you can:

- Import AUTOSAR ports and runnables with variation points.

The `arxml` importer creates the required model elements, including workspace variables for modeling with variants, Variant Sink blocks, and Variant Source blocks to propagate variant conditions.

- Model AUTOSAR ports and runnables with variation points.
  - To define variant condition logic, use `Simulink.Variant` data objects.
  - To represent AUTOSAR system constants, use `AUTOSAR.Parameter` data objects with storage class `SystemConstant`.
  - To propagate variant conditions for the AUTOSAR elements, use Variant Sink and Variant Source blocks.
- Run validation on the AUTOSAR configuration. The validation software checks that variant conditions on Simulink blocks match the designed behavior from the imported `arxml` code.
- Export previously imported AUTOSAR ports and runnables with variation points.

For more information, see [Model AUTOSAR Variants and Configure AUTOSAR Variants in Ports and Runnables](#).

### **AUTOSAR variants in array sizes**

AUTOSAR software components can flexibly specify the dimensions of an AUTOSAR element, such as a port, by using a symbolic reference to a system constant. The system constant defines the array size of the port data type.

Embedded Coder now supports modeling AUTOSAR variants in array sizes.

In Simulink, you can:

- Import AUTOSAR elements with variant array sizes.
  - The `arxml` importer creates the required model elements, including `AUTOSAR.Parameter` data objects with storage class `SystemConstant`, to represent the array size values.
  - Each block created by the importer to represent an AUTOSAR element with variant array sizes references `AUTOSAR.Parameter` data objects to define its dimensions.
- Model AUTOSAR elements with variant array sizes.
  - Create blocks that represent AUTOSAR elements.
  - To represent array size values, add `AUTOSAR.Parameter` data objects with storage class `SystemConstant`.
  - To specify array size for an AUTOSAR element, reference an `AUTOSAR.Parameter` data object.
- Modify array size values in system constants and simulate the model, without regenerating code for simulation.
- Generate C and `arxml` code with symbols corresponding to variant array sizes.

For more information, see [Variants in Array Sizes and Configure AUTOSAR Variants in Array Sizes](#).

## **AUTOSAR `DataReceivedEvents` for receiver ports in `ImplicitReceive` data access mode**

R2016a enhances AUTOSAR sender-receiver modeling with support for `DataReceivedEvents` for receiver ports in `ImplicitReceive` data access mode. Previously, the software supported `DataReceivedEvents` for receiver ports only in `ExplicitReceive`, `QueuedExplicitReceive`, and `EndToEndRead` data access modes.

---

**Note:** This capability is available to R2015b Embedded Coder customers by installing the R2015b Embedded Coder Support Package for AUTOSAR Standard, Version 15.2.0 or later.

---

## AUTOSAR LiteralPrefix for enumerations in IncludedDataTypeSets

The arxml importer can now import AUTOSAR LiteralPrefixes defined in IncludedDataTypeSets. The software adds LiteralPrefixes to Simulink enumerated data types generated by the importer.

---

**Note:** This capability is available to R2015b Embedded Coder customers by installing the R2015b Embedded Coder Support Package for AUTOSAR Standard, Version 15.2.2 or later.

---

## Programmatic validation and synchronization of AUTOSAR model configurations

R2016a adds MATLAB functions for validating and synchronizing AUTOSAR model configurations:

- `autosar.api.validateModel` — Validate AUTOSAR properties and Simulink to AUTOSAR mapping of specified model.
- `autosar.api.syncModel` — Synchronize Simulink to AUTOSAR mapping of specified model with Simulink block modifications.

The functions are equivalent to using the **Validate**  and **Synchronize**  icons in the graphical views of an AUTOSAR configuration.

---

**Note:** This capability is available to R2015b Embedded Coder customers by installing the R2015b Embedded Coder Support Package for AUTOSAR Standard, Version 15.2.1 or later.

---

## Data, Function, and File Definition

### In/Out Arguments: Specify same variable name for in/out arguments of MATLAB Function and Model blocks

#### Buffer reuse across Model blocks

Previously, the code generator tried to reuse buffers for a pair of model step function input and output ports that were assigned the same argument name using function prototype control. This optimization decreases RAM/ROM consumption because there are less data copies and global variables in the generated code.

In R2016a, the code generator tries to reuse the input and output buffers of Model blocks.

For example, the model `parent_model` contains three copies of the model `child_model`.

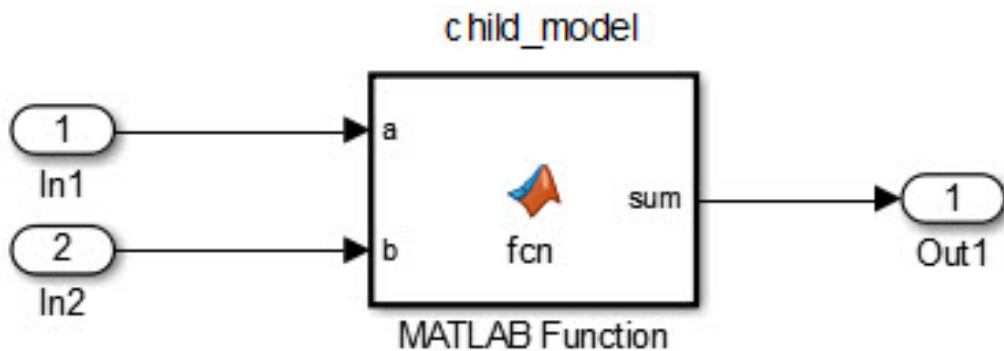
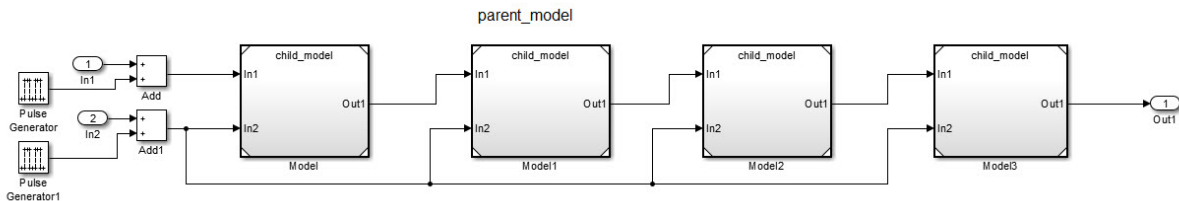

In R2015b and R2016a, the code generator produces the following code in `child_model.cpp`:

```
void bottommodel::step(real_T arg_Inout1[9], const real_T arg_In2[9])
{
    int32_T i;
    for (i = 0; i < 9; i++) {
        arg_Inout1[i] += arg_In2[i];
    }
}
```

The generated code uses the same buffer `arg_Inout1` for the input `In1` and the output `Out1`.

In R2015b, the code generator produces this code in `parent_model.cpp`:

```
void topmodel::step()
{
    real_T rtb_Model[9];
    real_T rtb_Model1[9];
    real_T rtb_Model2[9];
    int32_T rtb_PulseGenerator1;
    real_T rtb_Add[9];
    real_T rtb_Add1[9];
    int32_T i;
    ...
    for (i = 0; i < 9; i++) {
        rtb_Add[i] = parent_model_U.In1[i] + (real_T)rtb_PulseGenerator1;
    }
    ...

    for (i = 0; i < 9; i++) {
        rtb_Add1[i] = parent_model_U.In2[i] + (real_T)rtb_PulseGenerator1;
    }

    (void) memcpy(&rtb_Model[0], &rtb_Add[0],
                 9*sizeof(real_T));
    ModelMDLOBJ1.step(&rtb_Model[0], &rtb_Add1[0]);
    (void) memcpy(&rtb_Model1[0], &rtb_Model[0],
                 9*sizeof(real_T));
    Model1MDLOBJ2.step(&rtb_Model1[0], &rtb_Add1[0]);
    (void) memcpy(&rtb_Model2[0], &rtb_Model1[0],
```

```

        9*sizeof(real_T));
Model2MDL OBJ3.step(&rtb_Model2[0], &rtb_Add1[0]);
(void) memcpy(&parent_model_Y.Out1[0], &rtb_Model2[0],
        9*sizeof(real_T));
Model3MDL OBJ4.step(&parent_model_Y.Out1[0], &rtb_Add1[0]);
}

```

The code generator does not reuse the output of one child model as the input to the next child model. Instead, there is a full array data copy prior to each call to the model step function.

In R2016a, the code generator produces the following code:

```

void topmodel::step()
{
    int32_T rtb_PulseGenerator1;
    real_T rtb_Model2[9];
    real_T rtb_Add1[9];
    int32_T i;

    for (i = 0; i < 9; i++) {
        rtb_Model2[i] = parent_model_U.In1[i] + (real_T)rtb_PulseGenerator1;
    }

    ...

    for (i = 0; i < 9; i++) {
        rtb_Add1[i] = parent_model_U.In2[i] + (real_T)rtb_PulseGenerator1;
    }

    ModelMDL OBJ1.step(&rtb_Model2[0], &rtb_Add1[0]);
    Model1MDL OBJ2.step(&rtb_Model2[0], &rtb_Add1[0]);
    Model2MDL OBJ3.step(&rtb_Model2[0], &rtb_Add1[0]);
    memcpy(&parent_model_Y.Out1[0], &rtb_Model2[0], (uint32_T)(9U * sizeof(real_T)));
    Model3MDL OBJ4.step(&parent_model_Y.Out1[0], &rtb_Add1[0]);
}

```

The code generator reuses the output of each child model as the input to the next child model. As a result, there are three less local arrays and four less full array data copies in the generated code.

To configure model step function I/O arguments to allow buffer reuse, use either C function prototype control or C++ class interface control. When generating C code, there can be only one instance of the same Model Reference block in the parent model. When

generating C++ code, the same Model Reference block can occur multiple times in the parent model. For more information, see [Combine I/O Arguments in Model Step Interface](#)

### Buffer reuse across MATLAB Function blocks

In R2016a, you can specify the same variable name for the input and output of a MATLAB Function block. If you connect multiple MATLAB Function blocks with the same variable name for the input and output arguments, the code generator tries to reuse the output of one MATLAB Function block as the input to the next MATLAB Function block. This optimization conserves RAM/ROM consumption by reducing the number of local variables and data copies in the generated code.

For example, the model named `mb_reuse` contains four MATLAB Function blocks.

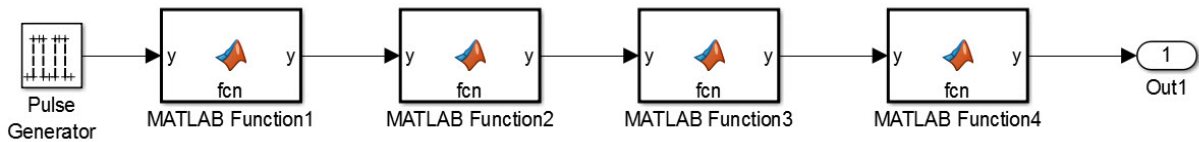

Each MATLAB Function block contains the following code:

```
function y = fcn(y)

y = y+4;
```

In R2016a, the code generator produces this code:

```
void mb_reuse_MATLABFunction1(real_T *rty_y)
{
    *rty_y += 4.0;
}
void mb_reuse_step(void)
{
    real_T rtb_y_p;
    rtb_y_p = (mb_reuse_DW.clockTickCounter < mb_reuse_P.PulseGenerator_Duty) &&
        (mb_reuse_DW.clockTickCounter >= 0) ? mb_reuse_P.PulseGenerator_Amp : 0.0;
    if (mb_reuse_DW.clockTickCounter >= mb_reuse_P.PulseGenerator_Period - 1.0) {
        mb_reuse_DW.clockTickCounter = 0;
    } else {
        mb_reuse_DW.clockTickCounter++;
    }

    mb_reuse_MATLABFunction1(&rtb_y_p);
}
```



```

    mb_reuse_MATLABFunction1(&rtb_y_p);
    mb_reuse_MATLABFunction1(&rtb_y_p);
    mb_reuse_Y.Out1 = rtb_y_p;
    mb_reuse_MATLABFunction1(&mb_reuse_Y.Out1);
}

```

The code generator reuses the variable `rtb_y_p` for the input and output arguments of each MATLAB Function block.

On the **Code Generation** tab in the subsystem Block Parameters dialog box, if **Function packaging** is set to `Nonreusable function` and **Function interface** is set to `Allows arguments`, the code generator cannot reuse the input and output buffers.

## Custom Storage Class Type AccessFunction

In R2016a, you can use the Custom Storage Class Designer to create custom storage classes of the new type `AccessFunction`. These custom storage classes access data in the generated code through functions whose custom definitions you provide. The built-in custom storage class `GetSet` from the package `Simulink` now uses this type.

You can configure these attributes as instance-specific or as common to all data items that use the custom storage class:

- For your `get` and `set` functions, a naming scheme that uses the name of each data item
- The name of the header file in which you provide the function prototypes

When you copy the `+SimulinkDemos` package to create your own data class package, you can modify the definition of the custom storage class `GetSet` by using the Custom Storage Class Designer.

For more information about the built-in custom storage class `GetSet`, see [Access Data Through Functions with Custom Storage Class GetSet](#). To create custom storage classes, see [Design Custom Storage Classes and Memory Sections](#).

## Creation of custom storage classes for macros defined by compiler options

Previously, the built-in custom storage class `CompilerFlag` used the type `Other`. In R2016a, `CompilerFlag` uses the type `Unstructured` and represents an imported macro that does not require a header file.

To import macros that you define by configuring compiler options, you can use `CompilerFlag` or create your own custom storage class. In the Custom Storage Class Designer:

- Set **Data initialization** to `Macro`.
- Set **Data scope** to `Imported`.
- Set **Header file** to `Specify`. Omit the header file name.

For more information, see [Design Custom Storage Classes and Memory Sections](#).

## Generation of ERT S-functions that represent variant controls as preprocessor conditionals

Previously, when you generated an ERT S-function from a subsystem, `Simulink.Parameter` objects that you selected as tunable appeared in the S-function code as tunable global variables. You could change the values of these parameters in the S-Function block dialog box during simulation.

In R2016a, if a `Simulink.Parameter` object uses a custom storage class that treats the parameter as a macro in the generated code, you cannot select the parameter as a tunable parameter for the generated S-function. Instead, the S-function code generator applies the custom storage class to the parameter object. This generation of macros in the S-function code allows you to generate S-functions from subsystems that contain variant elements, such as Variant Subsystem blocks, that you configure to produce preprocessor conditionals in the generated code. However, you cannot change the value of the parameter during simulation of the S-function.

For more information about generating S-functions from subsystems, see [Macro Parameters](#).

## Compatibility Considerations

If you apply macro custom storage classes to `Simulink.Parameter` objects, you can no longer select the parameter objects as tunable parameters when you generate an ERT S-function. To select these parameter objects as tunable parameters, apply a different storage class or custom storage class.

## Code Generation

### Default style C++ interface replaces the void-void style C++ interface

In C++ class interface support, the **Default step method** replaces the **Void-void step method**. The default style interface adds support for:

- Multitasking mode for model reference target
- Virtual bus for crossing model boundaries

When the **Code Generation** pane selection for **System target file** is `ert.tlc` (or is an ERT-derived target), the **Code Generation** pane selection for **Language** is C++, and the **Code Generation > Interface** pane selection for **Code interface packaging** is `C++ class`, you click the **Configure C++ Class Interface** button to configure the step method for your model.

For models configured to use the **Void-void step method**, the code generator treats this replaced configuration as the **Default step method**. No incompatibility occurs for the model configuration.

`RTW.ModelCPPDefaultClass` replaces `RTW.ModelCPPVoidClass`. Where code uses the replaced `RTW.ModelCPPVoidClass` class, update the code to use the `RTW.ModelCPPDefaultClass`, otherwise potential incompatibility can occur.

For information about the step methods, see *Control Generation of C++ Class Interfaces*. For information about using an ERT-derived target with C++ support, see *Support C++ Class Interface Control*.

### Compiler warning limitation removed for portable word sizes in SIL simulations

Prior to R2016a, compilation warnings occurred for code generated by using portable word sizes if all of the following conditions existed:

- The combination of word sizes for the host and target computers caused `rtwtypes.h` to redefine the word sizes by using preprocessor macros. For example, when the target computer had a 16-bit `int` data type and the host computer had a 16-bit `short` data type, `int16_T` was redefined to be `short` on the host computer and `int` on the target

computer. The data types were used for pointer arguments to function calls. The called functions resided on the host computer and were precompiled (not compiled using `rtwtypes.h`).

- The data types were used in pointer arguments to function calls.
- The called functions resided on the host computer and were precompiled (not compiled by using `rtwtypes.h`).

Under these conditions, the compiler typically issued a warning similar to the following warning:

```
warning: passing argument 2 of 'frexp' from incompatible pointer type
```

Executing the generated code on the host computer led to memory corruption. For example, the function `double frexp (double value, int *exp);` expected `int *` as the second argument. However, `int16_T *` is passed in the generated code. On the host computer, `int16_T` was redefined to `short`. During SIL simulation, `frexp` attempted to write four bytes to a 2-byte location.

The suggested workaround for this limitation was to develop a custom code replacement library for functions that wrote to address locations obtained through pointer arguments.

As of R2016a, this limitation does not apply. When you select portable word sizes, if possible, the code generator handles unsized arguments for standard library functions registered in libraries that MathWorks® provides. For unhandled cases, the code generator reports an error.

If user-defined code replacements use arguments of word sizes that map to settings of hardware implementation model configuration parameters, and you select portable word sizes, the code generator issues a warning.

If you use portable word sizes, when possible, define the size of arguments.

For more information, see [Configure Hardware Implementation Settings and Enable portable word sizes](#).

## **AUTOSAR arxml round trip**

R2016a enhances the AUTOSAR arxml round-trip workflow with support for:

- CompuMethods with LINEAR and TEXTTABLE COMPU-SCALEs

- `PredefinedVariants` import and export
- Enhanced control of AUTOSAR package path specification

### CompuMethods with LINEAR and TEXTTABLE COMPU-SCALEs

In R2016a, you can import and export a `CompuMethod` that uses `LINEAR` and `TEXTTABLE` scaling. Importing application data types that reference `CompuMethods` of category `SCALE_LINEAR_AND_TEXTTABLE` creates `Simulink.NumericType` or `Simulink.AliasType` data objects in the Simulink workspace. In Simulink, you can modify the `LINEAR` scaling for the `CompuMethods`. The `TEXTTABLE` scaling is read-only.

For more information, see `CompuMethod Categories for Data Types and Modify Linear Scaling for SCALE_LINEAR_AND_TEXTTABLE CompuMethod`.

---

**Note:** This capability is available to R2015b Embedded Coder customers by installing the R2015b Embedded Coder Support Package for AUTOSAR Standard, Version 15.2.1 or later.

---

### PredefinedVariants import and export

For an AUTOSAR software component that contains variation points, to define the values that control variation points, you can use the following AUTOSAR elements:

- `SwSystemconst` — Defines a system constant that serves as an input to control a variation point.
- `SwSystemconstantValueSet` — Specifies a set of system constant values.
- `PredefinedVariant` — Describes a combination of system constant values, among potentially multiple valid combinations, to apply to an AUTOSAR software component.

Previously, when creating a model from `arxml` code, the `arxml` importer did not provide a way to specify a `PredefinedVariant` or `SwSystemconstantValueSets` as a basis for resolving variation points in the model.

In R2016a, you can resolve variation points in an AUTOSAR software component at model creation time. Specify a `PredefinedVariant` or `SwSystemconstantValueSets` with which the importer can initialize `SwSystemconst` data.

After model creation, you can run simulations and generate code based on the combination of variation point input values that you specified.

For more information, see [Model AUTOSAR Variants and Control AUTOSAR Variants with Predefined Value Combinations](#).

### Enhanced control of AUTOSAR package path specification

In R2016a, if you modify an AUTOSAR package path, and if packageable elements of that category are affected, you can:

- Move the elements from the existing package to the new package.
- Set the new package path without moving the elements.

If you modify a package path in the Configure AUTOSAR Interface dialog box, and if packageable elements of that category are affected, a dialog box opens with control options. If you programmatically modify a package path, you can use the `MoveElements` property to specify handling of affected elements.

For more information, see [Control AUTOSAR Elements Affected by Package Path Modifications](#).

---

**Note:** This capability is available to R2015b Embedded Coder customers by installing the R2015b Embedded Coder Support Package for AUTOSAR Standard, Version 15.2.0 or later.

---

### Improved AUTOSAR library support for Mfx functions

As of R2016a, the AUTOSAR 4.0 code replacement library (CRL) replaces `abs`, `saturate`, `min`, and `max` function calls that involve operands with equal slope and bias with calls to corresponding Mfx functions.

Calls To	Replace
Mfx_Abs	<code>abs</code> with operands that have equal slope
Mfx_Limit	<code>saturate</code> with operands that have equal slope and bias
Mfx_Max	<code>max</code> with operands that have equal slope and bias
Mfx_Min	<code>min</code> with operands that have equal slope and bias

For more information about using the AUTOSAR 4.0 CRL, see Code Generation with AUTOSAR Library.

## **AUTOSAR target no longer supports building wrapper subsystem as AUTOSAR SW-Component**

In R2016a, the AUTOSAR target removes support for using right-click builds to build a wrapper subsystem that models an AUTOSAR SW-Component. In R2013b, a top model approach to modeling multirunnable AUTOSAR SW-Components replaced the wrapper subsystem approach. For more information, see Multi-Runnable Software Components and Configure AUTOSAR Multiple Runnables.

## **Compatibility Considerations**

In R2016a, if you try to configure and build an AUTOSAR SW-Component by using a wrapper subsystem, the software issues an error message. The message states that configuring a subsystem as an AUTOSAR SW-Component is not supported.

To convert subsystem multirunnables to top model multirunnables, use the subsystem-to-model conversion techniques described in Convert a Subsystem to a Referenced Model. After the basic conversion, you must manually reestablish some AUTOSAR configuration information from the subsystem configuration in the new configuration.

## **Root model name in generated identifier for shared utility files**

In R2016a, you can add the root model name to the generated identifier for shared utility files. When you merge code for multiple models, including the root model name in the generated identifier avoids name clashes. Name clashes arise due to identical shared utility file names.

To specify that the code generator add the root model name, in the Configuration Parameters dialog box, on the **Code Generation > Symbols** pane, add the \$R token to the **Shared Utilities** field.

## **Improved configuration parameter defaults for Embedded Coder targets**

Improved configuration parameter defaults for Embedded Coder targets enable more optimizations and traceability options. These parameter defaults make it easier to develop your model for production code generation. In R2016a, when you switch your

system target file to `ert.tlc`, the following configuration parameters are enabled by default:

- **Convert if-elseif-else patterns to switch-case statements** (ConvertIfToSwitch)
- **Suppress generation of default cases for Stateflow switch statements if unreachable** (SuppressUnreachableDefaultCases)
- **Simulink data object descriptions** (SimulinkDataObjDesc)
- **Simulink block descriptions** (InsertBlockDesc)
- **Verbose comments for SimulinkGlobal storage class** (ForceParamTrailComments)
- **Open report automatically** (LaunchReport)
- **Create code generation report** (GenerateReport)
- **Stateflow object descriptions** (SFDataObjDesc)
- **Show eliminated blocks** (ShowEliminatedStatement)
- **Operator annotations** (OperatorAnnotations)
- **MATLAB function help text** (MATLABFcnDesc)
- **MATLAB source code as comments** (MATLABSourceComments)
- **Traceable Simulink blocks** (GenerateTraceReportS1)
- **Traceable Stateflow objects** (GenerateTraceReportSf)
- **Traceable MATLAB functions** (GenerateTraceReportEm1)
- **Model-to-code** (GenerateTraceInfo)
- **Code-to-model** (IncludeHyperlinkInReport)
- **Eliminated / virtual blocks** (GenerateTraceReport)

## Streamlined code generation panes for easier model configuration

In the Configuration Parameters dialog box, streamlined category panes display only configuration parameters that you are most likely to use when configuring your model for code generation.

The category panes, previously referred to as the Category view, are now available on the **Commonly Used Parameters** tab. The **All Parameters** tab, previously referred to as the List view, provides the complete list of parameters in the model configuration set.



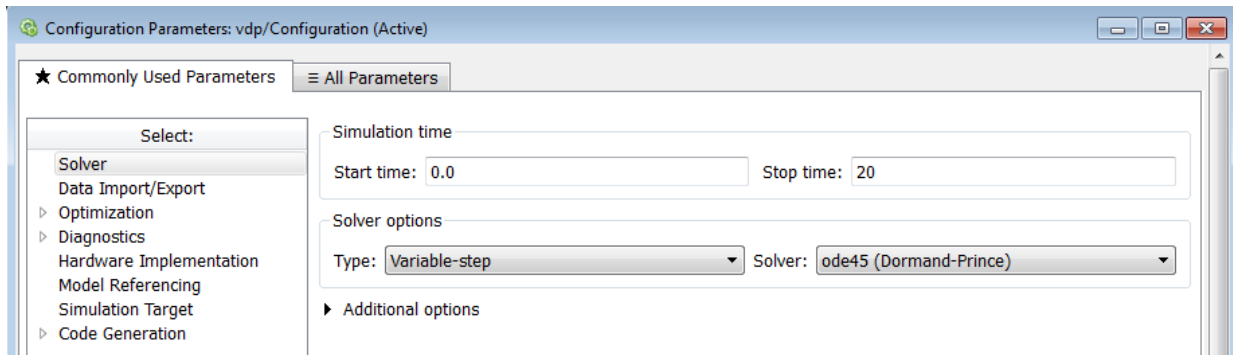

## Compatibility Considerations

Following are the configuration parameters that have moved to the **All Parameters** tab or moved to a different pane.

---

**Note:** Parameters that are removed from a pane are still available for configuration on the **All Parameters** tab. To locate a parameter on this tab, use either the search box or the **Category** filter.

---

### Code Generation Pane

The following are moved to the **All Parameters** tab:

- **Ignore custom storage classes** parameter
- **Ignore test point signals** parameter
- **Validate** button for **Toolchain** parameter

### Code Generation > Interface Pane

The following parameters are moved to the **All Parameters** tab:

- **Standard math library**
- **Support: non-inlined S-functions**
- **Multiword type definitions**
- **Maximum word length**

- **Use dynamic memory allocation for model initialization**
- **Classic call interface**
- **Single output/update function**
- **Terminate function required**
- **Combine signal/state structures**
- **Internal data visibility**
- **Internal data access**
- **Generate destructor**
- **Use dynamic memory allocation for model block instantiation**
- **MAT-file logging**
- **MAT-file variable name modifier**

#### **Code Generation > Debug Pane**

The pane is removed and its parameters are moved to the **All Parameters** tab:

- **Profile TLC**
- **Verbose build**
- **Retain .rtw file**
- **Enable TLC assertion**
- **Start TLC coverage when generating code**
- **Start TLC debugger when generating code**

#### **Code Generation > Verification Pane**

The following parameter is moved to the **All Parameters** tab:

- **Create block**

#### **Data Import/Export Pane**

The **Enable live streaming of selected signal to Simulation Data Inspector** parameter is moved to the **All Parameters** tab.

The following parameters are available by clicking **Additional Parameters** at the bottom of the pane:

- **Limit data points to last**

- **Decimation**
- **Output options**
- **Refine factor**

### **Diagnostics Pane**

The following parameter is moved to the **All Parameters** tab:

- **Solver data inconsistency**

### **Diagnostics > Data Validity Pane**

The following parameters are moved to the **All Parameters** tab:

- **Array bounds exceeded**
- **Model verification block enabling**
- **Check preactivation output of execution context**
- **Check runtime output of execution context**
- **Check undefined subsystem initial output**
- **Detect multiple driving blocks executing at the same time step**
- **Underspecified initialization detection**

### **Diagnostics > Saving Pane**

The pane is removed and its parameters are moved to the **All Parameters** tab:

- **Block diagram contains disabled library links**
- **Block diagram contains parameterized library links**

### **Diagnostics > Solver Pane**

The following parameters are moved to the **Diagnostics > Sample Time** pane:

- **Sample hit time adjusting**
- **Unspecified inheritability of sample time**

The following parameter is moved to the **Diagnostics > Compatibility** pane:

- **SimState object from earlier release**

### **Optimization Pane**

The following parameters are moved to the **All Parameters** tab:

- **Remove code from floating-point to integer conversions with saturation that maps NaN to zero**
- **Compiler optimization level**
- **Verbose accelerator builds**
- **Implement logic signals as Boolean data (vs. double)**
- **Block reduction**
- **Conditional input branch execution**
- **Use memset to initialize floats and doubles to 0.0**

### **Optimization > Signals and Parameters Pane**

The following parameters are moved to the **All Parameters** tab:

- **Signal storage reuse**
- **Enable local block outputs**
- **Reuse local block outputs**
- **Optimize global data access**
- **Reuse global block outputs**
- **Eliminate superfluous local variables (Expression folding)**
- **Simplify array indexing**

### **Simulation Target Pane**

The following parameters are moved to the **All Parameters** tab:

- **Echo expressions without semicolons**
- **Simulation target build mode**
- **Ensure responsiveness**
- **Generate typedefs for imported bus and enumeration types**
- **Ensure memory integrity**

### **Simulation Target > Custom Code Pane**

The pane is removed and its parameters are moved to the **Simulation Target** pane:

- **Header file**
- **Initialize function**
- **Source file**
- **Terminate function**
- **Parse custom code symbols**
- **Include directories**
- **Libraries**
- **Source files**
- **Defines**

### **Simulation Target > Symbols Pane**

The pane is removed and its parameter is moved to the **Simulation Target** pane:

- **Reserved names**

### **Build button removed from Configuration Parameters dialog box**

The **Build / Generate Code** button is no longer available on the **Code Generation** pane in the Configuration Parameters dialog box.

### **Compatibility Considerations**

To initiate code generation and the build process, press **Ctrl-B** or, on the Simulink Editor toolbar, click the **Build Model** icon.

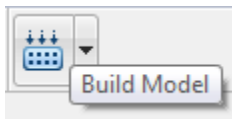

### **Improved web view for code generation report**

In R2016a, significant updates improve the model Web view in the code generation report. Updates include:

- Graphics and navigation similar to the Simulink Editor.

- Block parameter and signal property value inspection using the **Object Inspector** pane.
- Model search for locating Simulink blocks and Stateflow objects.
- Tab support for displaying individual block diagrams.

For more information, see the Simulink Report Generator™ documentation.

## Dependent parameters not added to custom code generation objective

Previously, when you added a parameter to a custom code generation objective using the `addParam` function, the software included the parameter dependencies in the list of parameter values that the Code Generation Advisor reviews. In R2016a, these dependent parameters are not added.

## Removal of leading underscore character in macro type definitions

In R2015b, generated type definition macros began with an underscore character (`_`). In R2016a, the code generator does not include the underscore character at the beginning of these macros. This change in the generated code addresses MISRA C:2012 Rule 21.1.

For example, in R2015b, the code generator produced this code for an enumeration type definition:

```
#ifndef _DEFINED_TYPEDEF_FOR_EnumErrorType_
#define _DEFINED_TYPEDEF_FOR_EnumErrorType_

typedef enum {
    NoError = 0,                /* Default value */
    MeasuredVelocityError
} EnumErrorType;

#endif
```

The code contained an underscore character at the beginning of the name `_DEFINED_TYPEDEF_FOR_EnumErrorType_`.

In R2016a, the code generator produces this code for the same type definition:

```
#ifndef DEFINED_TYPEDEF_FOR_EnumErrorType_
#define DEFINED_TYPEDEF_FOR_EnumErrorType_
```

```
typedef enum {  
    NoError = 0,                /* Default value */  
    MeasuredVelocityError  
} EnumErrorType;  
  
#endif
```

The code does not contain an underscore character at the beginning of the name `DEFINED_TYPEDEF_FOR_EnumErrorType_`.

## Deployment

### Hardware implementation parameters enabled by default

In R2016a, the **Enable hardware specification** button is removed from the **Configuration Parameters > Hardware Implementation** pane. By default, the parameters on the pane are enabled.

### MATLAB Coder PIL With ARM Cortex-A: Verify and profile ARM optimized code with Altera SoC and Xilinx Zynq hardware

In R2016a, you can use processor-in-the-loop (PIL) executions to verify generated code that you deploy to target hardware using a MATLAB Coder workflow with an Embedded Coder license. By using PIL with hardware, you can more effectively generate customized code for your hardware by profiling speed and algorithm performance. You have the option of using the command-line workflow or the MATLAB Coder app to configure your target hardware for PIL executions.

This PIL execution is available with the following hardware support packages:

- Embedded Coder Support Package for Altera SoC Platform
- Embedded Coder Support Package for Xilinx Zynq-7000 Platform

To use this PIL execution, you must install one of these support packages. For more information, see:

- PIL Execution with ARM Cortex-A at the Command Line
- PIL Execution with ARM Cortex-A by Using the MATLAB Coder App

### Updates to support package for Texas Instruments C2000 processors

The updated Embedded Coder Support Package for Texas Instruments C2000™ Processors, adds the code generation support for Texas Instruments Delfino F2837xD, F2837xS and Texas Instruments Piccolo F2807x processors. You must install the Embedded Coder Support Package for Texas Instruments C2000 Processors to use this support.

To install or update this support package, perform the steps described in Install Support for TI's C2000 Processors.



---

For more information, see Texas Instruments C2000 Processors.

## **Support package for Freescale FRDM-K64F board**

You can use the Embedded Coder Support Package for Freescale™ FRDM-K64F Board to generate, build, and deploy code to the Freescale FRDM-K64F board. See Install Support for Freescale FRDM-K64F Board. For more information, see Embedded Coder Support Package for Freescale FRDMK64F Board.

## **Support for TI's C5000 DSPs will be removed**

Support for TI's C5000™ DSPs will be removed. You can still use Embedded Coder for TI's C5000 processors, but need to manually integrate the generated code with hand written schedulers and drivers.

## **Support for TI's C6000 DSPs will be removed**

Support for TI's C6000 DSPs will be removed in a future release. You will still be able to use Embedded Coder for TI's C6000 processors, but will need to manually integrate the generated code with hand written schedulers and drivers.

## **Change in base product for ARM Cortex-Based VEX Microcontroller support package**

The base product for ARM Cortex-Based VEX Microcontroller support package is changed from Embedded Coder to Simulink Coder. However, you can use this support package with Embedded Coder to use some of the Embedded Coder features. For more information on Simulink Coder Support Package for ARM Cortex-based VEX® Microcontroller, see Simulink Coder Support Package for ARM Cortex-Based VEX Microcontroller.

## Performance

### Data Buffer Reuse: Use same variable for multiple signals in a path by using the same Reusable storage class specification

Previously, if the input and output signals at a block or subsystem boundary shared the same `Reusable` storage class specification, the code generator tried to reuse the signals in the generated code.

In R2016a, this optimization extends to blocks or subsystems that are in a path. The optimization decreases RAM/ROM consumption by reducing the number of global variables and data copies in the generated code.

For more information, see [Buffer Reuse Around a Block or Subsystem Boundary](#).

### Reuse input, output, and state of Delay block

Previously, the code generator reused the input, output, and state of a Unit Delay block. In R2016a, the code generator tries to reuse the input, output, and state of a Delay block if in the Delay block parameters dialog box, the following conditions exist:

- The **Delay length** parameter has a value of 1.
- The **Initial condition > Source parameter** is set to Dialog.

For more information, see [Buffer Reuse for Model Block Boundary and Unit Delay](#).

### Initialization code occurs once after start code in `model_initialize` function

In R2016a, for conditionally executed subsystems, there are the following changes in the generated code for the `model_initialize` function:

- In R2015b, the code generator called the `model_Subsystem_Init` function possibly before and after the `model_Subsystem_Start` function. In R2016a, the generated code contains one call to the `model_Subsystem_Init` function. This call occurs after the `model_Subsystem_Start` function. One call reduces code size and improves ROM consumption.

- In R2015b, the *model\_Subsystem\_Start* function and the *model\_Subsystem\_Init* function initialized the states of blocks. In R2016a, the *model\_Subsystem\_Init* function initializes the states of blocks. The *model\_Subsystem\_Start* function still performs other tasks involving a small selection of blocks.

For example, in the model `cond_sub`, a Mux block combines the signals from two enabled subsystems into one signal. This signal feeds into a function-call subsystem. One of the outputs from the function-call subsystem is the combination of signals from two subsystems. The other output is the signal from the Unit Delay block.

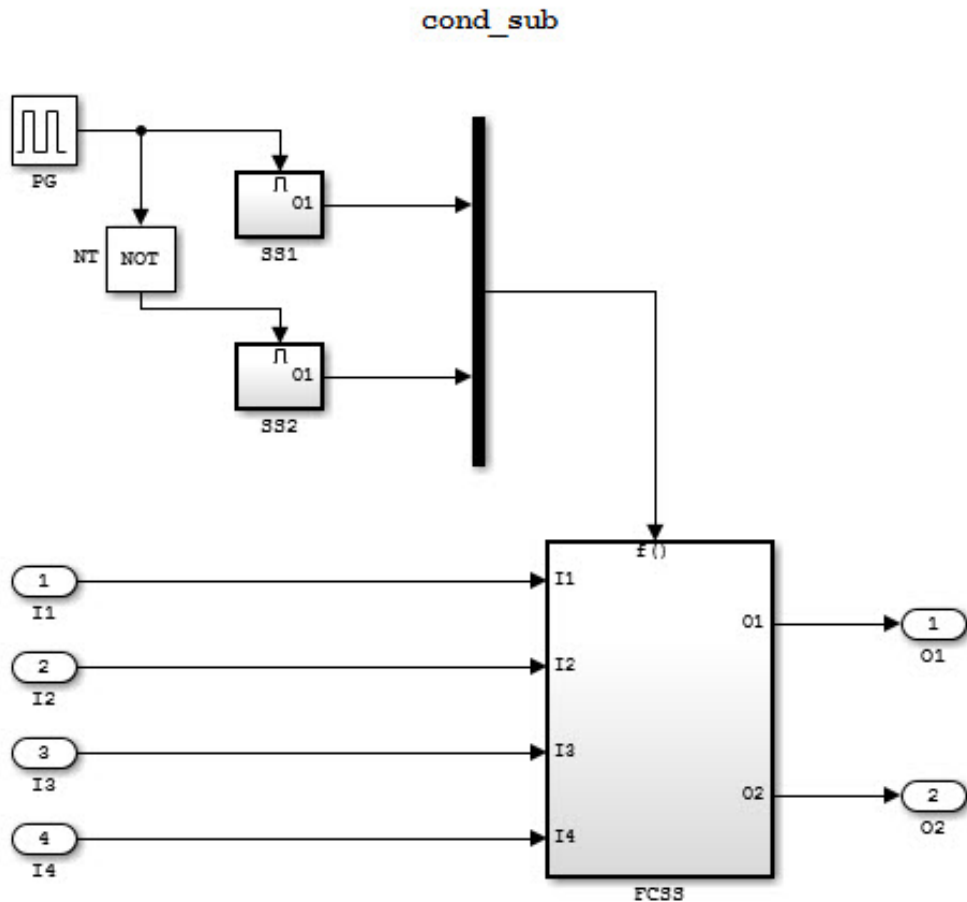

## Contents of FcnCall SS

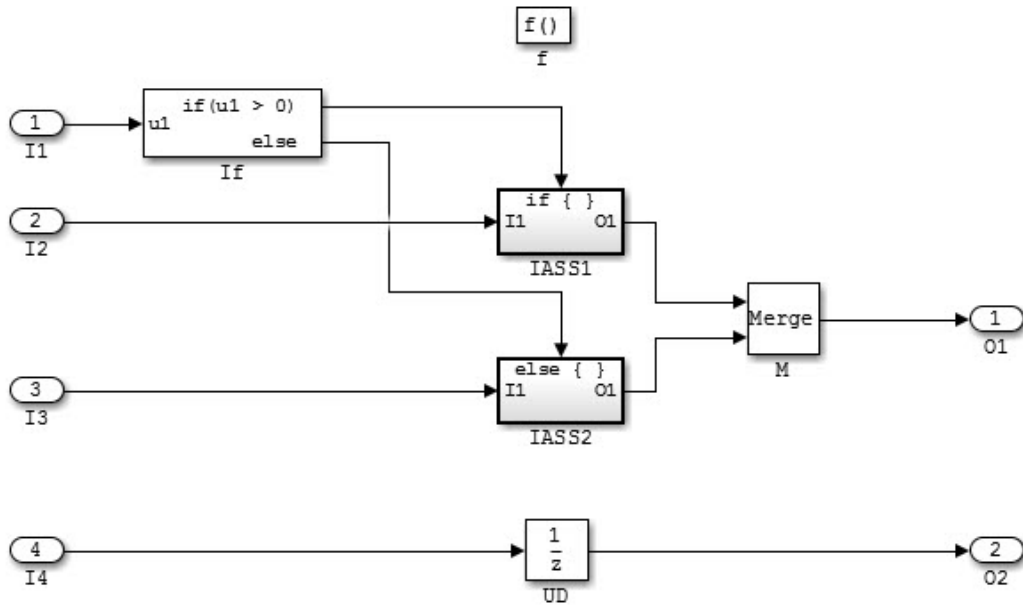

In R2015b, the code generator produced this code in the `cond_sub.c` file:

```

void cond_sub_IASS1_Init(void)
{
    cond_sub_DW.UD_DSTATE_c = 0.0;
}
void cond_sub_IASS1_Start(void)
{
    cond_sub_IASS1_Init();
}
...

void cond_sub_FCSS_Init(void)
{
    cond_sub_DW.UD_DSTATE = 2.0;
}
...

```

```

void cond_sub_FCSS_Start(void)
{
    cond_sub_DW.If_ActiveSubsystem = -1;
    cond_sub_IASS1_Start();
    cond_sub_B.M = 3.0;
    cond_sub_Y.01 = 4.0;
}

void cond_sub_initialize(void)
{
    (void) memset((void *)&cond_sub_U, 0,
                 sizeof(ExtU_cond_sub_T));
    (void) memset((void *)&cond_sub_Y, 0,
                 sizeof(ExtY_cond_sub_T));
    cond_sub_FCSS_Init();
    cond_sub_FCSS_Start();
    cond_sub_FCSS_Init();
}

```

The `cond_sub_initialize` function calls the `cond_sub_FCSS_Init` function before and after the `cond_sub_FCSS_Start` function. The `cond_sub_FCSS_Init` function sets the initial condition of the Unit Delay block. The `cond_sub_FCSS_Start` function sets the initial conditions of the Merge block and the Output block, 01.

In R2016a, the code generator produces this code in the `cond_sub.c` file:

```

void cond_sub_FCSS_Init(void)
{
    cond_sub_DW.UD_DSTATE = 2.0;
    cond_sub_B.M = 3.0;
    cond_sub_Y.01 = 4.0;
}
...
void cond_sub_FCSS_Start(void)
{
    cond_sub_DW.If_ActiveSubsystem = -1;
}
...
void cond_sub_initialize(void)
{
    (void) memset((void *)&cond_sub_U, 0,
                 sizeof(ExtU_cond_sub_T));
    (void) memset((void *)&cond_sub_Y, 0,
                 sizeof(ExtY_cond_sub_T));
}

```

```
    cond_sub_FCSS_Start();
    cond_sub_FCSS_Init();
}
```

In R2016a, the `cond_sub_FCSS_Start` function occurs once before the `cond_sub_FCSS_Init` function. The `cond_sub_FCSS_Init` function sets the initial condition of the Merge block, the Outport block, O1, and the Unit Delay block. The `cond_sub_FCSS_Start` function does not set the initial conditions of blocks.

## Reset function improves initialization code optimization

In R2016a, for models containing a conditionally executed subsystem and a reusable subsystem or model reference, the initialization code contains a new function called `model_Reset` or `subsystem_Reset`. The `model_Reset` or `subsystem_Reset` function sets the states of blocks inside a subsystem or model reference back to their initial conditions. The `subsystem_Init` function sets the states of blocks inside a model reference or subsystem to their initial conditions for the first time.

In the Configuration Parameters dialog box, when you select **Optimization > Remove internal data zero initialization**, the code generator does not generate code that initializes internal work structures to zero. This optimization reduces code size and increases execution speed.

For example, in the `cond_sub` model (shown in this release note: “Initialization code occurs once after start code in `model_initialize` function” on page 3-32), the function-call subsystem contains two Unit Delay blocks. One Unit Delay block connects to the output, O2 and has an initial condition of 2. The other Unit Delay block is inside the subsystem IASS1 and has an initial condition of 0.

In R2015b, the code generator produced the following code in the `cond_sub.c` file:

```
void cond_sub_IASS1_Init(void)
{
    /* InitializeConditions for UnitDelay: '<S4>/UD' */
    cond_sub_DW.UD_DSTATE_c = 0.0;
}
...
void cond_sub_FCSS_Init(void)
{
    /* InitializeConditions for UnitDelay: '<S1>/UD' */
    cond_sub_DW.UD_DSTATE = 2.0;
}
```

In R2015b, the code generator creates the `cond_sub_FCSS_Init` and the `cond_sub_IASS1_init` functions to initialize and reset the state of each Unit Delay block.

In R2016a, the code generator produces the following code inside of the `cond_sub.c` file:

```

/* System reset for action system: '<S1>/IASS1' */
void cond_sub_IASS1_Reset(void)
{
    /* InitializeConditions for UnitDelay: '<S4>/UD' */
    cond_sub_DW.UD_DSTATE_c = 0.0;
}
...
/* System initialize for function-call system: '<Root>/FCSS' */
void cond_sub_FCSS_Init(void)
{
    /* InitializeConditions for UnitDelay: '<S1>/UD' */
    cond_sub_DW.UD_DSTATE = 2.0;

    /* SystemInitialize for Merge: '<S1>/M' */
    cond_sub_B.M = 3.0;

    /* SystemInitialize for Outport: '<Root>/O1' incorporates:
     * SystemInitialize for Outport: '<S1>/O1'
     */
    cond_sub_Y.O1 = 4.0;
}

/* System reset for function-call system: '<Root>/FCSS' */
void cond_sub_FCSS_Reset(void)
{
    /* InitializeConditions for UnitDelay: '<S1>/UD' */
    cond_sub_DW.UD_DSTATE = 2.0;
}

```

In R2016a, the `cond_sub_FCSS_init` function initializes the state of one Unit Delay block. The code generator does not generate a `cond_sub_IASS1_Init` function to initialize the state of the other Unit Delay block to zero because the **Remove internal data zero initialization** parameter is selected.

The `void cond_sub_IASS1_Reset` and the `void cond_sub_FCSS_Reset` functions reset the states of the Unit Delay blocks.

If you know that a parent model does not have to reset the states of blocks inside a model reference, you can remove the `model_Reset` function from the generated code. In the Configuration Parameters dialog box, select **Optimization** > **Optimize initialization code for model reference** to remove the `model_Reset` function.

## Removal of unnecessary `rtmIsFirstInitCond` flag

In R2015b, for modeling patterns involving conditionally executed subsystems, the code generator created an `rtmIsFirstInitCond` flag in the `model_initialize` function and in the `model_step` function.

In R2016a, the code generator does not generate the `rtmIsFirstInitCond` flag, except for S-Function blocks. This enhancement reduces code size and ROM consumption and enables code reuse and a Simulink Code Inspector™ verification.

For example, the model `removeflag` contains a subsystem. This subsystem contains an enabled and triggered subsystem and a triggered subsystem that feed into a Merge block.

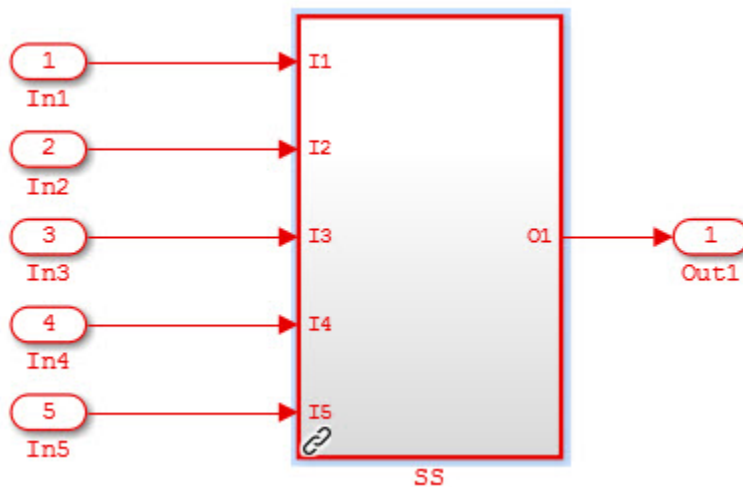



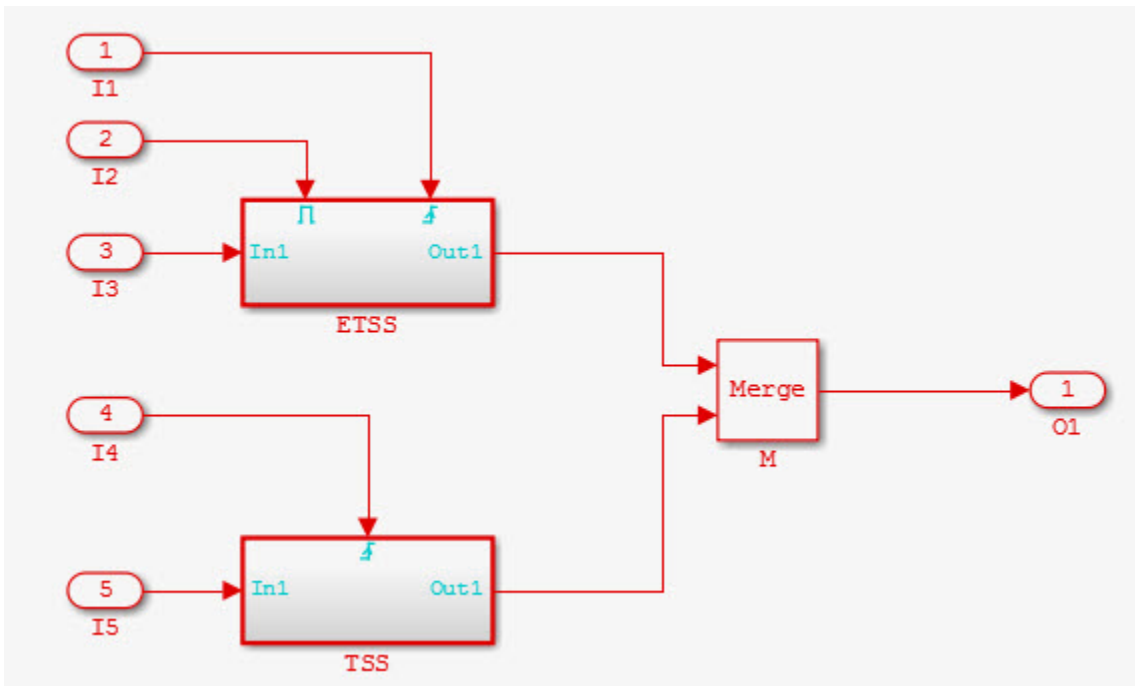

In R2015b, in the `removeflag.c` file, the code generator produced this code in the `removeflag_initialize` function:

```
/* InitializeConditions for Atomic SubSystem: '<Root>/SS' */
removeflag_SS_Init(removeflag_M, &removeflag_B.SS);

/* End of InitializeConditions for SubSystem: '<Root>/SS' */
```

The code for the `removeflag_SS_Init` function was as follows:

```
/* Initial conditions for atomic system: '<Root>/SS' */
void removeflag_SS_Init(RT_MODEL_removeflag_T * const removeflag_M,
    B_SS_removeflag_T *localB)
{
    /* InitializeConditions for Merge: '<S1>/M' */
    if (rtmIsFirstInitCond(removeflag_M)) {
        localB->M = 3.0;
    }
}
```

```
/* End of InitializeConditions for Merge: '<S1>/M' */
}
```

In R2015b, for the `removeflag_SS_Init` function, the generated code contained the `rtmIsFirstInitCond` flag.

In R2016a, in the `_sharedutils` folder, the code generator produces this reusable code:

```
/* System initialize for atomic system: 'SS' ('removeflagLib:1') */
void SS_bbDo8UEo_Init(B_SS_bbDo8UEo_T *localB)
{
    /* SystemInitialize for Merge: 'M' ('removeflagLib:11') */
    localB->M = 3.0;
}
```

The `removeflag.c` file contains a call to the `SS_bbDo8UEo_T_Init` function inside the `removeflag_initialize` function:

```
/* SystemInitialize for Atomic SubSystem: '<Root>/SS' */
SS_bbDo8UEo_Init(&removeflag_B.SS);

/* End of SystemInitialize for SubSystem: '<Root>/SS' */
```

The generated code does not contain the `rtmIsFirstInitCond` flag. Instead, the code generator generates reusable code for the `SS_bbDo8UEo_T_Init` function. The `rtmIsFirstInitCond` flag is not needed because the `model_Subsystem_Init` function initializes the states of blocks while the new reset function sets the states of all blocks back to their initial conditions.

## Optimized code for models containing logical operator blocks

In R2015b, for a model where an input signal fed into a Logical NOT block and either a Logical AND block or a Logical OR block, the generated code contained an expression for the Logical NOT and Logical AND or Logical OR blocks. In R2016a, the generated code sets the output equal to either true or false. This optimization simplifies the code and improves code efficiency.

For example, in the model `andornotself`, the input signal feeds into the Logical NOT block and the Logical AND block.

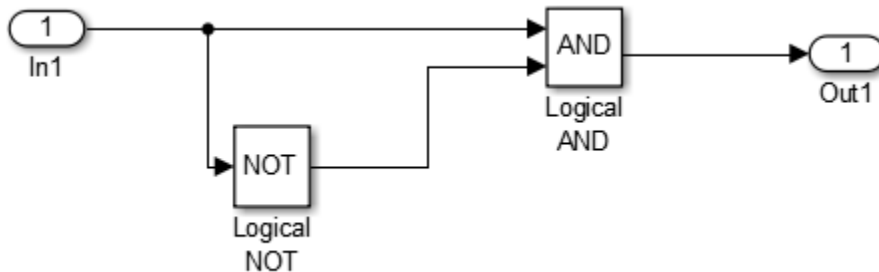

In R2015b, the generated code contained this code:

```

/* Model step function */
void andornotself_step(void)
{
  /* Outport: '<Root>/Out1' incorporates:
   * Inport: '<Root>/In1'
   * Logic: '<Root>/Logical AND'
   * Logic: '<Root>/Logical NOT'
   */
  andornotself_Y.Out1 = (andornotself_U.In1 && (!andornotself_U.In1));
}

```

In R2016a, the generated code contains this code:

```

/* Model step function */
void andornotself_step(void)
{
  /* Outport: '<Root>/Out1' */
  andornotself_Y.Out1 = false;
}

```

The optimized code sets `andornotself_Y.Out1` equal to `false` because the condition `andornotself_Y.Out1 = (andornotself_U.In1 && (!andornotself_U.In1))` is false.

## Improved code for conditional expressions involving Boolean expressions

In R2015b, for a model in which the generated code contained a conditional expression involving Boolean expressions, the generated code contained an `if-else` statement. In R2016a, the generated code uses `&&` and `||` operators to enable short-circuit evaluation. This optimization simplifies the code and improves code efficiency.

For example, the model `booleanConditionalExpr` contains two Inport blocks, a Switch block, a Constant block, and an Outport block. The Constant block has a value of `false`.

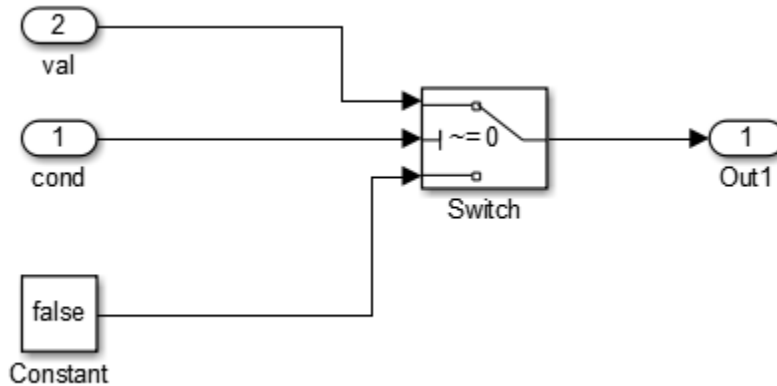

In R2015b, the code generator generated this code:

```

/* Model step function */
void booleanConditionalExpr_step(void)
{
  /* Switch: '<Root>/Switch' incorporates:
   * Inport: '<Root>/cond'
   */
  if (booleanConditionalExpr_U.cond) {
    /* Outport: '<Root>/Out1' incorporates:
     * Inport: '<Root>/val'
     */
    booleanConditionalExpr_Y.Out1 = booleanConditionalExpr_U.val;
  } else {
    /* Outport: '<Root>/Out1' incorporates:
     * Constant: '<Root>/Constant'
     */
    booleanConditionalExpr_Y.Out1 = false;
  }

  /* End of Switch: '<Root>/Switch' */
}

```

The generated code contained an `if-else` statement.

In R2016a, the code generator generates this code:

```
/* Model step function */
void booleanConditionalExpr_step(void)
{
    /* Outport: '<Root>/Out1' incorporates:
     * Inport: '<Root>/cond'
     * Inport: '<Root>/val'
     */
    booleanConditionalExpr_Y.Out1 = (booleanConditionalExpr_U.cond &&
        booleanConditionalExpr_U.val);
}
```

The generated code contains an `&&` expression. If `booleanConditionalExpr_U.cond` is false, the `&&` expression short-circuits and `booleanConditionalExpr_Y.Out1` is equal to false. Otherwise, `booleanConditionalExpr_Y.Out1` is equal to `booleanConditionalExpr_U.val`.

## memset Optimization for more scenarios

- “memset optimization for assigning a constant value to fields of a structure array” on page 3-44
- “memset optimization for array element assignments” on page 3-45
- “memset optimization for consecutive assignments that define a continuous write” on page 3-47

In R2015b, the code generator tried to replace a `for` loop that assigned a literal constant to consecutive array elements with a `memset` function call. A `memset` function call can be more efficient than `for`-loop controlled array element assignments.

In R2016a, the code generator attempts to invoke the `memset` optimization when assigning a constant value to all fields of a structure array. The code generator attempts to invoke the `memset` optimization for a loop with one or more array element assignments and for consecutive statements that define a continuous write.

---

**Note:** The minimum array size for which `memset` function calls can replace `for` loops depends on the setting of the **Memcpy threshold (bytes)** parameter. By default, this parameter specifies 64 bytes as the minimum array size for which `memset` function calls can replace `for` loops in the generated code.

---

### memset optimization for assigning a constant value to fields of a structure array

The following Simulink modeling pattern produces C code with a constant value assignment to fields of a structure array:

- The input to a MATLAB Function block is an array of buses. The bus elements are scalars.
- The MATLAB Function block contains a structure that writes the same value to each bus element.

In R2015b, for this modeling pattern, the generated code contained `for` loop controlled array element assignments. In R2016a, the code generator can replace these `for` loop controlled array element assignments with `memset` function calls. This optimization improves execution speed.

For example, in the following model, the input signal is an array of buses. The bus elements are the three scalars, `f1`, `f2`, and `f3`.

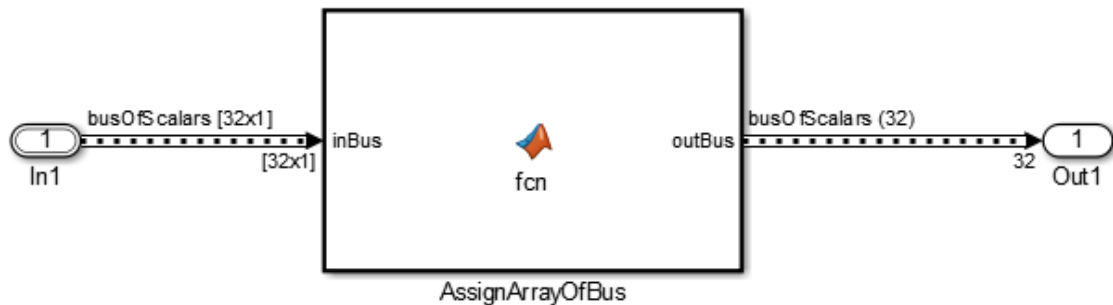

The MATLAB Function block contains this code:

```
function outBus = fcn(inBus)
%#codegen

for k = 1:24
    inBus(k).f1 = int32(0);
    inBus(k).f2 = int32(0);
    inBus(k).f3 = int32(0);
end
```

```

end

outBus=inBus;
end

```

In R2015b, the code generator produced this code:

```

/* MATLAB Function 'AssignArrayOfBus': '<S1>:1' */
/* '<S1>:1:4' for k = 1:24 */
for (k = 0; k < 24; k++) {
    /* '<S1>:1:5' inBus(k).f1 = int32(0); */
    inBus[k].f1 = 0;

    /* '<S1>:1:6' inBus(k).f2 = int32(0); */
    inBus[k].f2 = 0;

    /* '<S1>:1:7' inBus(k).f3 = int32(0); */
    inBus[k].f3 = 0;
}

/* '<S1>:1:10' outbus = inBus; */
memcpy(&localB->outBus[0], &inBus[0], sizeof(busOfScalars) << 5U);

```

The generated code contained a `for` loop for assigning a value of `int32(0)` to the structure fields, `f1`, `f2`, and `f3`.

In R2016a, the code generator produces this code:

```

/* MATLAB Function 'AssignArrayOfBus': '<S1>:1' */
/* '<S1>:1:4' for k = 1:24 */
/* '<S1>:1:5' inBus(k).f1 = int32(0); */
/* '<S1>:1:6' inBus(k).f2 = int32(0); */
/* '<S1>:1:7' inBus(k).f3 = int32(0); */
memset(&inBus[0], 0, 24U * sizeof(busOfScalars));

/* '<S1>:1:9' outBus=inBus; */
memcpy(&localB->outBus[0], &inBus[0], sizeof(busOfScalars) << 5U); }

```

The generated code contains a `memset` function call for assigning a value of `int32(0)` to the structure fields `f1`, `f2`, and `f3`.

### **memset optimization for array element assignments**

For a Simulink model containing a Bus Assignment block that accepts a bus signal consisting of arrays, the code generator produces C code with one or more array element

assignments. If the Bus Assignment block assigns values to a single array of the bus signal, the generated code contains one array element assignment. If the Bus Assignment block assigns values to arrays in the bus signal, there are multiple array element assignments. In R2015b, the generated code contained `for` loop controlled array element assignments. In R2016a, the code generator can replace these `for` loop controlled array element assignments with `memset` function calls. This optimization improves execution speed.

For example, in following model, the input signal is a `Simulink.Bus` object consisting of two arrays, `f1` and `f2`. The Bus Assignment block assigns a value of 0 to every element in `f1` and a value of 255 (`MAX_uint8_T`) to every element in `f2`.

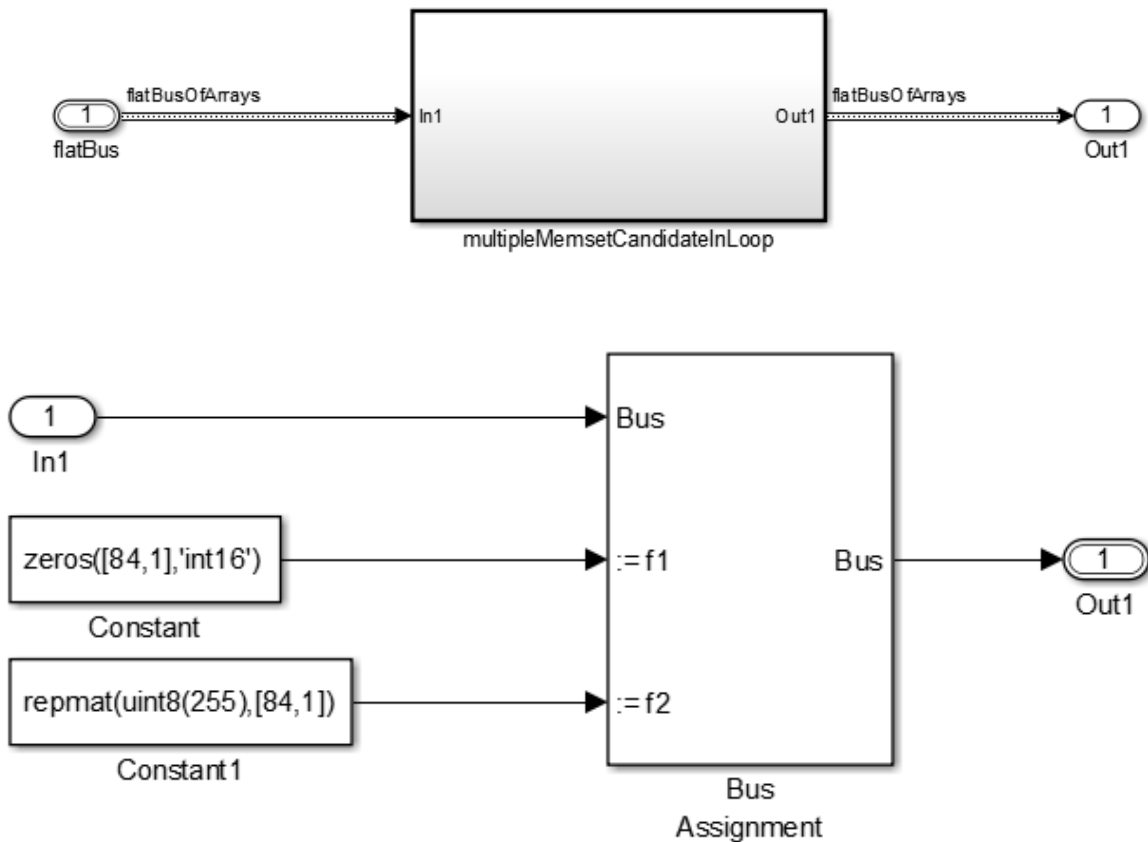



In R2015b, the code generator produced this code:

```
/* Model step function */
void memsetexample_step(void)
{
    int32_T i;

    /* Output: '<Root>/Out1' */
    for (i = 0; i < 84; i++) {
        memsetexample_Y.Out1.f1[i] = 0;
        memsetexample_Y.Out1.f2[i] = MAX_uint8_T;
    }

    /* End of Output: '<Root>/Out1' */
}
```

The generated code contained a `for` loop for assigning values to the arrays `f1` and `f2`.

In R2016a, the code generator produces this code:

```
/* Model step function */
void memsetexample_step(void)
{
    /* Output: '<Root>/Out1' */
    memset(&memsetexample_Y.Out1.f1[0], 0, 84U * sizeof(int16_T));
    memset(&memsetexample_Y.Out1.f2[0], 255, 84U * sizeof(uint8_T));
}
```

The generated code contains `memset` function calls for assigning values to `f1` and `f2`.

### **memset optimization for consecutive assignments that define a continuous write**

For a Simulink model containing a 1-D, 2-D, or multidimensional signal that feeds into an Assignment block, the code generator produces C code with consecutive array element assignments. In R2015b, if the following modeling conditions were met, the generated code contained multiple assignment statements:

- The Assignment block assigned a value of 0 to multiply elements of an output signal.
- In the generated code, the array size was below the value of the loop unrolling threshold parameter.

In R2016a, regardless of the value you set for the **Loop unrolling threshold** parameter, the code generator can replace these assignment statements with a `memset` function call. This optimization improves execution speed.

For example, in the Inport block parameters dialog box, the **Port Dimensions** parameter has a value of 128. The Assignment block assigns a value of 0 to the first 10 elements of this signal.

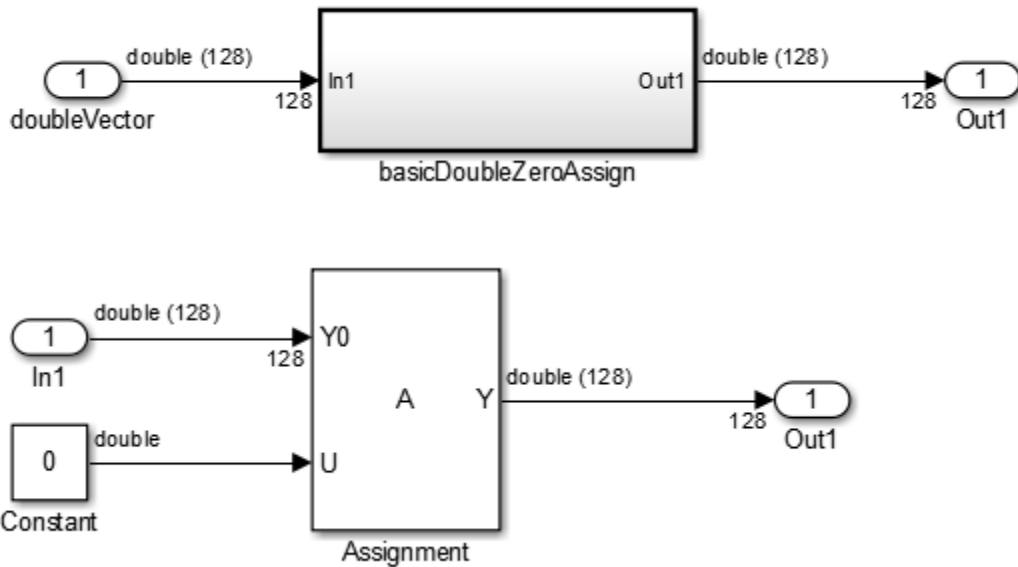

In R2015b, with a the code generator produced this code:

```
void memsetEx_basicDoubleZeroAssign(const real_T rtu_In1[128],
    B_basicDoubleZeroAssign_memse_T *localB)
{
    int32_T i;

    /* Assignment: '<S1>/Assignment' incorporates:
     * Constant: '<S1>/Constant'
     */
    memcpy(&localB->Assignment[0], &rtu_In1[0], sizeof(real_T) << 7U);
    localB->Assignment[0] = 0.0;
    localB->Assignment[1] = 0.0;
    localB->Assignment[2] = 0.0;
    localB->Assignment[3] = 0.0;
    localB->Assignment[4] = 0.0;
    localB->Assignment[5] = 0.0;
    localB->Assignment[6] = 0.0;
}
```

```

    localB->Assignment[7] = 0.0;
    localB->Assignment[8] = 0.0;
    localB->Assignment[9] = 0.0;
    /* End of Assignment: '<S1>/Assignment' */
}

```

The generated code contained individual write statements for assigning a value of 0 to the first 10 elements of the `Assignment` array.

In R2016a, the code generator produces this code:

```

void memsetEx_basicDoubleZeroAssign(const real_T rtu_In1[128],
    B_basicDoubleZeroAssign_memse_T *localB)
{
    /* Assignment: '<S1>/Assignment' incorporates:
     * Constant: '<S1>/Constant'
     */
    memcpy(&localB->Assignment[0], &rtu_In1[0], sizeof(real_T) << 7U);
    memset(&localB->Assignment[0], 0, 10U * sizeof(real_T));
}

```

The generated code contains a `memset` function call for assigning a value of 0 to the first 10 elements of the `Assignment` array.

## Changes to meaning of createCRLEntry wildcard syntax for fixed-point data

The meaning of wildcard symbols tilde (~) and asterisk (\*) in conceptual argument syntax specifications that you specify with the `createCRLEntry` function have changed.

Modified Syntax	Meaning Prior to R2016a	Meaning Starting with R2016a
Tilde symbol	Slopes must be the same across data types	Based on the position of the symbol, slopes or bias must be the same across data types
<code>fixdt(1,16,*) y1 = sin(fixdt(1,16,*) u1)</code> conceptual specification	Specify fixed-point data types and wildcard	Specify fixed-point data types and set <code>CheckSlope</code> to <code>false</code> and <code>CheckBias</code> to <code>true</code>
<code>fixdt(1,16,~) y1 = sin(fixdt(1,16,~)</code>	Not applicable	Specify fixed-point data types and set

Modified Syntax	Meaning Prior to R2016a	Meaning Starting with R2016a
u1) conceptual specification		SlopesMustBeTheSame to true, CheckSlope to false, and CheckBias to true
fixdt(1,16,~,~) y1 = sin(fixdt(1,16,~,~) u1) conceptual specification	Not applicable	Specify fixed-point data types and set SlopesMustBeTheSame to true, BiasMustBeTheSame to true, CheckSlope to false, and CheckBias to false
fixdt(1,16,*) y1 = fixdt(1,16,*) u1 + fixdt(1,16,*) u2 conceptual specification	Specify fixed-point data types and wildcard	Specify fixed-point data types and set CheckSlope to false and CheckBias to true

For more information, see the description of the createCRLEntry function.

## Code replacements involving root-level I/O variables and data alignment

The code generator does not replace functions that use root-level I/O variables or AUTOSAR inter-runnable access functions when it generates function code with C function prototype control, C++ class I/O arguments step method, or the AUTOSAR system target file.

If the following conditions exist, the code generator includes data alignment directives for root-level I/O variables in the example main program file (ert\_main.c or ert\_main.cpp) that it produces:

- Compiler supports global variable alignment
- Generate an example main program (select **Configuration Parameters > All Parameters > Generate an example main program**)
- Generate a reusable function interface for the model (set **Configuration Parameters > Code Generation > Interface > Code interface packaging** to Reusable function)
- Function uses root-level I/O variables that are passed in as individual arguments (set **Configuration Parameters > Code Generation > Interface > Pass root-level I/O** to Individual arguments)
- Replaced function uses a root-level I/O variable

- Replaced function imposes alignment requirements

If you discard the generated example main program, align used root-level I/O variables correctly.

If you choose not to generate an example main program in this case, the code generator does not replace the function.

For more information, see Code Replacement Customization Limitations.

## Verification

### **SIL/PIL Data Access: Use vector Get/Set custom storage class and C++ parameter access methods**

R2016a adds SIL and PIL support for data access capabilities:

- `GetSet` custom storage class support for vector signals and parameters. Previously, `GetSet` SIL and PIL support was available for scalar signals, parameters, and global data stores. For more information, see [Access Data Through Functions with Custom Storage Class GetSet](#).
- Simulation support for the `Method` and `Inlined` method options for the **Configuration Parameters > Code Generation > Interface > Parameter access** parameter. For more information, see [Control Generation of C++ Class Interfaces](#).

### **SIL/PIL support for variant condition propagation**

Model block SIL/PIL simulations support variant condition propagation with `Variant Source` and `Variant Sink` blocks.

Top-model SIL/PIL and SIL/PIL block simulations do not support the propagation of variant conditions across component boundaries.

### **SIL simulation returns standard output and standard error streams**

During a SIL simulation, the SIL application redirects the `stdout` and `stderr` streams. When the application terminates, the Diagnostic Viewer now displays the information from the redirected streams.

The SIL application also provides a basic signal handler, which captures the POSIX signals `SIGFPE`, `SIGILL`, `SIGABRT`, and `SIGSEV`. The SIL application includes the file `signal.h` for the signal handler.

The information from the redirected streams can help you to debug SIL applications that fail before the simulation is complete. For example, you can view:

- Output from `printf` statements in your code.
- Messages sent to `stderr`.

- Some low-level system messages.

For more information, see [Debug SIL Simulation](#).

## **Linux SIL/PIL support for LDRA Testbed**

For SIL and PIL simulations on Linux<sup>®</sup> systems, you can collect code coverage metrics by using LDRA Testbed<sup>®</sup> from LDRA Technology. For more information, see [Code Coverage Tool Support](#).

## Check bug reports for issues and fixes

Software is inherently complex and is not free of errors. The output of a code generator might contain bugs, some of which are not detected by a compiler. MathWorks reports critical known bugs brought to its attention on its Bug Report system at [www.mathworks.com/support/bugreports/](http://www.mathworks.com/support/bugreports/). Use the Saved Searches and Watched Bugs tool with the search phrase "Incorrect Code Generation" to obtain a report of known bugs that produce code that might compile and execute, but still produce wrong answers.

The bug reports are an integral part of the documentation for each release. Examine periodically all bug reports for a release, as such reports may identify inconsistencies between the actual behavior of a release you are using and the behavior described in this documentation.

In addition to reviewing bug reports, you should implement a verification and validation strategy to identify potential bugs in your design, code, and tools.



# R2015aSP1

Version: 6.8.1

Bug Fixes

## Check bug reports for issues and fixes

Software is inherently complex and is not free of errors. The output of a code generator might contain bugs, some of which are not detected by a compiler. MathWorks reports critical known bugs brought to its attention on its Bug Report system at [www.mathworks.com/support/bugreports/](http://www.mathworks.com/support/bugreports/). Use the Saved Searches and Watched Bugs tool with the search phrase "Incorrect Code Generation" to obtain a report of known bugs that produce code that might compile and execute, but still produce wrong answers.

The bug reports are an integral part of the documentation for each release. Examine periodically all bug reports for a release, as such reports may identify inconsistencies between the actual behavior of a release you are using and the behavior described in this documentation.

In addition to reviewing bug reports, you should implement a verification and validation strategy to identify potential bugs in your design, code, and tools.

# R2015b

**Version: 6.9**

**New Features**

**Bug Fixes**

**Compatibility Considerations**

## Code Generation from MATLAB Code

### **MATLAB Coder Storage Classes: Easily import and export data by using storage classes**

In R2015b, when you generate C/C++ code from MATLAB code, you can use a storage class to control the declaration and definition of a global variable in the generated code. Use of storage classes requires an Embedded Coder license.

In the context of code generation, a *storage class* is a specification that determines the declaration and definition of a variable in the generated code. For code generation, the term storage class is not the same as the C language term *storage class specifier*.

Storage classes help you to integrate generated code with external code. You can make a generated variable visible to external code. You can also make variables declared in the external code visible to the generated code. For code generation from MATLAB code, you can use storage classes with global variables only. The storage class determines:

- The file placement of a global variable declaration and definition.
- Whether the global variable is imported from external code or exported for use by external code.

To assign a storage class to a global variable, in your MATLAB code, use the `coder.storageClass` function. Only when you use an Embedded Coder project or configuration object for generation of C/C++ libraries or executables does the code generation software recognize `coder.storageClass` calls.

The syntax for `coder.storageClass` is:

```
coder.storageClass(var_name, storage_class)
```

`var_name` is the name of a global variable. Specify `var_name` as a constant string.

`storage_class` can be one of the following values:

- 'ExportedGlobal'
- 'ImportedExtern'
- 'ImportedExternPointer'

For descriptions of these storage classes, see [Storage Classes for Code Generation from MATLAB Code](#).

For example, `coder.StorageClass('g','ExportedGlobal')` assigns the exported global storage class to the global variable `g`.

For a detailed example, see [Control Declarations and Definitions of Global Variables in Code Generated from MATLAB Code](#).

If you do not assign a storage class to a global variable, the code generated for the variable is the same as the code generated in previous releases.

## **MATLAB Coder PIL With ARM Cortex-A: Verify and profile ARM optimized code with BeagleBone Black hardware**

In R2015b, you can use processor-in-the-loop (PIL) executions to verify generated code that you deploy to target hardware using a MATLAB Coder workflow with an Embedded Coder license. By using PIL with hardware, you can more effectively generate customized code for your hardware by profiling speed and algorithm performance. You have the option of using the command-line workflow or the MATLAB Coder app to configure your target hardware for PIL executions.

This PIL execution is available with the following hardware support packages:

- Embedded Coder Support Package for BeagleBone Black Hardware
- Embedded Coder Support Package for ARM Cortex-A Processors

To use this PIL execution, you must install one of these support packages. For more information, see:

- [PIL Execution with ARM Cortex-A at the Command Line](#)
- [PIL Execution with ARM Cortex-A by Using the MATLAB Coder App](#)

## **Code generation assumptions verified during PIL execution**

The settings on the **More Settings** > **Hardware** tab specify target behavior, which result in the implementation of implicit assumptions in the generated code. Incorrect settings can lead to:

- Suboptimal code
- Code execution failure, incorrect code output, and nondeterministic code behavior

At the start of a processor-in-the-loop (PIL) execution, the software verifies the **Hardware** tab settings with reference to the target hardware. The software checks:

- The correctness of settings. For example, the integer bit length in the **Sizes > int** field.
- Whether the settings are optimized. For example, the rounding of signed integer division in the **Signed integer division rounds to** field.

If required, the software generates warnings and errors.

## Control of signed right shifts in generated code

You can now control the use of signed right shifts in your generated code. Some coding standards do not allow bitwise operations on signed integers. Disabling the use of signed shifts in generated code increases the likelihood of compliance with MISRA. When you specify that signed right shifts should not be used in your generated code, the software replaces signed shifts with a call to a function that performs the operation without the use of signed shifts.

To specify that MATLAB Coder not use signed right shifts:

- Using the MATLAB Coder app:
  - 1 On the **Generate Code** page, to open the **Generate** dialog box, click the **Generate** arrow .
  - 2 Set **Build type** to one of the following:
    - Source Code
    - Static Library (.lib)
    - Dynamic Library (.dll)
    - Executable (.exe)
  - 3 Click **More Settings**.
  - 4 On the **Code Appearance** tab, clear the **Allow right shifts on signed integers** check box.
- Using the command-line interface:
  - 1 Create a code configuration object for 'lib', 'dll', or 'exe'.

```
cfg = coder.config('lib','ecoder',true); % or dll or exe
```
  - 2 Set the `EnableSignedRightShifts` property to `false`.

```
cfg.EnableSignedRightShifts = false;
```

## Detection of multiword operations

When an operation has an input or output larger than the largest word size of your processor, the generated code contains multiword operations. Multiword operations can be inefficient on hardware. The expensive fixed-point operations check now highlights expressions in your MATLAB code that could result in multiword operations in generated code. For more information on this check, see [Find and Address Multiword Operations](#).

## Model Architecture and Design

### MISRA-C 2012: Comply with mandatory and required rules

Model Advisor checks support compliance with MISRA C:2012. Previously, Model Advisor checks supported compliance with MISRA C:2004. To check that you developed your model or subsystem to increase the likelihood of generating MISRA C:2012 compliant code:

- 1 Open the Model Advisor.
- 2 Navigate to **By Task > Modeling Guidelines for MISRA C:2012**.
- 3 Run the checks in the folder.

The following table summarizes the check changes. For information about MISRA C versions and updates, see MISRA C Guidelines.

Check	Update	Addresses
Check configuration parameters for MISRA C:2012	Renamed from <b>Check configuration parameters for MISRA-C:2004 compliance</b>	MISRA C:2012
Check for blocks not recommended for MISRA C:2012	Renamed from <b>Check for blocks not recommended for MISRA-C:2004 compliance</b>	MISRA C:2012
Check for bitwise operations on signed integers	None	MISRA C:2012, Dir 10.1
Check for recursive function calls	New	MISRA C:2012, Dir 17.2
Check for equality and inequality operations on floating-point values	New	MISRA C:2012, Dir 1.1
Check for switch case expressions without a default case	New	MISRA C:2012, Rule 16.4



## **AUTOSAR 4.1.3 and 4.2: Import and export ARXML and generate code for latest AUTOSAR standard**

R2015b extends AUTOSAR schema support to schema 4.2 (revision 4.2.1) and schema 4.1 (revision 4.1.3). For a detailed list of AUTOSAR schemas supported for import and export of arxml files and generation of AUTOSAR-compatible C code, see Select an AUTOSAR Schema.

R2015b provides many other enhancements to Simulink modeling of AUTOSAR elements and AUTOSAR code generation. For more information, see:

- Under Model Architecture and Design:
  - “AUTOSAR sender-receiver modeling” on page 5-7
  - “AUTOSAR client-server modeling” on page 5-10
  - “AUTOSAR nonvolatile data communication modeling” on page 5-12
  - “AUTOSAR component behavior modeling” on page 5-14
  - “AUTOSAR COM\_AXIS lookup table modeling” on page 5-15
- Under Code Generation:
  - “AUTOSAR arxml round-trip” on page 5-21
  - “Toolchain controls for AUTOSAR code generation” on page 5-24
  - “AUTOSAR RTE file generation enhanced for SIL and PIL” on page 5-24
  - “Lookup table blocks with new even spacing specification generate AUTOSAR compatible IFX library routines” on page 5-26

## **AUTOSAR sender-receiver modeling**

R2015b enhances AUTOSAR sender-receiver modeling with support for:

- `IsUpdated` API for receiver ports
- Data element invalidation policies on sender ports
- End-to-end protection for sender and receiver ports
- `DataReceiveErrorEvent` for receiver ports
- `Rte_IWriteRef` for sender ports

### **IsUpdated API for receiver ports**

AUTOSAR defines quality of service attributes, such as `ErrorStatus` and `IsUpdated`, for sender-receiver interfaces. R2015b adds support for the AUTOSAR `IsUpdated` attribute and API. The `IsUpdated` attribute allows an AUTOSAR receiver to detect when a receiver port data element has received data since the last read occurred. When data is idle, the receiver can save computational resources. You can:

- Import an AUTOSAR receiver port for which `IsUpdated` service is configured.
- Use Simulink to configure an AUTOSAR receiver port for `IsUpdated` service.
- Generate C and `arxml` code for an AUTOSAR receiver port for which `IsUpdated` service is configured.

For more information, see [Configure AUTOSAR Receiver Port for IsUpdated Service](#).

### **Data element invalidation policies on sender ports**

AUTOSAR defines an invalidation mechanism for data elements on AUTOSAR sender ports. To protect downstream data consumers from receiving invalid data, you can define an invalidation policy for a sender port data element. R2015b adds support for data element invalidation policies on sender ports. You can:

- Import AUTOSAR sender port data elements for which an invalidation policy is configured.
- Use Simulink to configure an invalidation policy for AUTOSAR sender port data elements.
- Generate C and `arxml` code for AUTOSAR sender port data elements for which an invalidation policy is configured.

For more information, see [Configure AUTOSAR Sender Port for Data Element Invalidation](#).

### **End-to-end protection for sender and receiver ports**

AUTOSAR end-to-end (E2E) protection for sender and receiver ports is based on the E2E library. E2E is a C library that you can use to transmit data securely between AUTOSAR components. End-to-end protection adds additional information to an outbound data packet. The component receiving the packet can then verify independently that the received data packet matches the sent packet. Potentially, the receiving component can detect errors and take action.

For easier integration of AUTOSAR generated code with AUTOSAR E2E solutions, R2015b adds support for AUTOSAR E2E protection. You can:

- Import AUTOSAR sender port and receiver ports for which E2E protection is configured.
- Use Simulink to configure an AUTOSAR sender or receiver port for E2E protection.
- Generate C and arxml code for AUTOSAR sender and receiver ports for which E2E protection is configured.

For more information, see [Configure AUTOSAR S-R Interface Port for End-To-End Protection](#).

### **DataReceiveErrorEvent for receiver ports**

In AUTOSAR sender-receiver communication between software components, the run-time environment (RTE) raises a `DataReceiveErrorEvent` when the communication layer reports an error in data reception by the receiver component. For example, the event can indicate that the sender component failed to reply within an `aliveTimeout` limit, or that the sender component sent invalid data.

R2015b adds support for creating `DataReceiveErrorEvents` in AUTOSAR receiver components. You can:

- Import an AUTOSAR `DataReceiveErrorEvent` definition.
- Use Simulink to define a `DataReceiveErrorEvent`.
- Generate arxml code for AUTOSAR receiver ports for which a `DataReceiveErrorEvent` is configured.

For more information, see [Configure AUTOSAR Receiver Port for DataReceiveErrorEvent](#).

### **Rte\_IWriteRef for sender ports**

In R2015b, you can leverage the `Rte_IWriteRef` API (AUTOSAR Release 4.x) when writing to AUTOSAR sender ports. `Rte_IWriteRef` returns a reference to the write data, which the runnable code can use to directly update the corresponding data elements. The API provides constant execution time for writes of any data element type, including structure and matrix data.

If you want AUTOSAR sender port data to be written using `Rte_IWriteRef` rather than `Rte_IWrite`, configure the corresponding Simulink root output for `ImplicitSendByRef` access. For example, suppose that you open the example model

rtwdemo\_autosar\_counter, and change the data access mode of its root output, Output, from ImplicitSend to ImplicitSendByRef.

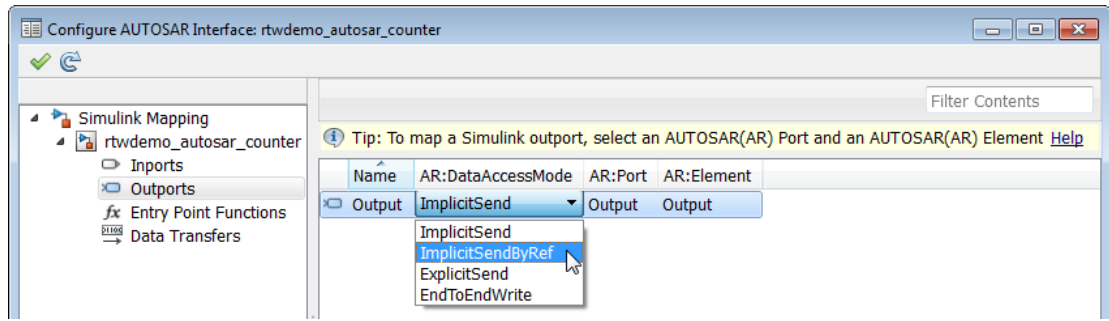

When you generate code, in `rtwdemo_autosar_counter.c`, the model step function uses `Rte_IWriteRef` to write the sender port data.

```
void Runnable_Step(void)
{
    ...
    int32_T *tmp;
    tmp = Rte_IWriteRef_Runnable_Step_Output_Output();
    ...
    /* Output: '<Root>/Output' incorporates:
     * Gain: '<S1>/Gain'
     * Inport: '<Root>/Input'
     */
    ...
    *tmp = Rte_Prm_rCounter_K() * Rte_IRead_Runnable_Step_Input_Input();
    ...
}
```

## AUTOSAR client-server modeling

R2015b enhances AUTOSAR client-server modeling with support for:

- AUTOSAR error status
- AUTOSAR NVRAM memory services

### AUTOSAR error status

In R2015b, you can model AUTOSAR application error status for client-server error handling. In Simulink, you can:

- Import `arxml` code that implements client-server error handling.
- Configure error handling for a client-server interface.

- Generate C and arxml code for client-server error handling.

For more information, see [Configure AUTOSAR Client-Server Error Handling](#).

### AUTOSAR NVRAM memory services

R2015b provides improved support for AUTOSAR nonvolatile RAM memory (NvM) services, including the NvM APIs `ReadBlock`, `WriteBlock`, and `RestoreBlockDefaults`. On ECU hardware startup or shutdown, or in response to an explicit read or write request, NvM services store data needed by the AUTOSAR software component. To better support NvM services, Embedded Coder:

- Imports and exports the `void` pointer data type that the NvM APIs use.
- Imports and exports asynchronous-server call points for calling the NvM APIs. The `arxml` importer creates Function Caller blocks to model the call points.
- Enforces constraints for modeling the RAM block required for NvM API calls. A data store memory block models the RAM block, and must directly connect to the Function Caller block.
- Generates C code that provides the RAM block to the NvM API calls without creating a local buffer.

Here is an example of Data Store Read and Function Caller blocks that model an asynchronous call to the NvM `WriteBlock` service.

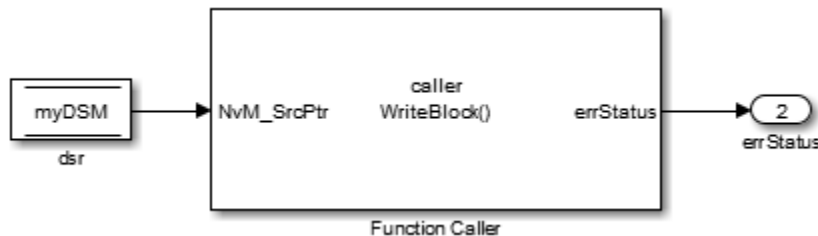

The generated C code calls the NvM `WriteBlock` service with the global RAM block as an argument.

```
appErrType = Rte_Call_WriteBlock_client_WriteBlock(Rte_Pim_myDSM());
```

## Compatibility Considerations

Enforcing the new modeling constraints can generate errors for models that previously did not get errors. For example, if a Function Caller block configured to call an

AUTOSAR NvM API does not directly connect to a data store block, Embedded Coder generates an error.

## AUTOSAR nonvolatile data communication modeling

In R2015b, you can model AUTOSAR nonvolatile (NV) data communication, as defined in AUTOSAR Release 4.0 or later. To implement NV data communication, AUTOSAR software components define provide and require ports that send and receive NV data. In Simulink, you can:

- Import AUTOSAR NV data communication definitions from `arxml` code.
- Create AUTOSAR NV data communication elements, including an NV interface and ports, and map Simulink inports and outports to AUTOSAR NV ports.
- Generate C and `arxml` code for AUTOSAR NV data communication elements.

To create NV data communication elements in Simulink:

- 1 Open the Configure AUTOSAR Interface dialog box and select **AUTOSAR Properties**.
- 2 Select **NV Interfaces**. Click the **Add** icon  to create a new NV data interface. Specify its name and the number of associated NV data elements.
- 3 Select and expand the new NV interface. Select **Data Elements**, and modify the data element attributes.

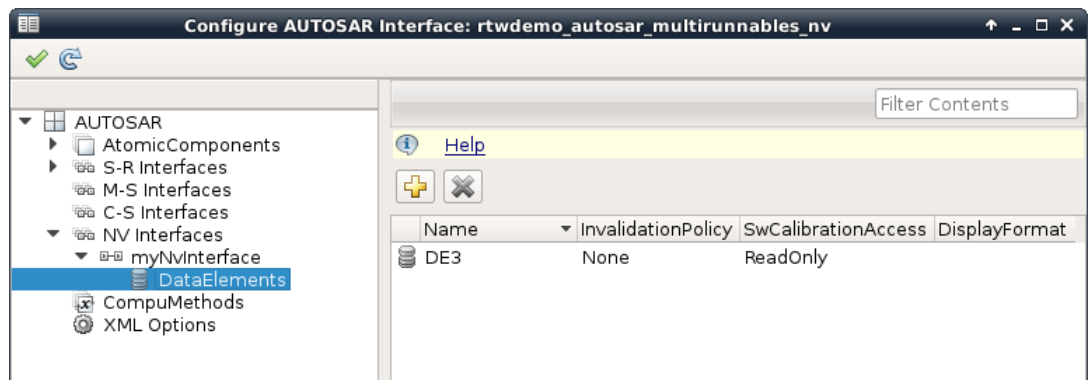

- 4 In the left-hand pane of the Configure AUTOSAR Interface dialog box, under **AUTOSAR**, select **AtomicComponents**. Expand **AtomicComponents** and select an AUTOSAR component. Expand the component.

- 5 Select and use the **NvReceiverPorts**, **NvSenderPorts**, and **NvSenderReceiverPorts** views to add the NV ports you require. For each NV port, select the NV interface you created.

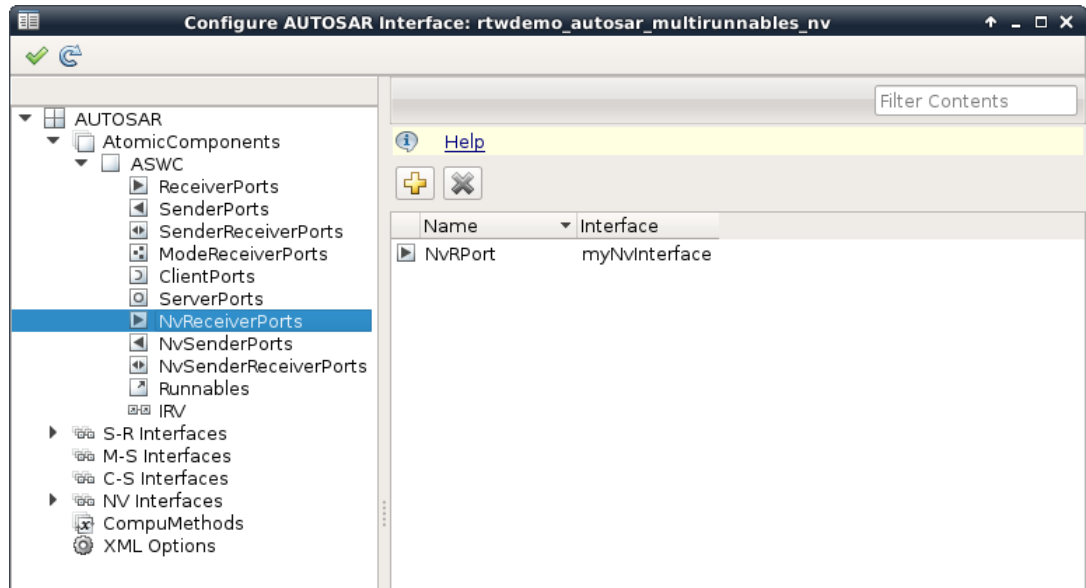

- 6 Switch to the Simulink mapping view. Select **Simulink-AUTOSAR Mapping**.
- 7 Select and use the **Inports** and **Outports** views to map Simulink inports and outports to AUTOSAR NV ports. For each inport or outport, select an AUTOSAR port, data element, and data access mode.

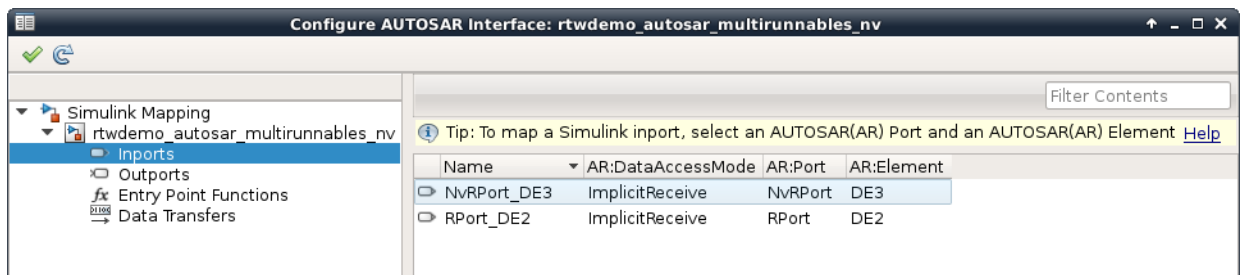

To programmatically configure AUTOSAR NV data communication elements, use the AUTOSAR property and mapping functions. For example, the following MATLAB code

adds an AUTOSAR NV data interface and an NV receiver port to an open model. It then maps a Simulink inport to the AUTOSAR NV receiver port.

```
% Add AUTOSAR NV data interface myNvInterface with NV data element DE3
arProps = autosar.api.getAUTOSARProperties('rtwdemo_autosar_multirunnables_nv');
addPackageableElement(arProps,'NvDataInterface','/pkg/if','myNvInterface');
add(arProps,'myNvInterface','DataElements','DE3');

% Add AUTOSAR NV receiver port NvrRPort, associated with myNvInterface
add(arProps,'ASWC','NvReceiverPorts','NvrRPort','Interface','myNvInterface');

% Map Simulink inport NvrRPort_DE3 to AUTOSAR port/element pair NvrRPort and DE3
slMap = autosar.api.getSimulinkMapping('rtwdemo_autosar_multirunnables_nv');
mapInport(slMap,'NvrRPort_DE3','NvrRPort','DE3','ImplicitReceive');
```

## AUTOSAR component behavior modeling

R2015b enhances AUTOSAR component behavior modeling with support for:

- IRVs in feedback loops
- Constant memory with `const` or `volatile` type qualifiers

### IRVs in feedback loops

Simulink modeling now supports an AUTOSAR inter-runnable feedback loop, that is, AUTOSAR runnables accessing an AUTOSAR inter-runnable variable (IRV) with both read and write access. For example, in the figure, Runnable2\_subsystem can read and write `irv1`. (Signal `irv1` is shown in **Highlight Signal to Source** view.) In previous releases, the software flagged an error for this modeling pattern.

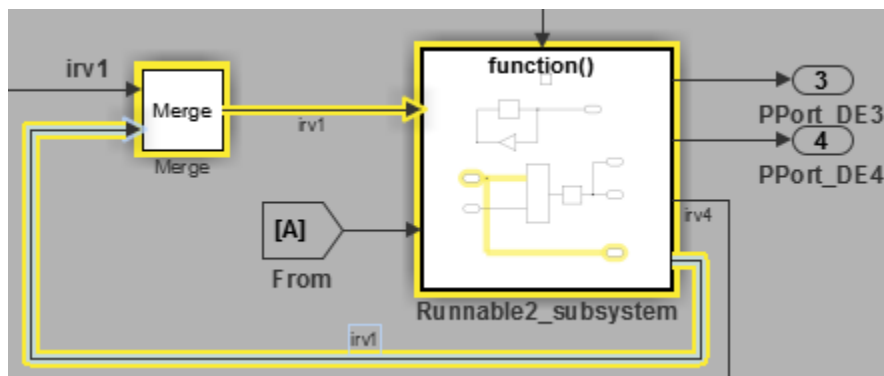



## Constant memory with `const` or `volatile` type qualifiers

When modeling an AUTOSAR constant or static memory variable (AUTOSAR schema 4.x), you can now generate `const`, `volatile`, or `const volatile` qualifiers in C code to control data access.

You model AUTOSAR constant memory and static memory using `AUTOSAR4.Parameter` and `AUTOSAR4.Signal` data objects with a global storage class. Optionally, you can create custom storage classes and memory sections to customize the code generated for the global memory data, as described in [Design Custom Storage Classes and Memory Sections](#). The AUTOSAR4 data class package now provides `CONST`, `VOLATILE`, and `CONST_VOLATILE` memory section definitions for configuring the `const`, `volatile`, and `const volatile` qualifiers. You can reference the new memory-section values in `cscdesigner` to set up memory sections, and then reference the values from within `AUTOSAR4.Parameter` and `AUTOSAR4.Signal` data objects.

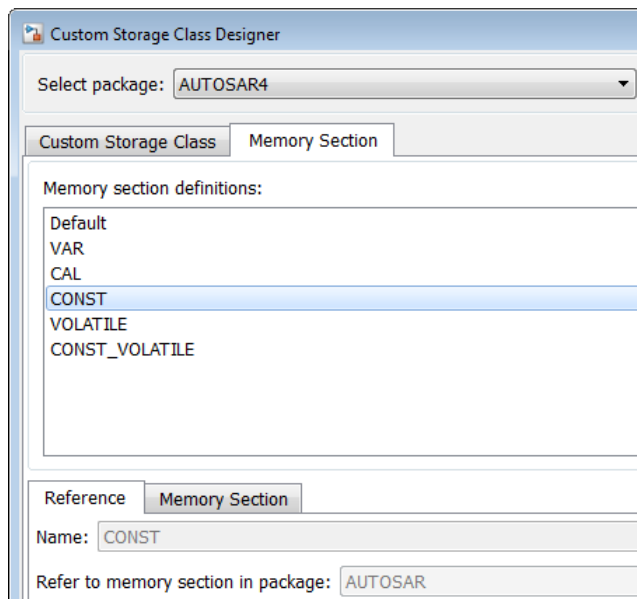

## AUTOSAR `COM_AXIS` lookup table modeling

R2015b provides the ability to model common axis (`COM_AXIS`) lookup tables for AUTOSAR applications. You can:

- Import AUTOSAR calibration parameters of category CURVE, MAP, CUBOID, and COM\_AXIS from arxml files into Simulink. The importer creates corresponding model content, including n-D Lookup Table blocks and parameter objects.
- Use Simulink to create a COM\_AXIS table and configure it for AUTOSAR run-time calibration.
- Export COM\_AXIS lookup table information in arxml code, including calibration parameters of category CURVE, MAP, CUBOID, and COM\_AXIS.

For more information, see Calibration Parameters for COM\_AXIS Lookup Tables and Configure COM\_AXIS Lookup Table for Measurement and Calibration.

## Embedded Coder model templates

In R2015b, Embedded Coder templates provide you with a starting point for quickly developing models for code generation. Embedded Coder templates provide starting models for the following applications:

- Code Generation System. Create a model to get started with code generation.
- Exported functions. Create a model for generating code from function-call subsystems.
- Fixed-step, multirate. Create a fixed-step model with multiple rates for production code generation.
- Fixed-step, single-rate. Create a fixed-step model with a single rate for production code generation.

In the templates, traceability and reporting are turned on so that you can easily evaluate your generated code. The model configuration settings are based on code generation objectives for execution efficiency and traceability.

For more information on using the templates, see Create a Model Configured for Code Generation Using Embedded Coder Templates.

## Removal of uncalled `Disable` functions from generated code

In R2015a, the code generator created `Disable` functions that the generated code did not call. In R2015b, the code generator does not create uncalled `Disable` functions, except in the following cases:

- A model containing a Model Reference block or an S-function block.
- You are exporting code for a function-call subsystem.

In these cases, the code generator creates `Disable` functions that the generated code might not call. The code generator does not have enough information to determine whether the generated code requires the `Disable` functions.

This enhancement reduces code size and ROM consumption.

## Enhancement to option for generating preprocessor conditionals

Previously, the **Code Generation > Interface** pane of the Model Configuration Parameters dialog box contained the option to **Generate preprocessor conditionals**. When you set this option to `Enable all` or `Disable all`, the global setting overrode the local setting **Generate preprocessor conditionals** that you specified on Variant Subsystem or Variant Model blocks.

In R2015b, the following enhancements have been made to the **Generate preprocessor conditionals** option.

- The option is now local to Variant Subsystem and Variant Model blocks. The global option has been removed from the Model Configuration Parameters dialog box. This enhancement eliminates the confusion regarding which option, global or local, is active.
- When you select this option, Simulink analyzes variant choices during an update diagram or simulation. This analysis provides early validation of the code generation readiness of variant choices.
- The Model Advisor now includes a check to identify models whose global **Generate preprocessor conditionals** option is set to `Enable all` or `Disable all`. The check provides instructions on how to migrate the global setting to individual variant blocks.

## Compatibility Considerations

- Previously, when the **Generate preprocessor conditionals** option was switched on, Simulink analyzed variant choices only during the code generation phase. Now, Simulink performs this analysis during the update diagram phase. As a result, errors that you would normally see during code generation appear earlier, during an update diagram.
- If you load a pre-R2015b model whose global **Generate preprocessor conditionals** option was set to `Enable all` or `Disable all`, Embedded Coder generates a warning. The warning contains instructions on how to migrate the global setting to

individual variant blocks. After the migration is complete, the affected variant blocks behave as they did in previous releases.

## Data, Function, and File Definition

### Tokenized function names for custom storage class `GetSet`

When you apply the custom storage class `GetSet` to a signal, block parameter, or state, you specify the names of functions to read or write the data in the generated code. In R2015b, when you identify these function names by specifying the properties `GetFunction` and `SetFunction`, you can use the token `$N`. The generated code calls the functions that you specify by replacing the token with the name of the signal, parameter, or state.

For example, if you specify the property `GetFunction` as `get_$N_data` for a signal named `mySig`, the generated code calls the function `get_mySig_data` to access the signal.

When you apply the custom storage class `GetSet` to new signals, parameters, or states, the default `GetFunction` value is `get_$N`, and the default `SetFunction` value is `set_$N`.

For more information, see [Access Data Through Functions with Custom Storage Class `GetSet`](#).

## Code Generation

### **Embedded Coder Quick Start: Quickly configure model to generate reusable and efficient code**

The Embedded Coder Quick Start tool helps you quickly generate readable, efficient code from your Simulink model. To start the tool, from the model window, select **Code > C/C+ > Embedded Coder Quick Start**.

You must select preferences about your code generation objectives and target environment. The tool then validates your choices against the model and presents the parameter changes required to generate code. If you choose to generate code, the tool executes the changes to your configuration set and generates the code.

When code generation is complete, links to the documentation present possible next steps, such as customizing your generated code and refining code optimizations.

For more information, see [Generate Code with the Embedded Coder Quick Start Tool](#).

### **Internationalization: Generate and review code containing mixed languages for different locales**

In R2015b, the code generator introduces support for non-US-ASCII characters in compilable portions of generated source code. The code generator processes strings without loss of information or character corruption by replacing unrepresented characters of the user default encoding with an escape sequence of the form `&#xcode-unit`; `code-unit` is the hexadecimal value for the unrepresented character. For example, the code generator replaces the Japanese full-width Katakana letter `㍻` with the escape sequence `&#x30A2`; . Cases where escape sequence replacements occur include:

- Strings representing model parameters, block names, and signal names that appear in generated code comments.
- Output variables representing signal names and block names on block paths logged to MAT- files.
- Variables representing block names on block paths logged to C API files `model_capi.c` (or `.cpp`) and `model_capi.h`.

When generating HTML code reports, the code generator converts replacement character escape sequences with original strings to preserve model-to-code traceability.

Two exceptions to the character escape sequence replacement scheme are:

- Comments in code generation template (.cgt) files
- Variables and function names in Target Language Compiler (.t1c) files

By default, code generation template files do not contain encoding information. The operating system reads the files in the user default encoding, regardless of the encoding that you use to write the file. You can enable escape sequence replacements by adding the following token to your template file:

```
<encodingIn = "encoding">
```

Replace *encoding* with a string that names a standard character encoding scheme, such as UTF-8, ISO-8859-1, or windows-1251.

Target Language Compiler files support user default encoding only. To use the compiler to produce international custom generated code that is portable, use the 7-bit ASCII character set when naming variables and functions.

For more information, see Internationalization and Code Generation.

## MISRA C:2012 code generation objective

The Code Generation Advisor includes a new objective for MISRA C:2012 guidelines. Setting the objective increases the likelihood of generating MISRA C:2012 compliant code. The MISRA C:2012 guideline objective replaces the MISRA-C:2004 guideline.

For more information, see Configure Model for Code Generation Objectives Using Code Generation Advisor.

### Compatibility Considerations

The MISRA C:2012 guideline objective replaces the MISRA-C:2004 guideline. If you use the command-line to set the `ObjectivePriorities` parameter to `MISRA-C:2004` guideline, Embedded Coder will use the `MISRA C:2012 guideline` objective.

## AUTOSAR arxml round-trip

R2015b enhances the AUTOSAR arxml round-trip workflow with support for:

- Editable AUTOSAR display format for calibration
- Configurable export of AUTOSAR internal data constraints
- AUTOSAR reference bases
- AUTOSAR-typed per-instance memory import

### **Editable AUTOSAR display format for calibration**

AUTOSAR display format specifications control the width and precision display for calibration and measurement data. In R2015b, you can import and export AUTOSAR display format specifications, and edit the specifications in Simulink. You can specify display format for the following AUTOSAR data objects and elements:

- Signal and parameter data objects (AUTOSAR and AUTOSAR4 classes)
- Inter-runnable variables
- Sender-receiver interface data elements
- Client-server interface operation arguments
- CompuMethods

For more information, see [Configure AUTOSAR Display Format for Measurement and Calibration](#).

### **Configurable export of AUTOSAR internal data constraints**

In releases before R2015b, you could not control the export or packaging of AUTOSAR internal data constraints from Simulink. Code generation exported internal data constraints to AUTOSAR package `DataConstrs` at a fixed location under the AUTOSAR datatype package.

In R2015b, you can enable or disable export of AUTOSAR internal data constraints. Export now is disabled by default. Optionally, you can specify the name and path of an AUTOSAR package into which internal data constraints are exported. For more information, see [Configure AUTOSAR Internal Data Constraints Export](#).

### **AUTOSAR reference bases**

Embedded Coder now can import AUTOSAR reference bases from `arxml` code into a model. Reference bases, which are defined in AUTOSAR Release 4.0, allow the use of relative paths in AUTOSAR specifications of packageable elements. In this `arxml`



code example, reference base CMs resolves to /pkg/Components/MyComponent/CompuMethods.

```

<REFERENCE-BASES>
  <REFERENCE-BASE>
    <SHORT-LABEL>MyComponent</SHORT-LABEL>
    <IS-DEFAULT>>true</IS-DEFAULT>
    <PACKAGE-REF DEST="AR-PACKAGE">
      /pkg/Components/MyComponent
    </PACKAGE-REF>
  </REFERENCE-BASE>
  <REFERENCE-BASE>
    <SHORT-LABEL>IFs</SHORT-LABEL>
    <IS-DEFAULT>>false</IS-DEFAULT>
    <PACKAGE-REF BASE="MyComponent" DEST="AR-PACKAGE">
      PortInterfaces
    </PACKAGE-REF>
  </REFERENCE-BASE>
  <REFERENCE-BASE>
    <SHORT-LABEL>CMs</SHORT-LABEL>
    <IS-DEFAULT>>false</IS-DEFAULT>
    <PACKAGE-REF BASE="myComponent" DEST="AR-PACKAGE">
      CompuMethods
    </PACKAGE-REF>
  </REFERENCE-BASE>
</REFERENCE-BASES>
<APPLICATION-PRIMITIVE-DATA-TYPE>
  <SHORT-NAME>t_bool_OneToOne</SHORT-NAME>
  <CATEGORY>VALUE</CATEGORY>
  <SW-DATA-DEF-PROPS>
    ...
    <SW-CALIBRATION-ACCESS>NOT-ACCESSIBLE</SW-CALIBRATION-ACCESS>
    <COMPU-METHOD-REF BASE="CMs" DEST="COMPU-METHOD">
      OneToOne
    </COMPU-METHOD-REF>
    ...
  </SW-DATA-DEF-PROPS>
</APPLICATION-PRIMITIVE-DATA-TYPE>

```

Resolves to /pkg/Components/MyComponent/PortInterfaces

Resolves to /pkg/Components/MyComponent/CompuMethods

### AUTOSAR-typed per-instance memory import

R2014a introduced modeling and code generation support for AUTOSAR-typed per-instance memory (arTypedPerInstanceMemory) in Simulink models. With R2015b, you can import arTypedPerInstanceMemory definitions from arxml code into a model. When you import an arTypedPerInstanceMemory definition, the arxml importer:

- Creates an `AUTOSAR.Signal` data object, sets its **Storage class** to `PerInstanceMemory`, and configures per-instance memory attributes.
- Creates a Data Store Memory block that references the `AUTOSAR.Signal` object.

For more information, see [Per-Instance Memory and Configure AUTOSAR Per-Instance Memory](#).

## Toolchain controls for AUTOSAR code generation

The AUTOSAR target (`autosar.tlc`) now supports toolchain controls for C code generation. When you select the AUTOSAR target, the Configuration Parameter dialog box displays toolchain parameters rather than the template makefile (TMF) parameters previously displayed. You can more flexibly configure AUTOSAR code generation, for example, for processor-in-the-loop (PIL) verification, or to leverage a toolchain-based hardware support package.

The screenshot shows a configuration dialog for the AUTOSAR target. It includes fields for 'System target file' (autosar.tlc), 'Language' (C), and 'Description' (AUTOSAR). The 'Build process' section contains 'Toolchain settings' with a dropdown for 'Toolchain' (GNU Tools for ARM Embedded Processors) and a 'Build configuration' dropdown (Faster Builds). A 'Show settings' link is present next to the build configuration dropdown, and a note below it reads 'Minimize compilation and linking time'.

Other targets that support toolchain controls include the ERT targets `ert.tlc` and `ert_shrllib.tlc`.

## AUTOSAR RTE file generation enhanced for SIL and PIL

Building an AUTOSAR model generates RTE (run-time environment) files into the `stub` subfolder of the model build folder. The RTE files have `.c` and `.h` extensions, and contain stub implementations of the AUTOSAR `Rte` functions. The stub implementations can be used to test the generated C code in Simulink, for example, in software-in-the-loop (SIL) or processor-in-the-loop (PIL) simulations of the component under test. When the

generated code ultimately is deployed in the AUTOSAR RTE, you replace the RTE stub files with externally-generated RTE files.

R2015b enhances the generated RTE stub files in many respects. The build generates most of the same RTE stub files as before, but with improved content:

- More closely reflects the AUTOSAR element content of the model.
- More closely resembles what an external RTE Generator creates.
- Better descriptions of content and possible uses.

R2015b also generates new stub files, `Std_Types.h`: and `Platform_Types.h`:

- `Std_Types.h` is a standard AUTOSAR file that defines basic data types.
- `Platform_Types.h` maps AUTOSAR base types to platform types.
- `Std_Types.h` includes `Platform_Types.h`, and is included by `Rte_Type.h`.

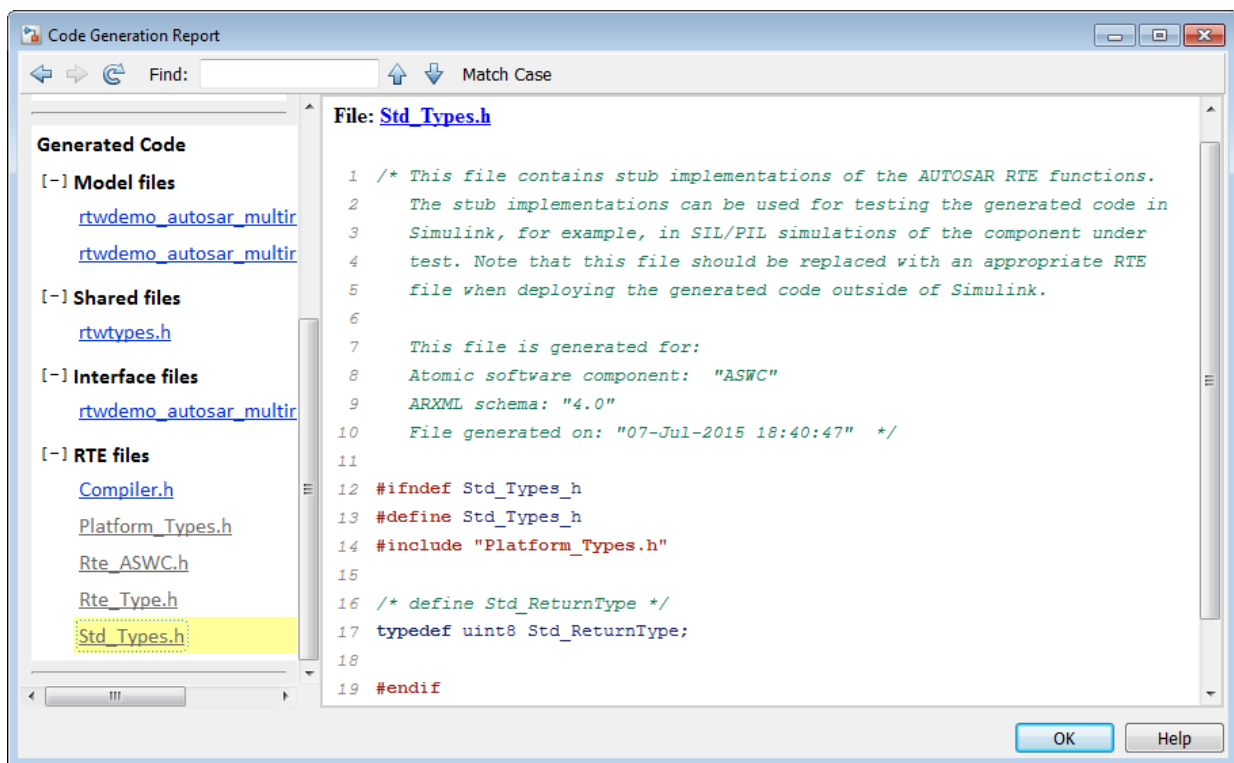

## Lookup table blocks with new even spacing specification generate AUTOSAR compatible IFX library routines

As of R2015b, lookup table blocks generate AUTOSAR compatible IFX library routines. Lookup table blocks were enhanced to support a new specification for even-spacing breakpoints, which supports and generates AUTOSAR IFX routines.

For more information, see Code Replacement for AUTOSAR.

## Control use of signed shifts in generated code

You can now control the use of signed right shifts in your generated code. Some coding standards do not allow bitwise operations on signed integers. Disabling the use of signed shifts in generated code increases the likelihood of compliance with MISRA. When you specify that signed right shifts should not be used in your generated code, the software replaces signed shifts with a call to a function that performs the operation without the use of signed shifts.

To specify that the code generator not use signed right shifts, in the Configuration Parameters dialog box, on the **Code Generation > Code Style** pane, clear Allow right shifts on signed integers or set the parameter `EnableSignedRightShifts` to `off`.

## Code generation report with operator traceability

In R2015b, the HTML code generation report provides traceability between operators in the generated code and Simulink blocks. In the HTML report window, click an operator hyperlink to highlight the source block in the model. In the model, right-click an operator block. From the context menu, select **C/C++ Code > Navigate to C/C++ Code**. This selection highlights the generated code for the block in the HTML code generation report. Operator traceability information is included in the **Traceability Report** section of the code generation report. This information is also in the generated traceability matrix.

The code generation report does not provide traceability between operators and Stateflow or MATLAB Function blocks.

# Deployment

## Hardware Implementation Selection: Quickly generate code for popular embedded processors

Specification of hardware configurations has been simplified. Top-level Configuration Parameters dialog box panes, **Run on Target Hardware** and **Coder Target**, have been removed. Parameters previously available on those panes now appear on the **Hardware Implementation** pane. A parameter has also moved from the **Code Generation** pane to the **Hardware Implementation** pane.

This list summarizes the R2015b changes and new behavior:

- By default, the **Hardware Implementation** pane lists **Hardware board**, **Device vendor**, and **Device type** parameter fields only.
- If you use Simulink without a Simulink Coder license, initially parameters on the **Hardware Implementation** pane are disabled. To enable them, click **Enable hardware specification**. The parameters remain enabled for the current MATLAB session.
- By default, the **Hardware board** list includes: None or Determine by Code Generation system target file, and Get Hardware Support Packages. After installing a hardware support package, the list also includes corresponding hardware board names.
- If you select a hardware board name, parameters for that board appear in the dialog box display.
- Lists for the **Device vendor** and **Device type** parameters have been updated to reflect hardware that is available on the market. The default **Device vendor** and **Device type** are Intel and x86-64 (Windows64), respectively.
- If Simulink Coder is installed, the revised **Hardware Implementation** pane identifies the system target file that you selected on the **Code Generation** pane.
- A **Device details** option provides a way to display parameters for setting details such as number of bits and byte ordering.
- To specify target hardware for a Simulink support package, select a value from **Configuration Parameters > Hardware Implementation > Hardware board**. Before R2015b, you selected **Tools > Run on Target Hardware > Prepare to run**. Then, you selected a value from **Configuration Parameters > Run on Target Hardware > Target hardware**.

- To specify target hardware for an Embedded Coder support package, select a value from **Configuration Parameters > Hardware Implementation > Hardware board**. Before R2015b, you selected a value from **Configuration Parameters > Code Generation > Target hardware**.
- The **Test hardware** section was removed. Configure test hardware from the Configuration Parameters list view. Set **ProdEqTarget** to **off**, which enables parameters for configuring test hardware details.
- If you set **Configuration Parameters > Code Generation > System target file** to **ert.tlc**, **realtime.tlc**, or **autosar.tlc**, the default setting for **Configuration Parameters > Hardware Implementation > Hardware board** is **None**. If you set **System target file** to value other than **ert.tlc**, **autosar.tlc**, or **realtime.tlc**, the default setting for **Hardware board** is **Determine by Code Generation system target file**.

For more information, see Hardware Implementation Pane.

## Compatibility Considerations

Starting in R2015b:

- By default, the **Hardware Implementation** pane lists **Hardware board**, **Device vendor**, and **Device type** parameter fields only. To view parameters for setting details, such as number of bits and byte ordering, click **Device details**.
- The following devices appear on the **Hardware Implementation** pane only for models that you create with a version of the software earlier than R2015b. These devices are considered legacy devices.
  - Generic, 32-bit Embedded Processor
  - Generic, 64-bit Embedded Processor (LP64)
  - Generic, 64-bit Embedded Processor (LLP64)
  - Generic, 16-bit Embedded Processor
  - Generic, 8-bit Embedded Processor
  - Generic, 32-bit Real-Time Simulator
  - Generic, 32-bit x86 compatible
  - Intel, 8051 Compatible
  - Intel, x86–64
  - SGI, UltraSPARC Iii

In R2015b, if you open a model configured for a legacy device and change the **Device type** setting, you cannot select the legacy device again.

- Device parameter **Signed integer division rounds to** is set to **Zero** instead of **Undefined**. For some cases, numerical differences can occur in results produced with **Zero** versus **Undefined** for simulation and code generation.

This change does not apply to legacy devices.

- To associate a new model with an existing configuration set that has the following characteristics, configure the model to use the same hardware device as the existing model.
  - The model consists of a model reference hierarchy. Models in the hierarchy use different configuration sets.
  - The existing configuration set was saved as a script and associated with a configuration set variable.

If the code generator detects differences in device parameter settings, a consistency error occurs. To correct the condition, look for differences in the device parameter settings, and make the appropriate adjustments.

## Code Replacement Tool uses simplified specification

As of R2015b, where possible, the Code Replacement Tool creates code replacement table entries by using an approach that significantly reduces the amount of relevant code. Instead of using separate function calls to create the entry, conceptual arguments, and implementation arguments, the tool uses the `createCRLEntry` function to create entries from conceptual and implementation argument string specifications. The tool continues to use the more verbose approach for entries that involve:

- C++ implementations
- Data alignment
- Operator replacement with net slope arguments
- Entry parameter specifications (for example, priority, algorithm, build information)
- Semaphore and mutex function replacements

For more information, see `createCRLEntry` and Define Code Replacement Mappings.

## Code replacement support for new lookup table breakpoint specification

In R2015b, n-D Lookup Table and Prelookup blocks support a new specification for evenly spaced breakpoints. Rather than specifying breakpoints as a vector, for n-D

Lookup Table blocks, you can enter values for **First point** and **Spacing** parameters for each dimension of the breakpoint data. For Prelookup blocks, you can enter values for **First point**, **Spacing**, and **Number of points**. The code replacement software supports this new breakpoint specification through alternative conceptual function signatures for n-D Lookup Table and Prelookup blocks.

For more information, see n-D Lookup Table, Prelookup, and Lookup Table Function Code Replacement.

### **Support for Analog Devices VisualDSP++ will be removed**

Support for Analog Devices<sup>®</sup> VisualDSP++<sup>®</sup> will be removed in a future release.



## Performance

### **RAM/ROM Optimization Improvements: Generate more efficient code using reusable storage class and converting data copies to pointer assignments**

#### **Reuse input and output of a block or subsystem**

Previously, if a pair of model block I/O signals shared the same `Reusable` storage class specification, the code generator reused the root I/O signals in the generated code. In R2015b, this optimization extends to the input and output signals at a block or subsystem boundary if the input and output arguments have the same data types and sampling rates. This optimization can reduce the number of global variables, data copies, and RAM/ROM consumption in the generated code. For more information, see [Buffer Reuse Around a Block or Subsystem Boundary](#)

#### **More efficient code for large data sets**

Previously, for many data transfers involving vector signals, the code generator replaced a `for` loop controlled array element assignment with a `memcpy` function call. In R2015b, the code generator can replace a `for` loop controlled array element assignment that is inside of an `if-else` statement with a `memcpy` function call. The code generator can replace multiple array element assignments inside of a `for` loop with `memcpy` function calls. These optimizations improve execution speed.

In R2015b, the code generator attempts to replace `for` loop controlled array element assignments and `memcpy` function calls with pointer assignments. Because this optimization eliminates full array data copies, it improves execution speed and saves stack space.

Consider the following model named `dynamicLookup`. The Data Store Read blocks are copying data from their named data stores (`Data1` or `Data2`) to the input buffers of the Lookup Table.

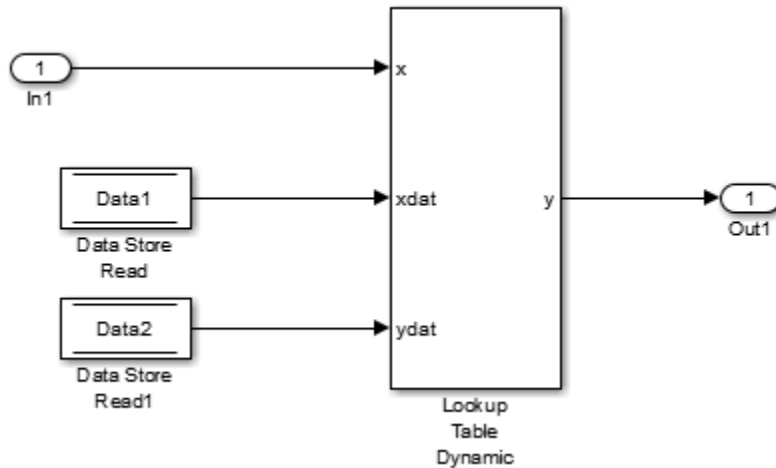

In R2015a, the code generator produced this code:

```

/* Model step function */
void dynamicLookup_step(void)
{
  /* local block i/o variables */
  real32_T rtb_DataStoreRead[10];
  uint16_T rtb_DataStoreRead1[10];
  int32_T i;

  /* DataStoreRead: '<>/Data Store Read' */
  for (i = 0; i < 10; i++) {
    rtb_DataStoreRead[i] = Data1[i];

    /* DataStoreRead: '<>/Data Store Read1' */
    rtb_DataStoreRead1[i] = Data2[i];
  }
  ...
  LookUp_real_TU16_real32_T( &(dynamicLookup_Y.Out1), &rtb_DataStoreRead1[0],
    dynamicLookup_U.In1, &rtb_DataStoreRead[0], 9U);
}

```

In R2015b, the code generator produces this code:

```

/* Model step function */
void dynamicLookup_step(void)
{
  real32_T *rtb_DataStoreRead_0;
  uint16_T *rtb_DataStoreRead1_0;
  /* DataStoreRead: '<Root>/Data Store Read' */
  rtb_DataStoreRead_0 = (&(Data1[0]));
  /* DataStoreRead: '<Root>/Data Store Read1' incorporates:
  * DataStoreRead: '<Root>/Data Store Read'
  */
  rtb_DataStoreRead1_0=(&(Data2[0]));
  ...
  LookUp_real_TU16_real32_T( &(dynamicLookup_Y.Out1), rtb_DataStoreRead1_0,
  dynamicLookup_U.In1, rtb_DataStoreRead_0, 9U);
}

```

In R2015a, the generated code contains a `for` loop and data copies to the arrays `rtb_DataStoreRead` and `rtb_DataStoreRead1`. In R2015b, the code generator replaces the `for` loop with pointer assignments to the variables `rtb_DataStoreRead_0` and `rtb_DataStoreRead1_0`. For more information, see [Optimize Memory Usage for Vector Signal Assignments](#)

## Live Execution Profiling: View PIL profile results during run-time

During a processor-in-the-loop (PIL) simulation, you can use the Simulation Data Inspector to view streamed task execution times. Previously, this data was available only at the end of the PIL simulation. For more information, see [View and Compare Code Execution Times](#).

## Enhanced support for buffer reuse at the root-level input and output ports

### Reusable custom storage class for model block input and output ports

Previously, if a pair of root-level model input and output signals used the same `Reusable` storage class specification, the code generator reused the root I/O signals in the generated code. In R2015b, the code generator enables this optimization for models containing subsystems. This optimization can reduce data copies, global variables, and ROM/RAM consumption. For example, consider the following model named `IObuffreuse`.

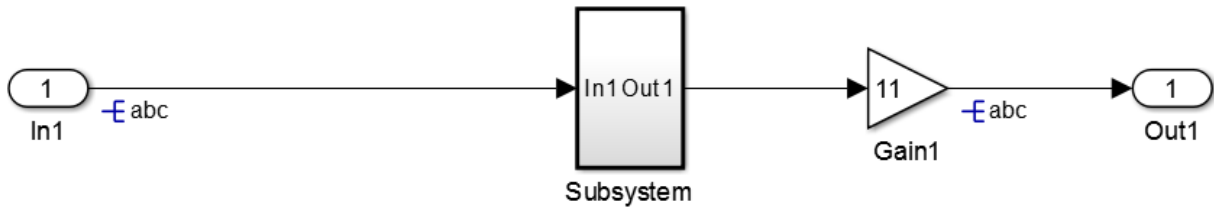

In R2015a, the code generator produces the following code:

```
void IObuffreuse_Subsystem(const real_T rtu_In1[6], B_Subsystem_IObuffreuse_T
    *localB)
{
    int32_T i;
    for (i = 0; i < 6; i++) {
        localB->ca[i] = 4.0 * rtu_In1[i];
    }
}

void IObuffreuse_step(void)
{
    int32_T i;
    for (i = 0; i < 6; i++) {
        abc_0[i] = abc[i];
    }

    IObuffreuse_Subsystem(abc_0, &IObuffreuse_B.Subsystem);
    for (i = 0; i < 6; i++) {
        abc[i] = 11.0 * IObuffreuse_B.Subsystem.ca[i];
    }
}
```

In R2015b, the code generator produces the following code:

```
void IObuffreuse_Subsystem(const real_T rtu_In1[6], B_Subsystem_IObuffreuse_T
    *localB)
{
    int32_T i;
    for (i = 0; i < 6; i++) {
        localB->ca[i] = 4.0 * rtu_In1[i];
    }
}

void IObuffreuse_step(void)
```

```

{
  int32_T i;
  IObuffreuse_Subsystem((&(abc[0])), &IObuffreuse_B.Subsystem);
  for (i = 0; i < 6; i++) {
    abc[i] = 11.0 * IObuffreuse_B.Subsystem.ca[i];
  }
}

```

In R2015a, the generated code contains an additional buffer named `abc_0`. The code also contains a full array data copy from `abc_0` to `abc` in the model step function. In R2015b, the additional buffer and the full array data copy are not in the generated code.

For more information on how to configure your model to use this optimization, see [Buffer Reuse for Model Block Boundary and Unit Delay](#).

### Combined input and output arguments with function prototype control

Previously, the code generator tried to reuse buffers for a pair of model step function input and output ports that were assigned the same argument name using function prototype control. This optimization can reduce data copies, global variables, and ROM/RAM consumption. In R2015b, the code generator enables this optimization for models containing subsystems. For example, consider the following model named `FPCioreuse`.

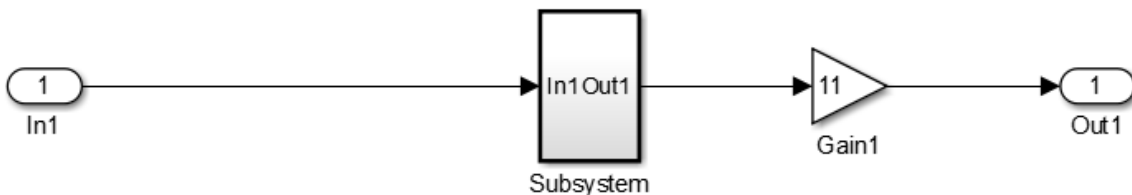

In R2015a, the code generator produces the following code:

```

void mg956114fpc2_custom(real_T arg_Inout1[6])
{
  int32_T i;
  for (i = 0; i < 6; i++) {
    arg_Inout1_0[i] = arg_Inout1[i];
  }
}

```

```
FPCioReuse_Subsystem(arg_Inout1_0, &FPCioReuse_B.Subsystem);  
for (i = 0; i < 6; i++) {  
    arg_Inout1[i] = 11.0 * FPCioReuse_B.Subsystem.ca[i];  
}  
}
```

In R2015b, the code generator produces the following code:

```
void mg956114fpc2_custom(real_T arg_Inout1[6])  
{  
    int32_T i;  
    FPCioReuse_Subsystem(arg_Inout1, &FPCioReuse_B.Subsystem);  
    for (i = 0; i < 6; i++) {  
        arg_Inout1[i] = 11.0 * FPCioReuse_B.Subsystem.ca[i];  
    }  
}
```

In R2015a, the code contains an additional buffer named `arg_Inout1_0`. The code also contains a full array data copy from `arg_Inout1` to `arg_Inout1_0`. In R2015b, the temporary buffer and full array data copy are not in the generated code.

To configure model step function I/O arguments to allow buffer reuse, use either C function prototype control or C++ class interface control. For more information, see [Combine Input and Output Arguments in Model Step Interface](#).

## More efficient code for small subsystems

Previously, if a subsystem was in a model or model hierarchy more than once and the subsystem **function packaging** was set to `auto`, Embedded Coder generated a separate, reusable function with arguments.

In R2015b, if these subsystems are small and not too complex, the code generator inlines the code for each subsystem. This enhancement reduces data copies, RAM consumption, and code size. It also improves execution speed. For large-scale models containing thousands of subsystems, this enhancement saves time because you do not have to manually set **function packaging** to `inline` for each subsystem.

Consider the following model named `auto_funcpackaging`. This model contains two identical, simple subsystems named `If Action Subsystem` and `If Action Subsystem1`.

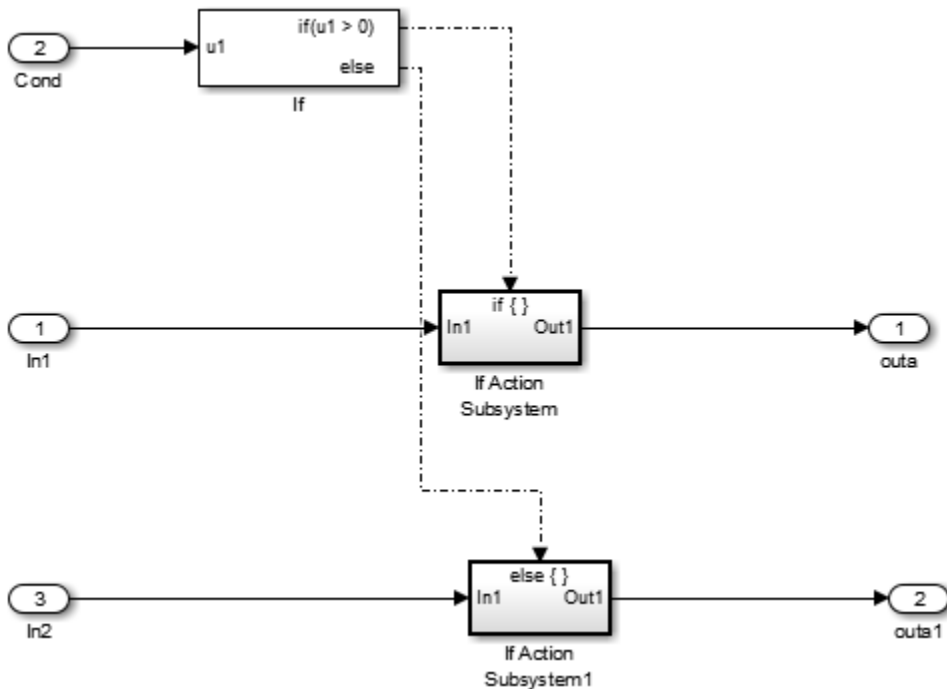

In R2015a, the code generator produced the following code:

```
void auto_funcpack_IfActionSubsystem(real_T rtu_In1,
    rtDW_IfActionSubsystem_auto_fun *localDW)
{
    localDW->Gain = 4.0 * rtu_In1;
}

void auto_funcpackaging_step(void)
{
    if (auto_funcpackaging_U.Cond > 0.0) {
        auto_funcpack_IfActionSubsystem(auto_funcpackaging_U.In1,
            &auto_funcpackagin_DWork.IfActionSubsystem);
    } else {
        auto_funcpack_IfActionSubsystem(auto_funcpackaging_U.In2,
            &auto_funcpackaging_DWork.IfActionSubsystem);
    }

    auto_funcpackaging_Y.outa =
```

```
    auto_funcpackaging_DWork.IfActionSubsystem.Gain;  
    auto_funcpackaging_Y.outa1 =  
        auto_funcpackaging_DWork.IfActionSubsystem1.Gain;  
}
```

In R2015b, the code generator produces this code:

```
void auto_funcpackaging_step(void)  
{  
    if (auto_funcpackaging_U.Cond > 0.0) {  
        auto_funcpackaging_Y.outa = 4.0 * auto_funcpackaging_U.In1;  
    } else {  
        auto_funcpackaging_Y.outa1 = 4.0 * auto_funcpackaging_U.In2;  
    }  
}
```

In R2015a, the code generator produced the reusable function named `auto_funcpack_IfActionSubsystem`, which is called twice in the generated code. In R2015b, because the subsystem consists of simple signal paths, the code generator inlines the code for each subsystem. For more information, see [Generate Inlined Subsystem Code](#)

## More efficient code for Simulink.Bus objects

Previously, if a Data Store Memory block stored a `Simulink.Bus` object, and Data Store Read and Data Store Write blocks updated the `Simulink.Bus` object, there were extra data copies in the generated code.

In R2015b, the code generator has improved expression folding capabilities, so that these additional data copies are not in the generated code. This enhancement reduces code size and RAM consumption and increases execution speed.

For example, consider the following subsystem.



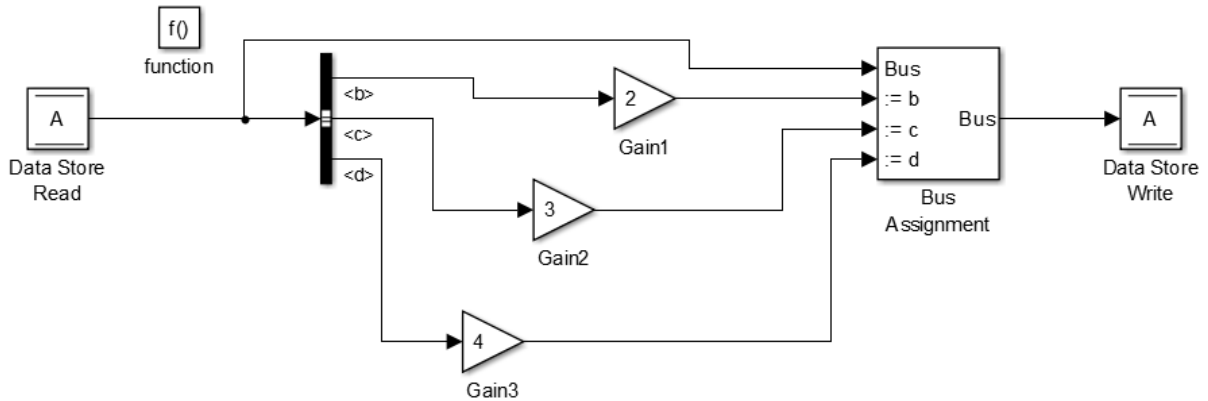

In R2015a, the code generator produced this code:

```
void f(void)
{
    real_T rtb_Gain2[170];
    real_T rtb_Gain3[190];
    int32_T i;
    for (i = 0; i < 170; i++) {
        rtb_Gain2[i] = 3.0 * rtDW.A.c[i];
    }

    for (i = 0; i < 190; i++) {
        rtb_Gain3[i] = 4.0 * rtDW.A.d[i];
    }

    for (i = 0; i < 150; i++) {
        rtDW.A.b[i] *= 2.0;
    }

    for (i = 0; i < 170; i++) {
        rtDW.A.c[i] = rtb_Gain2[i];
    }

    for (i = 0; i < 190; i++) {
        rtDW.A.d[i] = rtb_Gain3[i];
    }
}
```

In R2015b, the code generator produces this code:

```
void f(void)
{
    int32_T i;
    for (i = 0; i < 150; i++) {
        rtDW.A.b[i] *= 2.0;
    }

    for (i = 0; i < 170; i++) {
        rtDW.A.c[i] *= 3.0;
    }

    for (i = 0; i < 190; i++) {
        rtDW.A.d[i] *= 4.0;
    }
}
```

In R2015a, the generated code contained full array data copies from `rtb_Gain2` to `rtDW.A.c` and from `rtb_Gain3` to `rtDW.A.d`. In R2015b, if a Bus Assignment block source and destination are the same Data Store Memory block, the code generator implements the Bus Assignment block in place in the generated code. As a result, the extra data copies are not in the generated code.

## Enhanced local variable reuse

In R2015b, the code generator reuses more local variables, which reduces RAM and ROM consumption.

Consider the following model named `local_reuse`. This model contains four identical MATLAB Functions and a subsystem. The signals are matrices of size `[5 5]`.

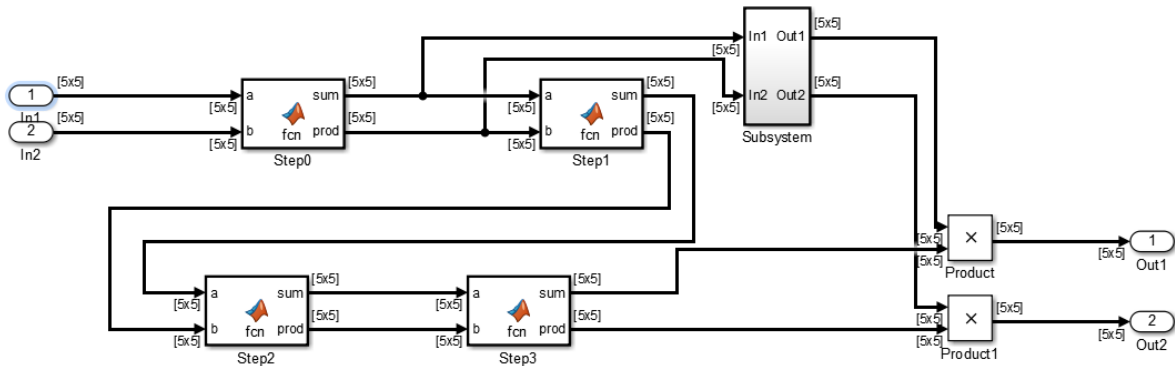

In R2015a, for the model step function, the code generator produced this code:

```
void local_reuse_step(void)
{
    real_T rtb_sum_g[25];
    real_T rtb_prod_o[25];
    real_T rtb_sum_a[25];
    real_T rtb_prod_h[25];
    real_T rtb_sum_j0[25];
    real_T rtb_prod_i[25];
    int32_T i;
    local_reuse_Step0(local_reuse_U.In1, local_reuse_U.In2, rtb_sum_g, rtb_prod_o);
    local_reuse_Subsystem(rtb_sum_g, rtb_prod_o, local_reuse_B.Gain,
        local_reuse_B.Gain1, &local_reuse_DW.Subsystem);
    local_reuse_Step0(rtb_sum_g, rtb_prod_o, rtb_sum_a, rtb_prod_h);
    local_reuse_Step0(rtb_sum_a, rtb_prod_h, rtb_sum_j0, rtb_prod_i);
    local_reuse_Step0(rtb_sum_j0, rtb_prod_i, rtb_sum_g, rtb_prod_o);
    for (i = 0; i < 25; i++) {
        local_reuse_Y.Out1[i] = local_reuse_B.Gain[i] * rtb_sum_g[i];
        local_reuse_Y.Out2[i] = local_reuse_B.Gain1[i] * rtb_prod_o[i];
    }
}
```

The generated code contained six local arrays, `rtb_sum_g`, `rtb_prod_o`, `rtb_sum_a`, `rtb_prod_h`, `rtb_sum_j0`, and `rtb_prod_i` to handle the input and output of the four MATLAB Functions.

In R2015b, for the model step function, the code generator produces this code:

```
void local_reuse_step(void)
```

```
{
  real_T rtb_sum_g[25];
  real_T rtb_prod_o[25];
  real_T rtb_sum_a[25];
  real_T rtb_prod_h[25];
  int32_T i;
  local_reuse_Step0(local_reuse_U.In1, local_reuse_U.In2, rtb_sum_g, rtb_prod_o);
  local_reuse_Subsystem(rtb_sum_g, rtb_prod_o, local_reuse_B.Gain,
                       local_reuse_B.Gain1, &local_reuse_DW.Subsystem);
  local_reuse_Step0(rtb_sum_g, rtb_prod_o, rtb_sum_a, rtb_prod_h);
  local_reuse_Step0(rtb_sum_a, rtb_prod_h, rtb_sum_g, rtb_prod_o);
  local_reuse_Step0(rtb_sum_g, rtb_prod_o, rtb_sum_a, rtb_prod_h);
  for (i = 0; i < 25; i++) {
    local_reuse_Y.Out1[i] = local_reuse_B.Gain[i] * rtb_sum_a[i];
    local_reuse_Y.Out2[i] = local_reuse_B.Gain1[i] * rtb_prod_h[i];
  }
}
```

The generated code contains four local arrays, `rtb_sum_g`, `rtb_prod_o`, `rtb_sum_a`, and `rtb_prod_h` to handle the input and output of the four MATLAB Functions. Because the code generator reuses more local variables, there are two less local arrays than there were in R2015a.

## Enhanced consolidation of for loops

Previously, the code generator tried to combine `for` loops that had the same number of iterations. In R2015b, the code generator combines more cases of `for` loops that have the same number of iterations. These `for` loops read and write to separate sections of the same array and write to scalar variables. This optimization conserves ROM consumption and improves execution speed.

Consider the following model named `loopfusion`. This model contains two Mux blocks that combine vector signals from three Inport blocks into an output vector signal. The three input vector signals have a dimension size of 5. The output vector signal has a dimension size of 15.

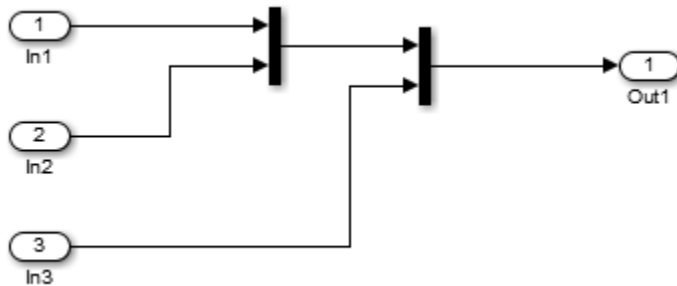

In R2015a, the code generator produced this code:

```

/* Model step function */
void loopfusion_step(void)
{
    int32_T i;

    /* Output: '<Root>/Out1' incorporates:
     * Inport: '<Root>/In1'
     * Inport: '<Root>/In2'
     * Inport: '<Root>/In3'
     */
    for (i = 0; i < 5; i++) {
        loopfusion_Y.Out1[i] = loopfusion_U.In1[i];
    }

    for (i = 0; i < 5; i++) {
        loopfusion_Y.Out1[i + 5] = loopfusion_U.In2[i];
    }

    for (i = 0; i < 5; i++) {
        loopfusion_Y.Out1[i + 10] = loopfusion_U.In3[i];
    }

    /* End of Output: '<Root>/Out1' */
}

```

In R2015a, there were three for loops that wrote to three separate sections of the array, `loopfusion_Y.Out1`.

In R2015b, the code generator produces this code:

```

/* Model step function */

```

```
void loopfusion_step(void)
{
    int32_T i;

    /* Outputport: '<Root>/Out1' incorporates:
     * Inport: '<Root>/In1'
     * Inport: '<Root>/In2'
     * Inport: '<Root>/In3'
     */
    for (i = 0; i < 5; i++) {
        loopfusion_Y.Out1[i] = loopfusion_U.In1[i];
        loopfusion_Y.Out1[i + 5] = loopfusion_U.In2[i];
        loopfusion_Y.Out1[i + 10] = loopfusion_U.In3[i];
    }

    /* End of Outputport: '<Root>/Out1' */
}
```

In R2015b, there is one `for` loop that writes to three separate sections of the array, `loopfusion.Out1`.

## Verification

### Faster SIL and PIL Verification Workflow

R2015b enables faster software-in-the-loop (SIL) and processor-in-the-loop (PIL) verification by providing:

- Model block SIL/PIL and SIL/PIL block support for fast restart — You can tune parameters and run simulations without model recompilation.
- Model block SIL/PIL support for Accelerator mode — If you have a model with Model blocks in SIL/PIL mode, you can run the top-model simulation in Accelerator mode, which speeds up the simulation of components that are not in SIL or PIL mode.

For more information, see [Speed Up SIL/PIL Verification](#) .

### Code generation assumptions verified during PIL simulation

The settings on the **Configuration Parameters > Hardware Implementation** pane specify target behavior, which result in the implementation of implicit assumptions in the generated code. Incorrect settings can lead to:

- Suboptimal code
- Code execution failure, incorrect code output, and nondeterministic code behavior

At the start of a PIL simulation, the software verifies the **Hardware Implementation** pane settings with reference to the target hardware. The software checks:

- The correctness of settings. For example, the integer bit length in the **Number of bits: int** field.
- Whether the settings are optimized. For example, the rounding of signed integer division in the **Signed integer division rounds to** field.

If required, the software generates warnings and errors.

### SIL and PIL support for C++ class root-level I/O access methods

The **Configuration Parameters > Code Generation > Interface > External I/O access** parameter (`GenerateExternalIOAccessMethods`) specifies whether to

generate root-level I/O signal access methods for a C++ class. R2015b provides SIL and PIL simulation support for these parameter values:

- **Structure-based method** — Code generator produces noninlined, structure-based access methods.
- **Inlined structure-based method** — Code generator produces inlined, structure-based access methods.

Previously, SIL and PIL simulations supported only access methods that were not structure-based.

For more information, see [External I/O access and Configure Step Method for Model Class](#).

## Removal of **Generate code only** parameter restriction

You can run top-model and Model block SIL and PIL simulations even if you select the **Generate code only** (`GenCodeOnly`) parameter. Previously, running the SIL and PIL simulations with the parameter produced an error. For a SIL or PIL block, the restriction still applies. For additional **Generate code only** enhancements, see [Smarter Code Regeneration: Regenerate code only when model settings that impact code are modified](#).

## Removal of scheduling limitations that caused algebraic loops

In R2015b, the internal scheduling of messages between host and target in a SIL or PIL simulation is modified. This modification removes the S-function scheduling limitations that previously caused algebraic loops in SIL and PIL simulations.



## Check bug reports for issues and fixes

Software is inherently complex and is not free of errors. The output of a code generator might contain bugs, some of which are not detected by a compiler. MathWorks reports critical known bugs brought to its attention on its Bug Report system at [www.mathworks.com/support/bugreports/](http://www.mathworks.com/support/bugreports/). Use the Saved Searches and Watched Bugs tool with the search phrase "Incorrect Code Generation" to obtain a report of known bugs that produce code that might compile and execute, but still produce wrong answers.

The bug reports are an integral part of the documentation for each release. Examine periodically all bug reports for a release, as such reports may identify inconsistencies between the actual behavior of a release you are using and the behavior described in this documentation.

In addition to reviewing bug reports, you should implement a verification and validation strategy to identify potential bugs in your design, code, and tools.



# R2015a

Version: 6.8

New Features

Compatibility Considerations

## Code Generation from MATLAB Code

### Indent style and size control for generated C/C++ code

You can control the indent style and size in C/C++ code generated from MATLAB code.

You can specify the K&R indent style or the Allman indent style. The K&R style places the opening brace of a control statement on the same line as the control statement. The Allman style places the opening brace on its own line at the same indentation level as the control statement.

Indent size is the number of characters per indentation level.

To specify the indent style and size using the MATLAB Coder app:

- 1 On the **Generate Code** page, to open the **Generate** dialog box, click the **Generate** arrow .
- 2 Set **Build type** to one of the following:
  - Source Code
  - Static Library (.lib)
  - Dynamic Library (.dll)
  - Executable (.exe)
- 3 Click **More Settings**.
- 4 On the **All Settings** tab, under **Advanced**, set **Indent style** to K&R or Allman.
- 5 On the **All Settings** tab, under **Advanced**, set **Indent size** to an integer from 2 to 8.

To specify the indent style and size using the command-line interface:

- 1 Create a code configuration object for 'lib', 'dll', or 'exe'. For example:

```
cfg = coder.config('lib','ecoder',true); % or dll or exe
```
- 2 Set the `IndentStyle` property to 'K&R' or 'Allman'. For example:

```
cfg.IndentStyle = 'Allman';
```
- 3 Set the `IndentSize` property to an integer from 2 to 8. For example:

```
cfg.IndentSize = 4;
```

See Specify Indent Style for C/C++ Code.

## Improved MISRA-C compliance for bitwise operations on signed integers

In previous releases, MATLAB Coder replaced multiplication by powers of two with signed left bitwise shifts. In R2015a, to increase the likelihood of compliance with MISRA C, you can disable this replacement. MISRA<sup>®</sup> rule 12.7 does not allow bitwise operations on signed integers.

To specify that MATLAB Coder not replace multiplication by powers of two with signed left bitwise shifts:

- Using the MATLAB Coder app:

- 1** On the **Generate Code** page, to open the **Generate** dialog box, click the **Generate** arrow .

- 2** Set **Build type** to one of the following:

- Source Code
- Static Library (.lib)
- Dynamic Library (.dll)
- Executable (.exe)

- 3** Click **More Settings**.

- 4** On the **Code Appearance** tab, clear the **Use signed shift left for fixed-point operations and multiplication by powers of 2** check box.

- Using the command-line interface:

- 1** Create a code configuration object for 'lib', 'dll', or 'exe'. For example:

```
cfg = coder.config('lib','ecoder',true); % or dll or exe
```

- 2** Set the `EnableSignedLeftShifts` property to `false`. For example:

```
cfg.EnableSignedLeftShifts = false;
```

See Control Signed Left Shifts in Generated Code.

## Improved MISRA-C type cast compliance

You can specify the casting mode that MATLAB Coder uses for data type casts in the generated C/C++ code. You can specify these modes:

Casting Mode	Description
Nominal	Nominal casting mode is the default casting mode. The generated C/C++ code uses the default C compiler data type casting. When you do not have special data type information requirements, choose this option.
Standards Compliant	Generated C/C++ code has data type casts that conform to MISRA standards. The MISRA data type casting mode eliminates common MISRA standard violations, including address arithmetic and assignment. It reduces 10.1, 10.2, 10.3, and 10.4 violations.
Explicit	Generated C/C++ code has explicit data type casts. Explicit data type casts provide information about the amount of memory that the variable uses and the level of precision for calculations using the variable.

To specify the casting mode using the MATLAB Coder app:

- 1 On the **Generate Code** page, to open the **Generate** dialog box, click the **Generate** arrow .
- 2 Click **More Settings**.
- 3 On the **All Settings** tab, under **Advanced**, set **Casting mode** to **Nominal**, **Standards Compliant**, or **Explicit**.

To specify the casting mode using the command-line interface:

- 1 Create a code configuration object for 'lib', 'dll', or 'exe'. For example:
 

```
cfg = coder.config('lib', 'ecoder', true); % or dll or exe
```

- 2 Set the `CastingMode` property to `'Nominal'`, `'Standards'`, or `'Explicit'`. For example:

```
cfg = CastingMode = 'Standard';
```

See Control Data Type Casts in Generated Code.

## Model Architecture and Design

### **AUTOSAR improvements including multi-runnable modeling and code efficiency**

R2015a provides many enhancements to Simulink modeling of AUTOSAR elements and AUTOSAR code generation. Highlights include:

- AUTOSAR multi-runnable modeling using Simulink rate-based multitasking
- Improved traceability for AUTOSAR RTE implicit read

For more information about AUTOSAR-related enhancements in R2015a, see:

- Under Model Architecture and Design:
  - “AUTOSAR multi-runnable modeling using Simulink rate-based multitasking” on page 6-7
  - “Enhanced modeling with AUTOSAR system constants” on page 6-8
  - “AUTOSAR CompuMethod enhancements” on page 6-8
- Under Code Generation:
  - “Improved traceability for AUTOSAR RTE implicit read” on page 6-15
  - “Configurable aliveTimeout value for AUTOSAR ports” on page 6-16
  - “AUTOSAR calibration parameter export for COM\_AXIS lookup tables” on page 6-16

### **Combined input/output arguments with function prototype control**

In R2015a, the code generator tries to reuse buffers for a pair of model step function input/output ports assigned the same argument name using function prototype control. The corresponding inport and outport blocks must have the same data type and sampling rate. This reuse can eliminate buffers in the generated code.

To configure model step function I/O arguments to allow buffer reuse, use either C function prototype control or C++ class interface control. For more information, see [Combine Input and Output Arguments in Model Step Interface](#).



## Improved MISRA-C compliance for bitwise operations on signed integers

You can specify that the code generator not replace multiplications by powers of two with signed bitwise shifts, increasing the likelihood of generating code that is compliant with MISRA-C. MISRA rule 12.7 does not allow bitwise operations on signed integers. Previously, the code generator replaced multiplications by powers of two with signed bitwise shifts.

To specify that the code generator not replace multiplications by power of two with signed bitwise shifts, in the Configuration Parameters dialog box, on the **Code Generation > Code Style** pane, clear Replace multiplications by powers of two with signed bitwise shifts or set the parameter `EnableSignedLeftShifts` to `off`.

To improve MISRA-C compliance for bitwise operations on signed integers, run the following checks:

- Check for bitwise operations on signed integers - New check to identify blocks that contain bitwise operations on signed integers.
- Check configuration parameters for MISRA-C:2004 compliance - Enhanced check that verifies that you cleared **Code Generation > Code Style > Replace multiplications by powers of two with signed bitwise shifts**.

## AUTOSAR multi-runnable modeling using Simulink rate-based multitasking

In previous releases, you modeled a multi-runnable AUTOSAR software component using Simulink function-call subsystems or Simulink Function blocks at the top level of a model. In R2015a, you can model a multi-runnable AUTOSAR software component using Simulink rate-based multitasking. Using this approach, you can:

- Create an AUTOSAR software component with multiple periodic runnables in Simulink.
- Import an AUTOSAR software component with multiple periodic runnables from `arxml` into Simulink.
- Migrate an existing rate-based, multitasking Simulink model to the AUTOSAR target.

For more information, see [Multi-Runnable Software Components and Configure Multiple Runnables Using Rate-Based Multitasking](#).

## Compatibility Considerations

Before R2015a, you could not configure a multitasking model for the AUTOSAR target. If you attempted to import an AUTOSAR software component with multiple periodic runnables and create a rate-based model (that is, if you invoked `arxml.importer` method `createComponentAsModel` with `CreateInternalBehavior` set to `false`), the importer would:

- Discard all but one runnable and create a rate-based, single-tasking model.
- For each AUTOSAR port, create an inport or outport and related Simulink elements even if the port was not accessed by the AUTOSAR runnable.

Performing the same import in R2015b produces different results in two respects. The importer:

- Creates a rate-based, multitasking model, rather than rate-based, single-tasking.
- For each AUTOSAR port, creates an inport or outport and related Simulink elements only if the port is accessed by an AUTOSAR runnable.

## Enhanced modeling with AUTOSAR system constants

In previous releases, you could define AUTOSAR system constants (`SwSystemConstants`) in Simulink, but their use was limited to condition formulas inside variant subsystems and model references. In R2015a, you can directly reference AUTOSAR system constants in Simulink algorithms. For example, you could reference a system constant in a Gain block.

For more information, see [System Constants and Model AUTOSAR Component Behavior](#).

## AUTOSAR CompuMethod enhancements

R2015a significantly enhances AUTOSAR CompuMethod related workflows in Simulink. You can:

- Configure the properties of imported AUTOSAR CompuMethods
- Create and configure AUTOSAR CompuMethods in Simulink
- Use externally-defined AUTOSAR CompuMethods
- Use externally-defined AUTOSAR Units

For more information, see [Configure AUTOSAR CompuMethods](#).

## **Preprocessor conditionals for single variant choice**

Previously, you could not generate preprocessor conditionals if a variant subsystem in your model contained a single variant choice.

In R2015a, you can represent an empty subsystem as a variant choice. During code generation, if the empty variant choice is inactive, the generated code does not contain the `#elif` preprocessor conditional. Instead, the active variant choice is enclosed between a `#if` and an `#endif`.

## Data, Function, and File Definition

### Control of Boolean and data type limit identifiers in generated code

In R2015a, if you want to associate the data type limit identifiers with the data type names, you can use command-line parameters to replace these default data type limit identifiers:

- `MAX_int8_T`
- `MAX_int16_T`
- `MAX_int32_T`
- `MAX_uint8_T`
- `MAX_uint16_T`
- `MAX_uint32_T`
- `MIN_int8_T`
- `MIN_int16_T`
- `MIN_int32_T`

You can also use command-line parameters to:

- Replace the default `true` and `false` Boolean identifiers.
- Import a header file with the Boolean and data type limit identifier definitions.

For more information, see [Specify Boolean and Data Type Limit Identifiers](#).

### Names of built-in storage classes reserved

You can no longer define custom storage classes with the same name as the built-in storage classes `Auto`, `SimulinkGlobal`, `ExportedGlobal`, `ImportedExtern`, and `ImportedExternPointer`. The Custom Storage Class Designer now fails validation of custom storage classes that have these names.

### Compatibility Considerations

If you previously defined custom storage classes with the same name as the built-in storage classes, MATLAB returns an error when you try to create data objects that use

any of the custom storage classes defined in the affected package. If you try to load such data objects from a MAT-file, the objects do not load successfully.

To resolve these compatibility issues:

- 1** Rename the affected custom storage classes.
- 2** Update your MATLAB code to use the new names.
- 3** Recover affected data objects from existing MAT-files.

To recover affected data objects from existing MAT-files:

- 1** Start a prior release of MATLAB that uses the affected custom storage classes.
- 2** Load the MAT-files.
- 3** Use the function `matlab.io.saveVariablesToScript` to generate a MATLAB script that defines the affected data objects.
- 4** Manually update the generated script with the new names of your custom storage classes.
- 5** In release R2015a or later of MATLAB, rename the affected custom storage classes.
- 6** Run the generated script in release R2015a or later of MATLAB.

## Code Generation

### **Simplified Code Replacement Library specification plus more replacements involving integer operations**

#### **Simplified Code Replacement Library specification**

R2015a introduces a simpler approach to defining code replacement table entries programmatically. This approach significantly reduces the amount of code that you write. Consider using this approach if both of the following conditions apply:

- The workflow that you use for defining mappings involves copying, pasting, and editing existing mappings.
- You prefer not to use the Code Replacement Tool to create an initial mapping definition.

To use the approach, specify conceptual and implementation information for a table entry as detailed string specifications in a call to the function `createCRLEntry`.

This approach for defining mappings for code replacement table entries does not support:

- C++ implementations
- Data alignment
- Operator replacement with net slope arguments
- Entry parameter specifications (for example, priority, algorithm, building information)
- Semaphore and mutex function replacements

For more information, see `createCRLEntry` and `Define Code Replacement Mappings`.

#### **More replacements involving integer operations**

As of R2015a, code replacement opportunities have been improved for the following binary-point scaling operations. To increase match opportunities, the code generator applies equivalent scaling to inputs before performing the stored integer operation. However, input scaling occurs only if a match exists and the code generator is able to apply the replacement for the stored integer operation.

Operator	Key	Scalar, Vector, Matrix Support	Real, Complex Support
Addition (+)	RTW_OP_ADD	Scalar Vector Matrix	Real Complex
Subtraction (-)	RTW_OP_MINUS	Scalar Vector Matrix	Real Complex
Multiplication (*)	RTW_OP_MUL	Scalar	Real
Division (/)	RTW_OP_DIV	Scalar	Real
Element-wise matrix multiplication (.*)	RTW_OP_ELEM_MUL	Vector Matrix	Real

## Improved readability for shared header file 'rtwtypes.h'

To improve code readability and reduce code review cost, in the `rtwtypes.h` file, the software does not generate the following definitions:

- The preprocessor directive `#define __TMWTYPES__`. The removal of this preprocessor directive prevents the inclusion of `tmwtypes.h`, making `rtwtypes.h` the single source of type definitions.
- Definitions for zero-crossing detection in triggered subsystems. For example:

```
#ifndef __ZERO_CROSSING_TYPES_H__
#define __ZERO_CROSSING_TYPES_H__

/* Trigger directions: falling, either, and rising */
typedef enum {
    FALLING_ZERO_CROSSING = -1,
    ANY_ZERO_CROSSING = 0,
    RISING_ZERO_CROSSING = 1
} ZCDirection;

/* Previous state of a trigger signal */
...
#endif
```

Models containing triggered subsystems require zero-crossing definitions when the trigger is rising, falling, or either. In R2015a, the software generates these

definitions in a separate file called `zero_crossing_types.h`. The software creates the file only if the model requires the file.

## Compatibility Considerations

Because of the removal of the `#define __TMWTYPES__` directive, the `rtwtypes.h` file generated using R2015a might not be compatible with code that you generate using a previous release. For example, in some circumstances, the generated code from an older release might include `tmwtypes.h` after `rtwtypes.h`. This code does not compile without the `#define __TMWTYPES__` directive.

If your build process uses custom code that includes the header file `tmwtypes.h` instead of `rtwtypes.h`, you might observe a compiler error that indicates a redefined type.

To avoid this error, in the custom code, replace:

```
#include "tmwtypes.h"
```

with:

```
#include "rtwtypes.h"
```

If you use the `mex` command to compile custom code for an S-function, include `tmwtypes.h` for the `mex` compilation and `rtwtypes.h` for the code generation compilation:

```
#ifdef MATLAB_MEX_FILE
#include "tmwtypes.h"
#else
#include "rtwtypes.h"
#endif
```

Alternatively, before generating code for your model, configure the model for backward compatibility by setting the parameter `InferredTypesCompatibility` to `on`.

```
set_param(model, 'InferredTypesCompatibility', 'on')
```

When you enable backward compatibility, the code generator creates the preprocessor directive `#define __TMWTYPES__` inside `model.h`.

## New and enhanced Model Advisor checks for MISRA-C compliance

To improve MISRA-C compliance, you can run the following Model Advisor checks:



Check	New or Enhanced	Description	Addresses MISRA-C Rule Numbers
Check for bitwise operations on signed integers	New	Identifies blocks that contain bitwise operations on signed integers.	12.7
Check configuration parameters for MISRA-C:2004 compliance	Enhanced	Now verifies that you cleared <b>Code Generation &gt; Code Style &gt; Replace multiplications by powers of two with signed bitwise shifts</b>	12.7
Check for blocks not recommended for MISRA-C:2004 compliance	Enhanced	Now identifies Lookup Table blocks using cubic spline interpolation or extrapolation methods.	11.4 and 11.5

## Improved traceability for AUTOSAR RTE implicit read

AUTOSAR code generation now generates more traceable and readable code for a root inport that models an AUTOSAR RTE implicit read, especially when the inport data type is a matrix.

For example, consider root inport In1 the following model:

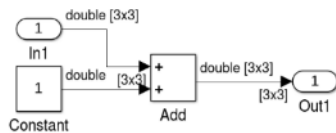

In R2014b, the generated code introduces a hidden Signal Conversion block:

```

void Runnable_Step(void)
{
  const real_T *rtb_TmpSignalConversionAtIn10ut;
  real_T tmp[9];
  int32_T
  /* SignalConversion: '<Root>/TmpSignal ConversionAtIn10output1' incorporate
  Inport: '<Root>/In1 */
  rtb_TmpSignalConversionAtIn10ut = Rte_IRead_Runnable_Step_Input_Element0();

```

```
/* Sum: '<Root>/Add' incorporates:
 * Constant: '<Root>/Constant'
 */
for (i = 0; i < 9; i++) {
    tmp[i] = rtb_TmpSignalConversionAtIn1Out [i] + 1.0;
}
...
Rte_IWrite_Runnable_Step_Output_Output(tmp);
}
```

In R2015a, the generated code is traceable and more readable. A hyperlink is generated for `<Root>/In1`.

```
void Runnable_Step(void)
{
    const real_T *tmp_In1;
    real_T tmp[9];
    int32_T i;
    /* Inport: '<Root>/In1' */
    tmp_In1 = Rte_IRead_Runnable_Step_Input_Element0();
    /* Sum: '<Root>/Add' incorporates:
     * Constant: '<Root>/Constant'
     */
    for (i = 0; i < 9; i++) {
        tmp[i] = rtb_tmp_In1[i] + 1.0;
    }
    ...
    Rte_IWrite_Runnable_Step_Output_Output(tmp);
}
```

## Configurable aliveTimeout value for AUTOSAR ports

In AUTOSAR applications, the `aliveTimeout` value for an AUTOSAR port specifies the amount of time in seconds after which the AUTOSAR software component must be notified if the port has not received data according to a specified timing description. In previous releases, `arxml` export generated a fixed `aliveTimeout` value of 60 for each AUTOSAR port, without providing a way to modify the `aliveTimeout` value in Simulink.

The software now allows you to configure an `aliveTimeout` value that subsequent `arxml` exports generate for each AUTOSAR port. For more information, see [Configure AUTOSAR Port aliveTimeout Value](#).

## AUTOSAR calibration parameter export for COM\_AXIS lookup tables

For shared axis (`COM_AXIS`) lookup tables, AUTOSAR code generation now exports `arxml` that supports run-time calibration of lookup table parameters. To configure a

lookup table for run-time calibration, add an n-D Lookup Table block to your model and configure it for COM\_AXIS data. For table data and axis data that you want to tune or manipulate at run-time, reference AUTOSAR calibration parameters. For more information, see Calibration Parameters for COM\_AXIS Lookup Tables.

## Fixed-point scaling information in Code Interface Report

Fixed-point scaling information is added to the code generation report in the **Code Interface Report** section. Better accessibility to this information makes it easier for you to integrate your code with generated code containing fixed-point data types. Each fixed-point entry in a report table has a value in the new **Scaling** column giving its data type and fraction length using Simulink fixed-point data type notation. Here is an example of fixed-point data representations in the **Outputs** table.

### Outputs

Block Name	Code Identifier	Data Type	Scaling	Dimension
<a href="#">&lt;Root&gt;/Out1</a>	<i>Defined externally</i>	uint32_T	ufix32_En14	1
<a href="#">&lt;Root&gt;/Out2</a>	<i>Defined externally</i>	int32_T	sfix32_En12	1

You must have a Fixed-Point Designer™ license to see fixed-point scaling information in the report. For more information on how scaling is represented in the table, see Fixed-Point Data Type and Scaling Notation.

## Unsigned integer minimum data limit identifiers

The following unsigned integer minimum data limit identifiers are no longer defined in `rtwtypes.h`:

- MIN\_uint8\_T
- MIN\_uint16\_T
- MIN\_uint32\_T
- MIN\_uint64\_T

Previously, the unsigned integer minimum data limit identifiers defined in `rtwtypes.h` were potentially not used in the generated code:

- Standard C header files do not provide an unsigned integer minimum data limit constant.
- In most instances, the code generator did not replace 0 with the unsigned integer minimum limit identifier.

## Compatibility Considerations

If you previously used unsigned integer minimum data limit identifiers in custom code, for example in an S-Function, replace the limit with 0.

## Default iteration variable data type

The default data type for iteration variables in the generated code is a 32-bit integer. Previously, the default data type was `int` with an unspecified bit size.

For example, consider the following model.

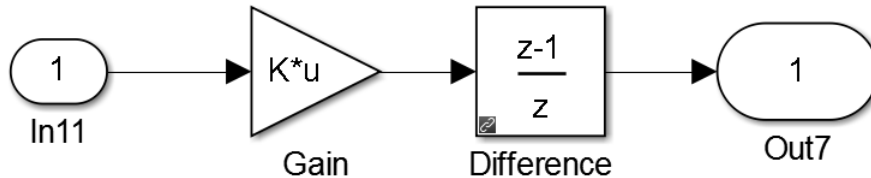

The code generator produced this code in R2014b:

```

{
  int_T i;
  for (i = 0; i < 16; i++) {
    test1_2a_Y.Out7[i].re = (0L);
    test1_2a_Y.Out7[i].im = (0L);
  }
}

```

The code generator produces this code in R2015a:

```

{
  int32_T i;
  for (i = 0; i < 16; i++) {

```

```
    test1_2a_Y.Out7[i].re = (0L);  
    test1_2a_Y.Out7[i].im = (0L);  
  }  
}
```

## Deployment

### Code Replacement Viewer enhanced

- MATLAB command for invoking the Code Replacement Viewer is renamed from `RTW.viewTfl` to `crviewer`.
- The trace information for misses that occur during the match process is reformatted as a table.

For more information, see [Verify Code Replacements](#).

### Model configuration parameter considered for division operator code replacements

When determining match criteria for division operator code replacement entries, the code generator uses model configuration parameter **Signed integer division rounds to** (`ProdIntDivRoundTo`) to determine equivalent rounding modes. For example, assume that **Signed integer division rounds to** is set to `Floor`. The code generator matches model division operations with integer rounding modes set to `simplest` or `floor` to division operator code replacement entries with the **Rounding mode** (`RoundingModes`) parameter set to `Simplest` or `Floor`.

### Lookup table algorithm parameter specification enhancements

R2015a introduces enhancements for setting algorithm parameters for lookup table function code replacement table entries.

- From the Code Replacement Tool, you can specify multiple values for an algorithm parameter.
- Programming interface improvements include:
  - Algorithm parameter set objects for discovering and managing algorithm parameter settings.
  - For a given lookup table function, default settings for unchanged algorithm parameters.
  - Validation of syntax, parameter names, and values in parameter assignment statements.

- `getAlgorithmParameters` function for examining the algorithm parameter settings for a lookup table function code replacement table entry.
- `setAlgorithmParameters` function for setting the algorithm parameters for a lookup table function code replacement table entry.

For more information, see `getAlgorithmParameters`, `setAlgorithmParameters`, and `Lookup Table Function Code Replacement`.

## Header file for Basic Linear Algebra Subroutine (BLAS) multiplication function code replacement example changed

The header file for the Basic Linear Algebra Subroutine (BLAS) multiplication function code replacement example changed from `blascompat32.h` to `blascompat32_crl.h`. The associated include path for this header file changed to `matlab/toolbox/rtw/rtwdemos/crl_demo`. For more information, see “Improved readability for shared header file ‘`rtwtypes.h`’” on page 6-13.

## Code replacement detection of overflow and rounding mode equivalence

As of R2015a, the code replacement software detects overflow and rounding mode equivalence for real scalar multiplication and division operations. When an operation does not overflow, based on input and output data types, a match occurs for code replacement table entries with the saturation mode set to **Wrap on Overflow** (`RTW_WRAP_ON_OVERFLOW`). Similarly, if the code replacement software detects equivalent rounding modes, a match occurs.

## Feature being removed in a future release

The Filter Design and Analysis Tool option to target the Code Composer Studio™ IDE will be removed in a future release. The Filter Design and Analysis Tool is available with Signal Processing Toolbox™.

## Performance

### More efficient code involving model references, unit delays, and global data references

#### Reusable custom storage class for Model block input/output ports

Previously, if a pair of root-level model input and output signals used the same `Reusable` storage class specification, the code generator could reuse the root I/O signals in the generated code. In R2015a, this optimization extends to Model block I/O signals. The code generator tries to reuse buffers for a pair of Model block I/O signals with the same `Reusable` storage class specification. This reuse can eliminate buffers in the generated code.

The input/output signals must have the same data types and sampling rates. This optimization does not apply to conditional output ports.

For more information on how to configure your model to take advantage of this optimization, see [Buffer Reuse for Model Block Boundary and Unit Delay](#).

#### Reuse input, output, and state of Unit Delay block

If any of the following conditions exist, the code generator tries to reuse the input, output, and state of a Unit Delay block:

- In the Configuration Parameters dialog box, on the **Optimizations > Signals and Parameters** pane, you select `Use global to hold temporary results` from the **Optimize global data access** list.
- You use the same `Reusable` custom storage class specification for a pair of input and state arguments or a pair of output and state arguments of a Unit Delay block.
- You use a `Reusable` custom storage class specification for a state argument of a Unit Delay block.

The reusable input, output, and state arguments must have the same data types and sampling rates. This optimization can reduce the number of global variables. For example, consider the following model.



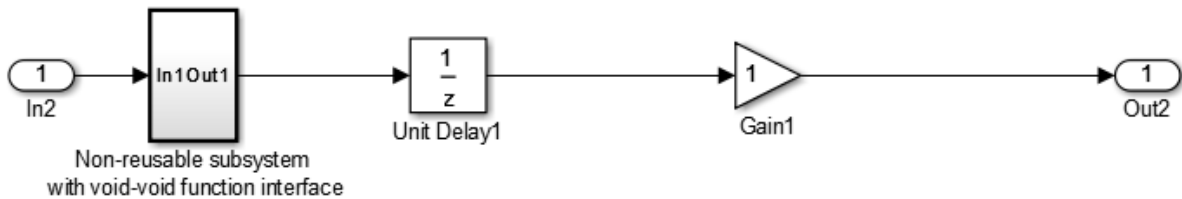

In R2014b, the code generator produces the following code:

```
DW_reuse_ex_T reuse_ex_DW;
void reuse_ex_step(void)
{
    reuse_ex_Y.Out2 = reuse_ex_P.Gain1_Gain * reuse_ex_DW.UnitDelay1_DSTATE;
    reuse_ex_Subsystem();
    reuse_ex_DW.UnitDelay1_DSTATE = reuse_ex_B.Gain2;
}

```

In R2015a, the code generator produces the following code:

```
void reuse_ex_step(void)
{
    reuse_ex_Y.Out2 = reuse_ex_P.Gain1_Gain * reuse_ex_B.Gain2;
    reuse_ex_Subsystem();
}

```

For more information on how to configure your model to use this optimization, see [Buffer Reuse for Model Block Boundary and Unit Delay](#).

### Enhanced variable reuse optimizations

The code generator has improved analysis of data copies to provide more variables for reuse and more consistent variable reuse behavior. These enhancements result in:

- Reduced data copies, code size, and RAM consumption.
- Improved execution speed.

For example, consider the following model.

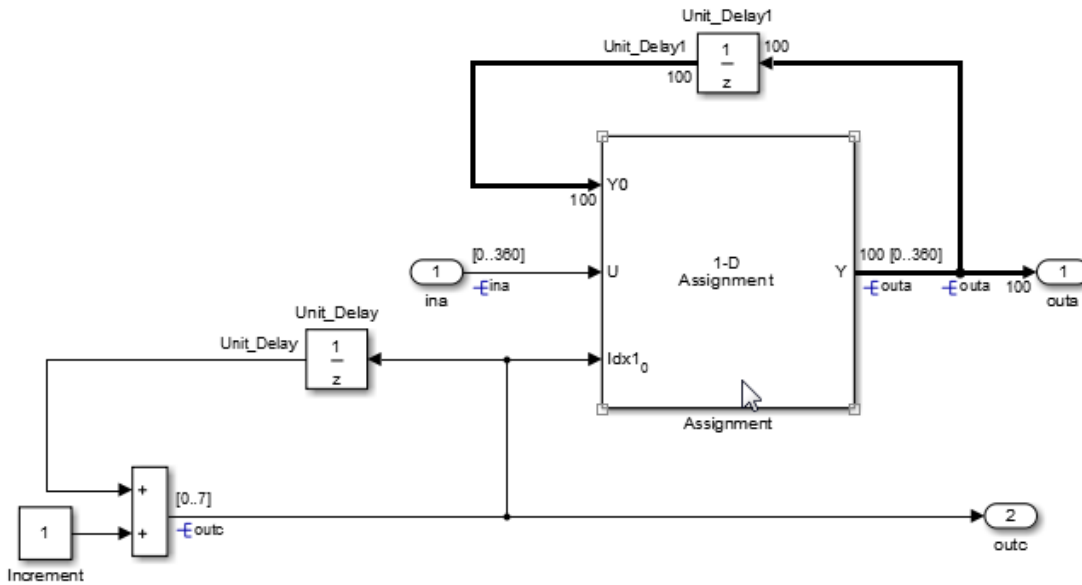

The code generator produced this code in R2014b:

```
int32_T i;

/* Sum: '<Root>/Sum' incorporates:
 * Constant: '<Root>/Increment'
 * UnitDelay: '<Root>/Unit_Delay'
 */
outc = (uint8_T)(outc + 1);

/* Assignment: '<Root>/Assignment' incorporates:
 * Inport: '<Root>/ina'
 * UnitDelay: '<Root>/Unit_Delay1'
 */
for (i = 0; i < 100; i++) {
    outa[i] = mg909420_DWork.Unit_Delay1_DSTATE[i];
}
```

```
outa[outc] = ina;

/* End of Assignment: '<Root>/Assignment' */

/* Update for UnitDelay: '<Root>/Unit_Delay1' */
for (i = 0; i < 100; i++) {
    mg909420_DWork.Unit_Delay1_DSTATE[i] = outa[i];
}
```

The code generator produces this code in R2015a:

```
outc = (uint8_T)(outc + 1);

/* Assignment: '<Root>/Assignment' incorporates:
 * Inport: '<Root>/ina'
 */
outa[outc] = ina;
```

### Strategic caching of global variable references

The code generator replaces global variables used for temporary storage with local variables. This replacement enables expression folding and other optimizations available for local variables, resulting in:

- Reduced data copies, code size, and RAM consumption.
- Improved execution speed.

For example, in the following model, the signal from a Constant block feeds into an Outport block. On the **Optimization > Signals and Parameters** pane, the **Optimize global data access** parameter is set to **Minimize global data access**.

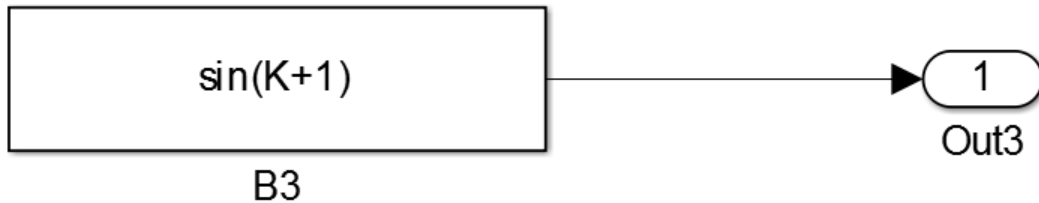

The code generator produced this code in R2014b:

```
/* Outport: '<Root>/Out3' incorporates:  
* Constant: '<Root>/B3'  
*/  
mg1003222_Y.Out3 = K + 1.0;  
mg1003222_Y.Out3 = sin(mg1003222_Y.Out3);
```

The code generator produces this code in R2015a:

```
/* Outport: '<Root>/Out3' incorporates:  
* Constant: '<Root>/B3'  
*/  
mg1003222_Y.Out3 = sin(K + 1.0);
```

### Enhanced global variable localization optimizations

The code generator has more information to determine which global variables it can replace with local variables. It can also update function interfaces to pass these local variables. With these enhancements, the code generator can:

- Enable more optimizations for local variables.
- Potentially reduce the number and use of global variables.

For example, consider the following Stateflow chart.

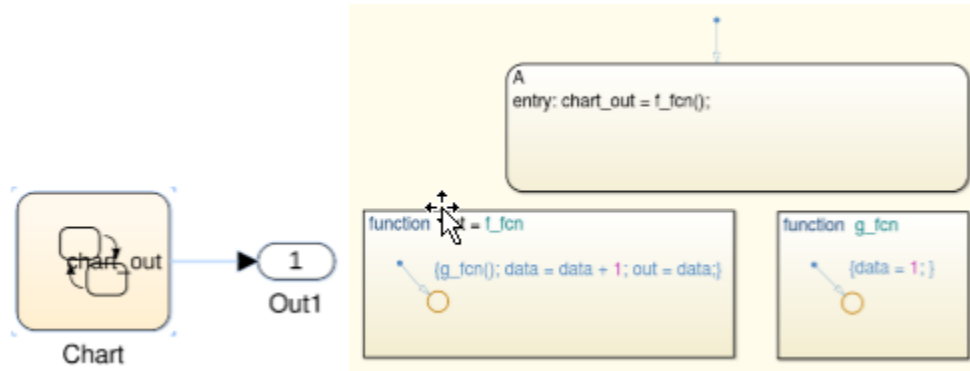

The code generator produced this code in R2014b:

```
/* Function for Chart: '<Root>/Chart' */
static real_T test_f_fcn(void)
{
    /* MATLAB Function 'f_fcn': '<S1>:5' */
    /* Graphical Function 'f_fcn': '<S1>:5' */
    /* '<S1>:10:1' */
    test_g_fcn();
    /* '<S1>:10:1' */
    test_DW.data++;
    /* '<S1>:10:1' */
    return test_DW.data;
}

```

...

```
/* Function for Chart: '<Root>/Chart' */
static void test_g_fcn(void)
{
    /* MATLAB Function 'g_fcn': '<S1>:13' */
    /* Graphical Function 'g_fcn': '<S1>:13' */
    /* '<S1>:12:1' */
}

```

```
    test_DW.data = 1.0;
}
```

The code generator produces this code in R2015a:

```
/* Function for Chart: '<Root>/Chart' */
static real_T test_f_fcn(void)
{
    real_T out;
    real_T data;
    /* MATLAB Function 'f_fcn': '<S1>:5' */
    /* Graphical Function 'f_fcn': '<S1>:5' */
    /* '<S1>:10:1' */
    test_g_fcn(&data);
    /* '<S1>:10:1' */
    out = data + 1.0;
    /* '<S1>:10:1' */
    return out;
}

...

/* Function for Chart: '<Root>/Chart' */
static void test_g_fcn(real_T *data)
{
    /* MATLAB Function 'g_fcn': '<S1>:13' */
    /* Graphical Function 'g_fcn': '<S1>:13' */
    /* '<S1>:12:1' */
    *data = 1.0;
}
```

## Conditional compilation of Data Store Memory block memory definition and declaration

When a Data Store Memory block has a non-auto storage class and variant subsystems reference the block, the code conditionally compiles the definition and declaration of the block memory. To compile, the code uses the preprocessor conditions associated with the variant subsystems. Previously, the code did not conditionally compile the definition and declaration of the block memory, resulting in the declaration and definition of global variables that the code potentially did not use.

For example, consider the following model.

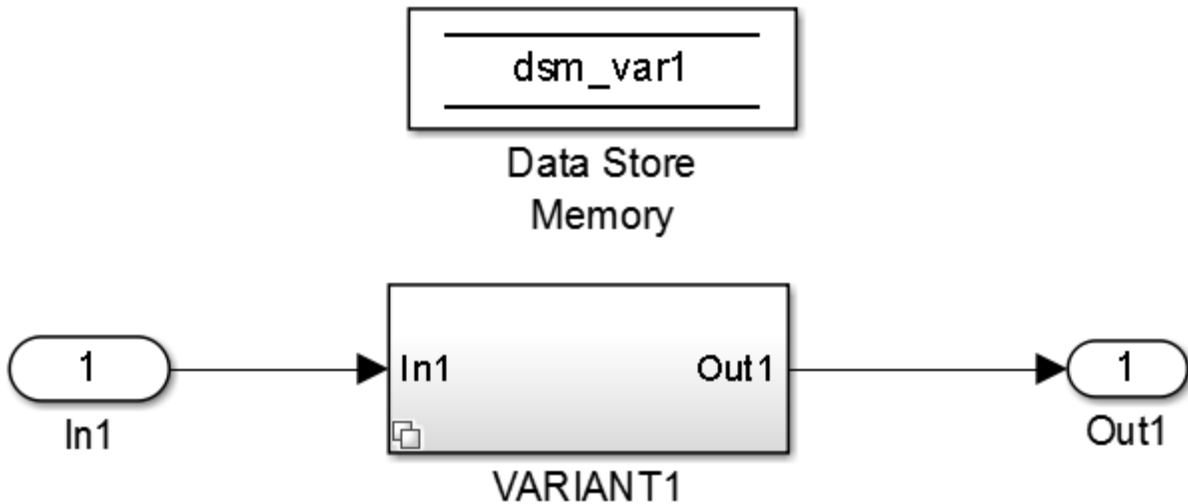

In R2014b, the code generator produces this code:

```
volatile real_T dsm_var1;
void dsm_variants_ex_initialize(void)
{
    /* custom states */
    dsm_var1 = 0.0;
}
```

In R2015a, the code generator produces code using preprocessor conditionals:

```
#if VARI1 == USE
    volatile real_T dsm_var1;
#endif /* VARI1 == USE */
void dsm_variants_ex_initialize(void)
{
    /* custom states */
    #if VARI1 == USE
        dsm_var1 = 0.0;
    #endif /* VARI1 == USE */
}
```

## **Ternary Boolean expressions transformed into assignment statements**

In R2015a, the code generator removes the conditional part of a ternary Boolean expression, leaving an assignment statement. An assignment statement in place of a ternary Boolean expression improves execution speed and reduces RAM/ROM.

Observe the following lines of code generated in R2014b:

```
uint32_T a;  
uint32_T b;  
a = (a<b)?1U:0U;
```

Compare the same lines of code generated in R2015a:

```
uint32_T a;  
uint32_T b;  
a = uint32_T(a<b);
```



## Verification

### SIL/PIL for protected models and SIL source code debugging using Microsoft Visual Studio Express

- “SIL/PIL for protected models” on page 6-31
- “SIL source code debugging using Microsoft Visual Studio Express” on page 6-32

#### SIL/PIL for protected models

To verify the behavior of code generated from protected models, use Model block software-in-the-loop (SIL) or processor-in-the-loop (PIL) simulations.

This feature supports:

- Generated code with standalone (**Top model**) and model reference (**Model reference**) code interfaces.
- AUTOSAR models, including packaged ARXML files.
- Execution-time profiling of task entry-point functions.

Description

Create a protected model(.slxp) that allows read-only view, simulation, and code generation of the model with optional password protection.

Allow user of protected model to

Open read-only view of model

Simulate

Use generated code

Code interface: **Model reference**

Content type: **Top model**

For more information, see:

- Create a Protected Model
- `Simulink.ModelReference.protect`
- Referenced Model Simulation Using SIL or PIL

## SIL source code debugging using Microsoft Visual Studio Express

Embedded Coder supports Microsoft Visual Studio® Express 2013 for Windows® Desktop for debugging code during software-in-the-loop (SIL) simulations. To specify Microsoft Visual Studio Express for SIL debugging:

- In MATLAB, select the Microsoft Windows SDK 7.1 compiler.
- On the **Configuration Parameters > Code Generation > Verification** pane, select the **Enable source-level debugging for SIL simulations** check box.

For more information, see [Debug Code During SIL Simulations](#).

## Model block SIL/PIL parameter renamed

The following SIL/PIL changes apply to the Model block:

- The command-line parameter `CodeUnderTest` is renamed `CodeInterface`.
- In the Function Block Parameters dialog box, the field **Code under test** is renamed **Code interface**.

## ERT S-Function block no longer supported for AUTOSAR

As of R2015a, to verify code generated from AUTOSAR software component, use the SIL block.

For more information, see [Verify AUTOSAR C Code with SIL and PIL](#).

## Compatibility Considerations

R2014a introduced the ability to switch between two SIL block behaviors—legacy (ERT S-function) and unified (SIL block). The software also indicated that ERT S-function support for code verification would be removed in a future release. Starting in R2015a, for AUTOSAR code generation, use the SIL block.

## SIL/PIL support for replacing `boolean` data type with `int8`

You can replace the `boolean` built-in data type with an integer type in generated code. Before R2015a, SIL and PIL execution supported data type replacement of `boolean`

with `uint8`. As of R2015a, SIL and PIL execution supports replacement of `boolean` with `uint8` or `int8`.

For more information, see [Replace boolean with Specific Integer Data Type and Data Type Replacement](#).

## **SIL/PIL support for generated access methods for C++ model class root-level I/O signals**

In the Configuration Parameters dialog box, on the **Code Generation > Interface** pane, the **External I/O access** parameter (`GenerateExternalIOAccessMethods`) specifies whether to generate access methods for root-level I/O signals for a C++ model class. Before R2015a, SIL and PIL simulations required that you set this parameter to `None`. As of R2015a, you can run SIL and PIL simulations for code that you generate with the parameter set to `Method` or `Inlined method`. These settings cause the code generator to produce noninlined or inlined access methods for the root-level I/O signals for the class.

For more information, see [External I/O access and Configure Step Method for Model Class](#).

## Check bug reports for issues and fixes

Software is inherently complex and is not free of errors. The output of a code generator might contain bugs, some of which are not detected by a compiler. MathWorks reports critical known bugs brought to its attention on its Bug Report system at [www.mathworks.com/support/bugreports/](http://www.mathworks.com/support/bugreports/). Use the Saved Searches and Watched Bugs tool with the search phrase "Incorrect Code Generation" to obtain a report of known bugs that produce code that might compile and execute, but still produce wrong answers.

The bug reports are an integral part of the documentation for each release. Examine periodically all bug reports for a release, as such reports may identify inconsistencies between the actual behavior of a release you are using and the behavior described in this documentation.

In addition to reviewing bug reports, you should implement a verification and validation strategy to identify potential bugs in your design, code, and tools.

# R2014b

**Version: 6.7**

**New Features**

**Bug Fixes**

**Compatibility Considerations**

## Code Generation from MATLAB Code

### Processor-in-the-loop (PIL) verification and execution profiling for MATLAB code

Use processor-in-the-loop (PIL) execution to verify code that you intend to deploy in production. PIL execution involves cross-compiling and running library object code on your target processor through a MATLAB PIL interface. You can reuse test vectors developed for your MATLAB functions to verify the numerical behavior of library code.

Before running PIL executions on your target hardware, specify a connectivity configuration for your target. See [PIL Customization for Target Environment and Create PIL Target Connectivity Configuration](#).

You can run a PIL execution:

- Using the MATLAB Coder Project Interface. See [Processor-in-the-Loop Execution Through Project Interface](#).
- At the command line. See [Processor-in-the-Loop Execution From Command Line](#).

Through software-in-the-loop (SIL) and processor-in-the-loop (PIL) execution, you can produce execution time profiles of code generated from entry-point functions. Use these profiles to determine:

- Whether the generated code meets real-time requirements of your target hardware.
- Which entry-point functions require performance improvement.

For more information, see [Execution Time Profiling](#).

### Software-in-the-loop verification improvements for MATLAB Coder

The following table lists software-in-the-loop (SIL) execution improvements.

Feature	R2014b support	Previous support
Code debugging during SIL execution	Linux: GNU® Data Display Debugger (DDD)	Windows: Microsoft Visual Studio debugger

Feature		R2014b support	Previous support
		Windows: Microsoft Visual Studio debugger	
Interface types	Multiple entry points	Yes	No
Size	Static variable-size arrays	Yes	Limited to function arguments that were fixed-size structures with variable-size fields.

For more information, see:

- Code Debugging During SIL Execution
- SIL/PIL Execution Support and Limitations

## Additional options for custom banners and comments in C and C++ code generated from MATLAB code

In a code generation template (CGT) file, you can now specify the following:

- Custom banners for shared utility functions
- Custom comments before individual code sections such as `Include Files` and `Function Declarations`
- doxygen style comments

The `style` attribute options for doxygen style comments are `doxygen` and `doxygen_qt`. The `TargetLang` and `CommentStyle` code configuration object properties determine the use of C or C++ style comments with the doxygen style comments.

doxygen with C style comments

```
/**
 * multiple line comments
 * second line
 */
```

doxygen with C++ style comments





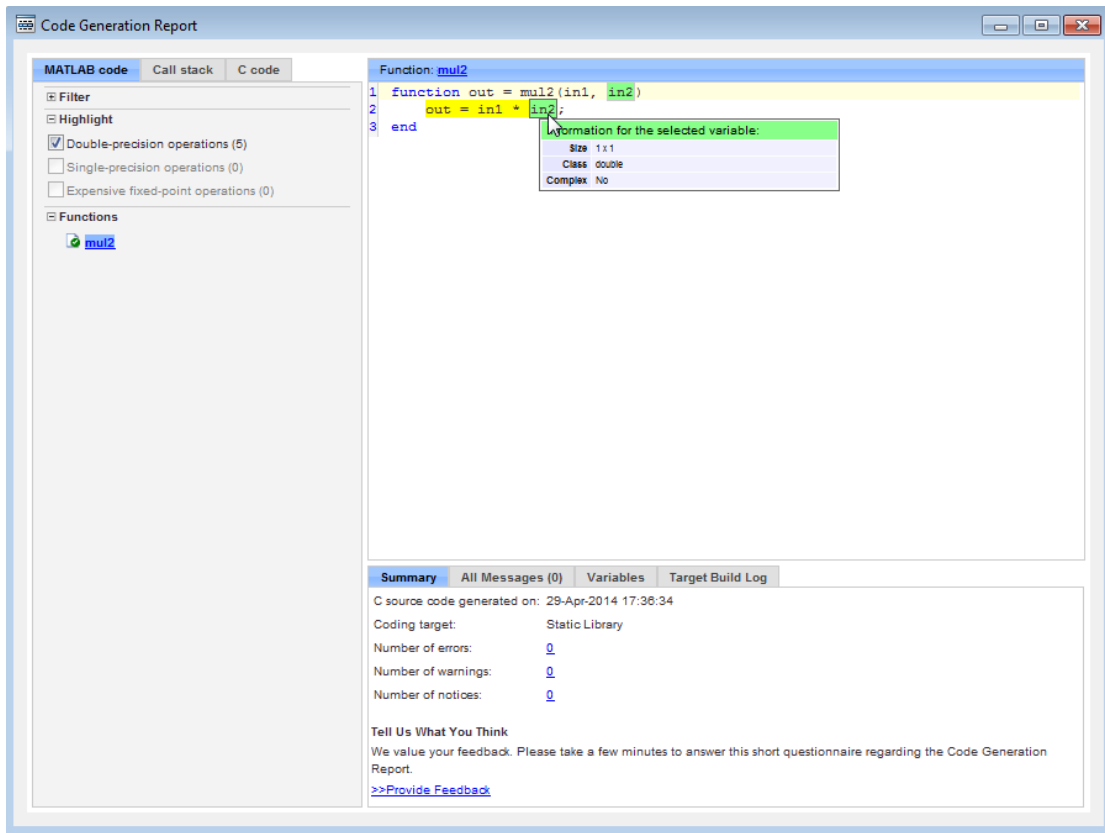

The checks are disabled by default.

To enable the checks in a project, on the **Debugging** tab, select the **Always create a code generation report** and **Highlight potential data types issues** check boxes.

To enable the checks at the command line:

- 1 Create a configuration object to generate standalone C/C++ code for an embedded target. For example:

```
cfg = coder.config('lib', 'ecoder', true);
```

- 2 Set the `HighlightPotentialDataTypeIssues` property to `true`:

```
cfg.HighlightPotentialDataTypeIssues = true;
```

See [Highlight Potential Data Type Issues in a Report and Find Potential Data Type Issues in Generated Code](#).

If you have a Fixed-Point Designer license, you have the option to highlight potential data type issues in the generated HTML report that is available after the fixed-point type validation step of the fixed-point conversion process. An Embedded Coder license is not required to highlight potential data types issues in this report. The report highlights MATLAB code that requires single-precision, double-precision, or expensive fixed-point operations.

The following example report highlights MATLAB code that requires expensive fixed-point operations.

The screenshot shows the 'Code Generation Report' window. On the left, the 'MATLAB code' tab is active, showing a list of functions: 'mul2\_fixpt' and 'mul2\_wrapper\_fixpt'. The 'Filter' section is expanded to 'Highlight', and 'Expensive fixed-point operations (1)' is checked. The main area displays the MATLAB code for 'mul2\_fixpt', with line 7 highlighted in yellow. A tooltip is visible over the code, showing the following information for the selected expression:

Size	1x1
Class	embedded::fi
Complex	No
Signedness	Unsigned
VWL	128
FL	6

At the bottom of the report, there is a 'Summary' section with the following details:

- C source code generated on: 30-Apr-2014 10:34:13
- Coding target: C MEX Function
- Number of errors: 0
- Number of warnings: 0
- Number of notices: 0

There is also a 'Tell Us What You Think' section with a link to 'Provide Feedback'.

The checks are disabled by default. To enable the checks in a project:

- 1 In the Fixed-Point Conversion Tool, click **Advanced** to view the advanced settings.
- 2 Set **Highlight potential data type issues** to **Yes**.

To enable the checks at the command line:

- 1 Create a floating-point to fixed-point conversion configuration object:

```
fxptcfg = coder.config('fixpt');
```

- 2 Set the `HighlightPotentialDataTypeIssues` property to `true`.

```
fxptcfg.HighlightPotentialDataTypeIssues = true;
```

See `Data Type Issues in Generated Code`.

## Model Architecture and Design

### **AUTOSAR targeting updates including 4.1 ARXML, client/server with Simulink Functions, multi-instance components, and IFL/IFX libraries**

R2014b provides many enhancements to AUTOSAR code generation and Simulink modeling of AUTOSAR elements. Highlights include:

- Support for AUTOSAR Release 4.1, including:
  - AUTOSAR 4.1 (schema version 4.1.1) arxml and C code generation
  - AUTOSAR 4.1 initialization events
  - AUTOSAR 4.1 provide-require ports
- Ability to model AUTOSAR clients and servers in Simulink, using Simulink Function and Function Caller blocks.
- Ability to model multi-instance AUTOSAR software components (SWCs) in Simulink, using the **Reusable function** setting of the model parameter Code interface packaging.
- AUTOSAR code replacement library support for:
  - Floating-point interpolation (IFL) and fixed-point interpolation (IFX) library routines.
  - Functions that perform a multiplication, and then a division operation in sequence.
  - Addition and subtraction operator replacements for cast-after-operation algorithms. (For more information, see “Algorithm specification for addition and subtraction operator replacement” on page 7-28.)

For more information about AUTOSAR-related enhancements in R2014b, see:

- “Support for AUTOSAR Release 4.1” on page 7-16
- “AUTOSAR client and server modeling” on page 7-9
- “Multi-instance AUTOSAR atomic software components” on page 7-17
- Code Replacement for AUTOSAR
- “Support Package for AUTOSAR Standard” on page 7-14
- “AUTOSAR help navigation enhancements” on page 7-15

## **AUTOSAR client and server modeling**

Beginning in R2014b, you can model AUTOSAR clients and servers in Simulink for simulation and code generation.

- Use Simulink Function blocks at the root level of a model to model AUTOSAR servers.
- Use Function Caller blocks to model AUTOSAR client invocations.
- Use the top-model export-functions modeling style to create interconnected Simulink functions, function-calls, and root model inports and outports.

For more information, see [Client-Server Interface and Configure AUTOSAR Client-Server Communication](#).

## **Global From and Goto blocks for AUTOSAR modeling**

Beginning in R2014b, you can use global From and Goto blocks in a model configured for AUTOSAR. With From and Goto blocks, you can pass a signal from one block to another without actually connecting them. You can model AUTOSAR runnables with more flexibility and cleaner separation of components and interfaces.

## **AUTOSAR IRV branch from output signal allowed outside runnable**

In previous releases, if you wanted to branch an AUTOSAR runnable output signal to an AUTOSAR inter-runnable variable (IRV) and a Simulink model root output, AUTOSAR code generation supported only branching inside the runnable.

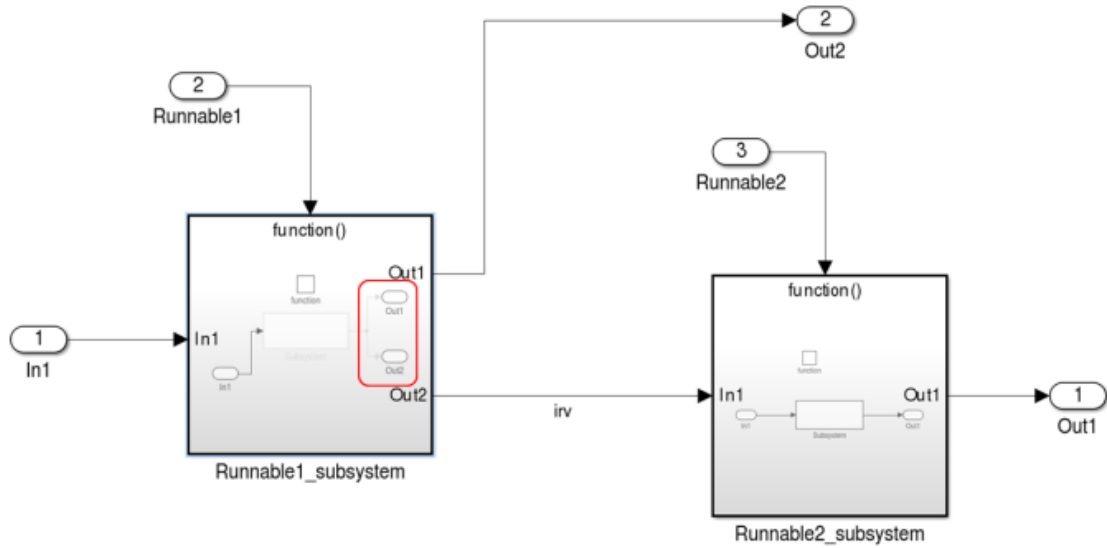

Beginning in R2014b, AUTOSAR code generation supports branching outside the runnable. This modeling pattern can potentially generate more efficient C code, for example, with fewer global variables and fewer block I/O buffers.

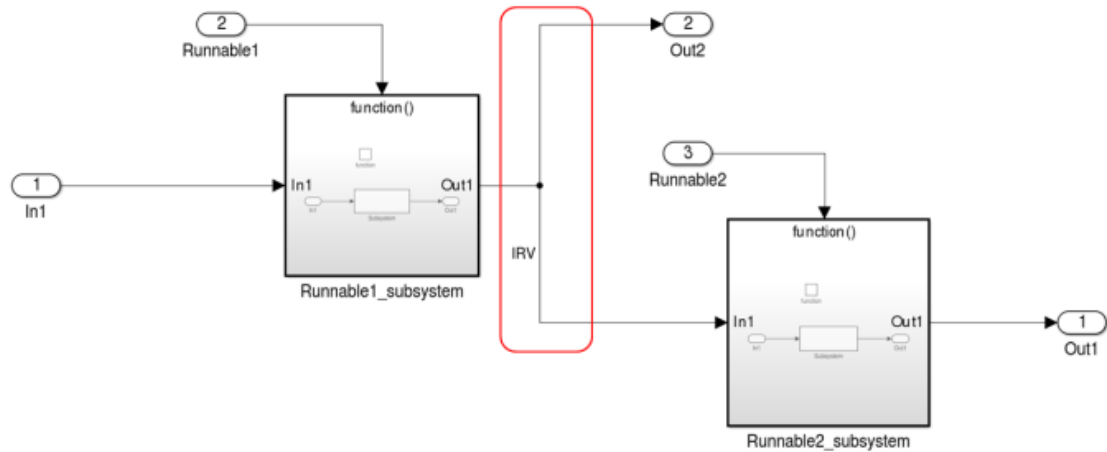

The following guidelines and constraints apply to the new modeling pattern:

- You can branch a runnable output signal to only one root output outside a runnable boundary.
- When a runnable output signal branches to an IRV and a root output outside the runnable subsystem:
  - Only Goto and From blocks are allowed between the source and the destination of the signal.
  - You cannot conditionally write to the IRV or root output.
- When a runnable output signal does not branch, only Goto/From and Merge blocks are allowed between the source and the destination of the signal.

## Data, Function, and File Definition

### Constant sample time limitation for AUTOSAR models

Previously, for models using the AUTOSAR target, the compiler reported a warning if you configured a root-level Outport block to inherit a constant sample time from its sources. The compiler then set the sample time of the root-level Outport block to the fundamental rate of the model. In R2014b, this warning becomes an error.

### Iteration variable in For Iterator block uses signal name

The code generator allows use of the signal name as part of the iteration variable name in the For Iterator block. Using the signal name increases the traceability of the generated code.

You can control the name of the iteration variable. Specify the setting for **Local temporary variables** on the **Code Generation > Symbols** pane. The signal name is the \$N part of the variable name.

Previously, the code generator used a default name, incorporating the name of the system hierarchy for the iteration variable.

See also For Iterator and Local temporary variables.

### Data type replacement specification can be used across models

When you specify data type replacement names for a model, the code generator can use the replacement types to generate shared functions and constants. You save RAM/ROM space and the code generator can use the user-defined types consistently.

For more information, see Data Type Replacement.

### Definition file for grouped custom storage classes

When defining custom storage classes of the `Struct` or `BitField` type, you can now specify the definition file for exported grouped custom storage classes.



## **Type definition location for custom storage classes**

Previously, the type definitions for data that used the `Struct` or `BitField` custom storage class were generated into the `model_types.h` header file. Now, those type definitions are generated into the same header file as that containing the data declarations (`model.h`, by default). If you specify a header file for such grouped custom storage classes, then both the type definitions and the data declarations are generated into that specified file.

## **GetFunction and SetFunction included in checks for identifier clash**

Simulink now includes the `GetFunction` and `SetFunction` properties of custom storage class attributes during checks for identifier name clashes in data objects. Previously, these properties were ignored during identifier clash detection.

## Code Generation

### Enhanced reporting of eliminated blocks

In R2014b, the **Eliminated/Virtual Blocks** section of the traceability report includes a more accurate list of blocks eliminated by optimization. For these blocks, the code can now identify if the block was eliminated by a code generation optimization or by a block reduction. The comments for these blocks are more informative and include the following changes:

- Previously, a block eliminated from a model during code generation was reported as `Not traceable`. In R2014b, the block comment is `Eliminated by code generation optimization`.
- Previously, a block eliminated by Simulink block reduction was reported as `Not traceable`. In R2014b, the block comment is the same optimization information available in the `model.h` file when you select **Code Generation > Comments > Show eliminated blocks**.
- Previously, a block eliminated by code generation or block reduction was reported as `Not traceable` in the Model Optimization Rationale column of a generated traceability matrix. In R2014b, a block eliminated by code generation has `CodeGenerationReducedBlock` in the Model Optimization Rationale column. A block eliminated by block reduction has `SimulationReducedBlock` in this column.

For more information on traceability reports, see [Customize Traceability Reports](#).

### Improved MISRA-C type cast compliance

You can choose how the code generator specifies data type casts in the generated code, including an option to choose MISRA data type cast compliance. The MISRA data type casting eliminates common MISRA standard violations, including address arithmetic and assignment. It reduces 10.1, 10.2, 10.3, and 10.4 violations.

You can also choose data type casting that is minimal or explicit.

For more information, see [Control Cast Expressions in Generated Code](#).

### Support Package for AUTOSAR Standard

Beginning in R2014b, Embedded Coder software provides add-on support for the AUTOSAR standard via the Embedded Coder Support Package for AUTOSAR

Standard. With the support package installed, you can create and modify an AUTOSAR configuration for a model, model AUTOSAR elements, and generate ARXML and AUTOSAR-compatible C code from a model.

To download and install the support package,

- 1 On the MATLAB Toolstrip, click **Add-Ons > Get Hardware Support Packages**.
- 2 Select **Install from Internet** and click **Next**.
- 3 From the list of available support packages, select **AUTOSAR Standard**.
- 4 To complete the installation, follow the instructions provided by Support Package Installer.

For more information, see Support Package Installation.

## Compatibility Considerations

AUTOSAR models and scripts that worked without a support package before R2014b now require Embedded Coder Support Package for AUTOSAR Standard. Install the support package before working with AUTOSAR models and scripts.

## AUTOSAR help navigation enhancements

To make it easier to find AUTOSAR topics within MATLAB documentation, R2014b introduces the following AUTOSAR documentation enhancements:

- New AUTOSAR landing page in MATLAB Help — Encapsulates the entire Embedded Coder AUTOSAR workflow.

### AUTOSAR

Develop AUTOSAR software components for automotive systems

#### [Modeling Patterns for AUTOSAR](#)

Modeling AUTOSAR Software Components for simulation and code generation

#### [AUTOSAR Component Creation](#)

Create Simulink® model representation of AUTOSAR software component

#### [AUTOSAR Component Development](#)

Develop and validate AUTOSAR software component

#### [AUTOSAR Code Generation](#)

Export component XML description and C code for AUTOSAR run-time environment

- New *Embedded Coder AUTOSAR* book in PDF format — Collects AUTOSAR concepts, examples, how-to topics, and reference material in a PDF file to help Simulink users learn how to model AUTOSAR components.

### [PDF Documentation for Embedded Coder](#)

[Embedded Coder Getting Started Guide](#)

[Embedded Coder User's Guide](#)

[Embedded Coder AUTOSAR](#)

[Embedded Coder Reference](#)

[Embedded Coder Release Notes](#)

## Support for AUTOSAR Release 4.1

### AUTOSAR 4.1 ARXML and C code generation

The software now supports AUTOSAR Release 4.1 (schema version 4.1.1) for import and export of arxml files and generation of AUTOSAR-compatible C code.

If you import schema version 4.1.1 arxml code into Simulink, the arxml importer detects and uses the schema version, and sets the schema version parameter in the model to 4.1.

For information on specifying an AUTOSAR schema version for code generation, see [Select an AUTOSAR Schema](#).

### AUTOSAR 4.1 InitEvent support

Beginning in R2014b, you can model AUTOSAR initialization events (`InitEvents`), as defined in AUTOSAR schema version 4.1. You can use an `InitEvent` to designate an AUTOSAR runnable as an initialization runnable, and then map an initialization function to the runnable.

In previous releases, you could use AUTOSAR mode management to set up software component initialization. For example, you could define a `ModeDeclarationGroup` with a mode for setting up and initializing a software component. `InitEvent` provides a potentially lighter-weight alternative to the mode-based approach.

If you import arxml code that describes a runnable with an `InitEvent`, the arxml importer configures the runnable in Simulink as an initialization runnable.

Alternatively, you can configure a runnable to be the initialization runnable in Simulink. For more information, see [Configure AUTOSAR Initialization Runnable](#).

### **AUTOSAR 4.1 provide-require port support**

Beginning in R2014b, you can model AUTOSAR provide-require ports (**PRPorts**), as defined in AUTOSAR schema version 4.1. **PRPorts** are a third type of port, in addition to provide ports (**PPorts**) and require ports (**RPorts**), that can be associated with an AUTOSAR sender-receiver interface. For example, you can:

- Map a Simulink inport/outport pair to a data element of an AUTOSAR provide require port. Generated code complies with Simulink and AUTOSAR semantics.
- Import AUTOSAR provide-require ports for sender-receiver interfaces from ARXML files.
- Export AUTOSAR provide-require ports to ARXML files.

For more information, see [Configure AUTOSAR Provide-Require Port](#).

### **Multi-instance AUTOSAR atomic software components**

In previous releases, AUTOSAR software components (SWCs) modeled in Simulink were single-instance. Beginning in R2014b, you can model multi-instance AUTOSAR SWCs in Simulink. For example, you can:

- Map and configure a Simulink model as a multi-instance AUTOSAR SWC, and validate the configuration.
- Generate C code with reentrant runnable functions and multi-instance RTE API calls.
- Verify AUTOSAR multi-instance C code with SIL and PIL simulations.
- Import and export multi-instance AUTOSAR SWC description XML files.

For more information and limitations, see [Multi-Instance Atomic Software Components](#).

### **AUTOSAR arxml import and export**

#### **AUTOSAR R4.x compliant data type support**

#### **AUTOSAR data types workflow improvements**

R2014b provides enhanced AUTOSAR Release 4.x compliant data type support.

- For round-trip workflows involving AUTOSAR components originated outside MATLAB, the `arxml` importer and exporter preserve data type information and mapping for each imported AUTOSAR data type.
- For AUTOSAR components originated in Simulink, the software generates AUTOSAR application, implementation, and base types to preserve the information contained within Simulink data types.

For more information, see [Release 4.x Data Types](#).

### Application data type export control

For AUTOSAR data types created in Simulink, by default, the software generates application base types only for fixed-point data types and enumerated data types with storage types.

Beginning in R2014b, if you want to override the default behavior for generating application types, you can configure the `arxml` exporter to generate an application type, along with the implementation type and base type, for each exported AUTOSAR data type. For more information, see [Control Application Data Type Generation](#).

### DataTypeMappingSet package and name control

In previous releases, for AUTOSAR software components created in Simulink, users did not have control over the AUTOSAR package and short name exported for AUTOSAR data type mapping sets. The `arxml` exporter generated the short name `DataTypeMappingSet` for every data type mapping set. The exporter used a rule-based package path that was not configurable in Simulink.

Beginning in R2014b, you can control the package and short-name for data type mapping sets. To configure the data type mapping set package for export, set the `XMLOptions` property `DataTypeMappingPackage` using the [Configure AUTOSAR Interface](#) dialog box or the `AUTOSAR` property set function. For example:

Additional Packages	
ApplicationDataType Package:	<input type="text"/>
SwBaseType Package:	<input type="text"/>
DataTypeMappingSet Package:	<input type="text" value="/pkg/dt/DataTypeMappings"/>

The exported `arxml` uses the specified package. The default mapping set short-name is the component name `ASWC` prefixed to `DataTypeMappingsSet`. You can specify a short name for a data type mapping set using the AUTOSAR property function `addPackageableElement`.

For more information, see `Configure DataTypeMappingSet Package and Name`.

### **Data initialization with `ApplicationValueSpecification`**

AUTOSAR Release 4.0 introduced application data types and implementation data types, which represent the application-level physical attributes and implementation-level attributes of AUTOSAR data types. To initialize AUTOSAR data objects typed by application data type, R4.1 requires AUTOSAR application value specifications (`ApplicationValueSpecifications`).

Beginning in R2014b, for AUTOSAR data initialization with `ApplicationValueSpecification`, Embedded Coder provides the following support:

- The `arxml` importer uses `ApplicationValueSpecifications` found in imported `arxml` files to initialize the corresponding data objects in the Simulink model.
- If you select AUTOSAR schema 4.0 or later for a model that contains AUTOSAR data typed by application data type, code generation exports `arxml` code that uses `ApplicationValueSpecifications` to specify initial values for AUTOSAR data.

### **AUTOSAR `CompuMethod` control**

#### **`CompuMethod` direction for linear functions**

In previous releases, Embedded Coder software imported AUTOSAR computational methods (`CompuMethods`) described in `arxml` code and preserved them across round-trips between an AUTOSAR authoring tool (AAT) and Simulink. For designs originated in Simulink, the `arxml` exporter created schema-compliant `CompuMethods`, but did not allow users control over `CompuMethod` attributes, including the direction of `CompuMethod` conversion between internal and physical representations of a value. For `CompuMethods` originated in Simulink, the exporter generated only the forward, internal-to-physical direction.

Beginning in R2014b, you can control how conversion direction is described in exported `CompuMethods`. Using either the `Configure AUTOSAR Interface` dialog box or the AUTOSAR property `set` function, you can specify one of the following `CompuMethod` direction values:

- **InternalToPhys** (default) — Generate **CompuMethod** sections for conversion of internal values into their physical representations.
- **PhysToInternal** — Generate **CompuMethod** sections for conversion of physical values into their internal representations.
- **Bidirectional** — Generate **CompuMethod** sections for both internal-to-physical and physical-to-internal conversion directions.

For more information, see **CompuMethod Direction for Linear Functions**.

### **CompuMethod generated for each ApplicationDataType**

In previous releases, the **arxml** exporter preserved AUTOSAR computational methods (**CompuMethods**) that you imported into Simulink, but for designs originated in Simulink, generated **CompuMethods** only for fixed point application types.

Beginning in R2014b, the exporter generates **CompuMethods** for every primitive application type. Measurement and calibration tools can monitor and interact with more application data. For more information, see **CompuMethod Categories for Data Types**.

### **Unit reference generated for each CompuMethod**

In previous releases, exported **CompuMethods** did not contain unit references. Beginning in R2014b:

- The **arxml** importer preserves unit and physical dimension information found in imported **CompuMethods**. The software preserves **CompuMethod** unit and physical dimension information across round-trips between an AUTOSAR authoring tool (AAT) and Simulink.
- For designs originated in Simulink, the exporter generates a unit reference for each **CompuMethod**.

Providing a unit for each exported **CompuMethod** helps support measurement and calibration tool use of exported AUTOSAR data. For more information, see **CompuMethod Unit References**.

### **Rational function CompuMethod for dual-scaled parameter**

R2014b provides greater control over the AUTOSAR **CompuMethods** generated for AUTOSAR dual-scaled parameters. For an AUTOSAR dual-scaled parameter, which stores two scaled values of the same physical value, the software generates the **CompuMethod** category **RAT\_FUNC**. The computation method can be a first-order rational



function. For more information, see Rational Function CompuMethod for Dual-Scaled Parameter.

### **Improved AUTOSAR package configuration**

In previous releases, the `arxml` exporter generated a fixed file and package structure for packaging AUTOSAR elements. Beginning in R2014b, Embedded Coder software provides more flexible configuration and management of AUTOSAR packages. For example:

- AUTOSAR packages and their elements now are fully preserved across round-trips between an AUTOSAR authoring tool (AAT) and Simulink.
- AUTOSAR XML options in Simulink include ten new packaging parameters (`XmlOptions` properties). You can now easily group AUTOSAR elements of the following categories into packages:
  - Application data types (schema 4.x)
  - Software base types (schema 4.x)
  - Data type mapping sets (schema 4.x)
  - Constants and values
  - Physical data constraints (referenced by application data types or data prototypes)
  - System constants (schema 4.x)
  - Software address methods
  - Mode declaration groups
  - Computational methods
  - Units and unit groups (schema 4.x)

For more information, see [Configure AUTOSAR Package Structure](#).

### **AUTOSAR calibration component export**

In previous releases, the software exported an AUTOSAR calibration component (`ParameterSwComponent`) only if it had been created in an AUTOSAR authoring tool (AAT) and imported into Simulink from an `arxml` file.

Beginning in R2014b, the software can export an AUTOSAR calibration component originated in Simulink. To configure AUTOSAR parameters for export in a calibration component, use the custom storage class (CSC) `CalPrm` with `AUTOSAR.Parameter`

data objects. For more information, see Model AUTOSAR Calibration Parameters and Configure AUTOSAR Calibration Component.

### **Simulink Min and Max mapping to AUTOSAR physical data constraints**

Beginning in R2014b, in models configured for AUTOSAR, the software maps minimum and maximum values for Simulink data to the corresponding physical constraint values for AUTOSAR application data types. Specifically:

- If you import ARXML files, `PhysConstr` values on `ApplicationDataTypes` in the ARXML files are imported to `Min` and `Max` values on the corresponding Simulink data objects and root-level I/O signals.
- When you export ARXML from a model, the `Min` and `Max` values specified on Simulink data objects and root-level I/O signals are exported to the corresponding `ApplicationDataType PhysConstrs` in the ARXML files.

### **AUTOSAR `addPackageableElement` replaces `add*Interface` functions**

R2014b introduces a new AUTOSAR property function, `addPackageableElement`, for adding packaged elements to the AUTOSAR configuration of a model. The function syntax is:

```
addPackageableElement(arProps,category,package,name)
addPackageableElement(arProps,category,package,name,property,value)
```

See the `addPackageableElement` reference page. For an example of using `addPackageableElement` as part of configuring a `DataTypeMappingSet` element for an AUTOSAR model, see “`DataTypeMappingSet` package and name control” on page 7-18.

### **Compatibility Considerations**

Using the function `addPackageableElement` with element categories `ModeSwitchInterface` or `SenderReceiverInterface` replaces the following equivalent AUTOSAR property functions:

- `addMSInterface(arProps,qName,property,value)`
- `addSRInterface(arProps,qName,property,value)`

If an existing script calls `addMSInterface` or `addSRInterface`, replace the call with an equivalent call to `addPackageableElement`. For example, consider the `addSRInterface` call in the following code:

```
open_system('rtwdemo_autosar_multirunnables');
arProps=autosar.api.getAUTOSARProperties('rtwdemo_autosar_multirunnables');
addSRInterface(arProps,'/pkg/if/Interface3','IsService',true);
ifPaths=find(arProps,[],'SenderReceiverInterface',...
    'IsService',true,'PathType','FullyQualified')
```

Replace the `addSRInterface` call with an equivalent `addPackageableElement` call.  
For example:

```
open_system('rtwdemo_autosar_multirunnables');
arProps=autosar.api.getAUTOSARProperties('rtwdemo_autosar_multirunnables');
addPackageableElement(arProps,'SenderReceiverInterface','/pkg/if','Interface3',...
'IsService',true);
ifPaths=find(arProps,[],'SenderReceiverInterface',...
    'IsService',true,'PathType','FullyQualified')
```

## Code generation report with enhanced navigation and integrated access to code metrics data

In R2014b, the following enhancements improve navigation and access to code metrics in the code generation report:

- Model-to-code navigation toolbar at the top of the code window with buttons to navigate forward and backward through the highlighted code for a model block.
- Lines in a navigation sidebar show the locations of the highlighted code in the current file. Hovering your cursor over a line shows you the code line number. Clicking the line takes you directly to the code.
- Code inspect window provides code metrics and links to definitions when you click linked variables or functions in the code.
- Hovering your cursor over global variables and functions in the code window opens a window with code metrics data.

For more information, see [Trace Model Objects to Generated Code and View Code Metrics and Definitions in the Generated Code](#).

## Updated license requirements for viewing code generation report

In 2014b, if you open a code generation report from a MATLAB menu, the software checks out the same licenses that were required when you created the report at the time of code generation. You can view the HTML report in a Web browser, but the following code generation report features are not available:

- Traceability between the code and the model.

- Code metrics data when you hover over global variables and functions in the code window.

## Compatibility Considerations

Previously, you did not need a license to view the code generation report from a MATLAB menu.

## Option for doxygen style comments in generated code

You can now specify doxygen style comments in a code generation template (CGT) file. The `style` attribute options for these comments are `doxygen`, `doxygen_cpp`, `doxygen_qt`, and `doxygen_qt_cpp`.

`doxygen` with C style comments

```
/**
 * multiple line comments
 * second line
 */
```

`doxygen_cpp` with C++ style comments

```
///
/// multiple line comments
/// second line
///
```

`doxygen_qt` with C style comments

```
/*!
 * multiple line comments
 * second line
 */
```

`doxygen_qt_cpp` with C++ style comments

```
/*!
/*! multiple line comments
/*! second line
/*!
```

For more information on using code generation template files to customize file and function banners, see [Generate Custom File and Function Banners](#).

## Dynamic memory allocation parameters renamed

On the **Code Generation > Interface** pane, two dynamic memory allocation parameters are renamed.

Code Generation > Interface pane		Command line (unchanged)
R2014b	R2014a	
Use dynamic memory allocation for model initialization	Generate function to allocate model data	GenerateAllocFcn
Use dynamic memory allocation for model block instantiation	Use operator new for referenced model object registration	UseOperatorNewForModelRefRegistration

The command line names are unchanged.

## Template makefile compatibility with execution time profiling

Consider a custom target that requires a template makefile (TMF) where the `SHARED_OBJS` definition is based on `SHARED_SRC`. If you specify code execution profiling for your model, you might observe a failure when you try to build the model. The failure occurs because the folder that contains the shared utility object files is different from the folder that contains the corresponding source code. How you fix this issue depends on how `SHARED_OBJS` is defined in your TMF. For example, you must replace:

```
SHARED_OBJS = $(SHARED_SRC:.c=.obj)
```

with:

```
SHARED_OBJS = $(SHARED_BIN_DIR)\*.obj
```

For more information, see [Customize Build to Use Shared Utility Code](#).

## Intel Performance Primitives (IPP) platform-specific code replacement libraries for cross-platform code generation

In R2014b, you can select an Intel® Performance Primitive (IPP) code replacement library for a specific platform. You can generate code for a platform that is different from the host platform that you use for code generation. The new code replacement libraries are:

- Intel IPP for x86-64 (Windows)
- Intel IPP/SSE with GNU99 extensions for x86-64 (Windows)
- Intel IPP for x86/Pentium (Windows)
- Intel IPP/SSE with GNU99 extensions for x86/Pentium (Windows)
- Intel IPP for x86-64 (Linux)
- Intel IPP/SSE with GNU99 extensions for x86-64 (Linux)

For a model that you create in R2014b, you cannot select these libraries:

- Intel IPP
- Intel IPP/SSE with GNU99 extensions

If, however, you open a model from a previous release that specifies Intel IPP or Intel IPP/SSE with GNU99 extensions, the library selection is preserved and that library appears in the selection list.

See Choose a Code Replacement Library.

## Deployment

### Embedded Coder support packages for AUTOSAR, TI Concerto, and Freescale FRDM-KL25Z

R2014b adds the following Embedded Coder support packages:

- Embedded Coder Support Package for AUTOSAR Standard — You can create and modify an AUTOSAR configuration for a model, model AUTOSAR elements, and generate ARXML and AUTOSAR-compatible C code from a model. For more information, see Support Package for AUTOSAR Standard.
- Embedded Coder Support Package for Texas Instruments C2000 F28M3x Concerto Processors — You can generate, build, and deploy code on Texas Instruments C2000 F28M35x/ F28M36x Concerto processors. For more information, see Support for Texas Instruments C2000 F28M3x Concerto Processors.
- Embedded Coder Support Package for Freescale FRDM-KL25Z Board — You can generate, build, and deploy a control algorithm on Freescale FRDM-KL25Z boards. For more information, see Support package for Freescale FRDM-KL25Z Board.

### Relational operator replacement

You can now include code replacement mappings for basic relational operators (<, <=, >, >=, ==, and !=) in custom code replacement libraries. You can apply relational operator mappings to scalar, vector, or matrix data.

For more information, see Scalar Operator Code Replacement and Small Matrix Operation to Processor Code Replacement.

### Code replacement involving vector and matrix data

- “Trigonometry function replacement” on page 7-27
- “Replacement of shift and cast operations involving vector and matrix operands” on page 7-28

#### Trigonometry function replacement

In R2014b, the C/C++ code generator supports code replacement of the following trigonometry functions for scalar, vector, and matrix input and for output arguments in code generated from:

- MATLAB functions
- MATLAB Function block
- MATLAB action language in Stateflow charts

Supported base types include floating point, complex, and noncomplex.

acos	asec	atand	cscd	sech
acosd	asecd	cos	csch	sin
acot	asech	cosd	hypot	sind
acotd	asin	cosh	log	sinh
acoth	asind	cot	log10	tan
acsc	atan	cotd	log2	tand
acscd	atan2	coth	sec	tanh
acsch	atan2d	csc	secd	

For more information, see [Map Math Functions to Application-Specific Implementations](#).

### **Replacement of shift and cast operations involving vector and matrix operands**

In R2014b, you can specify code replacements for these vector and matrix operations:

- Cast (data type conversion), RTW\_OP\_CAST
- Shift Left, RTW\_OP\_SL
- Shift Right Arithmetic, RTW\_OP\_SRA
- Shift Right Logical, RTW\_OP\_SRL

For more information, see [Small Matrix Operation to Processor Code Replacement](#).

### **Algorithm specification for addition and subtraction operator replacement**

Starting with R2014b, you can specify the algorithm—cast-before-operation (default) or cast-after-operation—for addition and subtraction operations that must be matched for operator replacement to occur.

For more information, see [Addition and Subtraction Operator Code Replacement](#).



## Compatibility Considerations

By default, the code generator attempts to replace addition and subtraction operations as cast-before-operation algorithms. This replacement matches the behavior in R2013a through R2014a. If the code generator cannot classify an operation strictly as a cast-before-operation, some replacements for non-binary-point operations do not occur. For more information, see [Addition and Subtraction Operator Code Replacement](#).

If you are using a code replacement library developed with an earlier release, verify code replacements for addition and subtraction operators. For information, see [Review and Test Code Replacements](#).

## Improved code replacement with output type cast absorption

Starting in R2014b, the code generator includes downcasts on the output of addition, subtraction, multiplication, and division operations involving real, scalar, and fixed-point data for code replacements.

For example, consider a case where `u1` and `u2` are of type `integer`. `y1` is of type `short` and the operation being replaced is `y = (short) (u1*u2)`. In previous releases, the multiplication operation was replaced without including the output cast.

```
y = (short) (my_mul_output_integer(u1, u2));
```

In R2014b, you can register an additional table replacement entry to get the following replacement:

```
y = my_mul_output_short(u1, u2);
```

The code generator does not handle intermediate casts for code replacement.

## Lookup table function code replacement extended to 30 dimensions

R2014b introduces functions `interpND` and `lookupND`. You can specify these functions to increase the dimension support of code replaced for the Interpolation Using Prelookup and n-D Lookup Table blocks to 30. The conceptual signature that you specify for the code replacement table entry depends on the number of dimensions that you want the function to support.

For more information, see [Lookup Table Function Code Replacement](#)

## Rounding mode support for lookup table function replacement

As of R2014b, the code generator supports use of algorithm parameters **Integer rounding mode** (RndMeth) and **Saturate on integer overflow** (SaturateOnIntegerOverflow) in code replacement specifications for lookup table functions.

For more information, see [Lookup Table Function Code Replacement](#).

## Algorithm parameter value sets in code replacement table entries

Prior to R2014b, code replacement table entries could specify multiple values for an algorithm parameter. However, you had to specify them in separate code replacement table entries. For example, to specify that a lookup table function with a linear or binary index search trigger a match for code replacement, you specified the following calls to `addAlgorithmProperty` in two separate table entries:

Entry 1:

```
addAlgorithmProperty('IndexSearchMethod','Linear search');
```

Entry 2:

```
addAlgorithmProperty('IndexSearchMethod','Binary search');
```

As of this release, you can specify multiple values in a single call to `addAlgorithmProperty` in one entry. Specify the value part of the parameter name-value pair as a set of string values. This specification reduces the lines of code required for more complex, conceptual specifications. For example:

```
addAlgorithmProperty('IndexSearchMethod', {'Linear search', ...  
                                             'Binary search'});
```

For more information, see [addAlgorithmProperty](#) and [Lookup Table Function Code Replacement](#).

## coder.replace support for functions specified with varargin input variable

As of R2014b, the `coder.replace` function supports MATLAB functions that specify a variable-length input argument list by using a `varargin` input variable.

For more information, see [coder.replace](#).

## Documentation installation with hardware support package

Starting in R2014b, each hardware support package has its own documentation. For a list of Embedded Coder support packages, see [Embedded Coder Supported Hardware](#).

### Support package for Altera SoC platform

You can use the Embedded Coder Support Package for Altera® SoC Platform to generate, build, and deploy code to the Altera Cyclone V SoC development kit or to the Arrow SoCKit development board. The executable runs in the Linux environment on the ARM Cortex-A9 processor on the Altera SoC platform.

See [Install Support for Altera SoC Platform](#).

For more information, see [Embedded Coder Support Package for Altera SoC Platform](#).

### Support package for BeagleBone Black hardware

You can use the Embedded Coder Support Package for BeagleBone Black Hardware to generate, build, and deploy code to the BeagleBone Black board.

See [Install Support for BeagleBone Black Hardware](#).

For more information, see [Embedded Coder Support Package for BeagleBone Black Hardware](#).

### Support for Eclipse IDE has been removed

Embedded Coder support for Eclipse™ IDE has been removed.

You can no longer use Embedded Coder with Eclipse IDE to build and run an executable on BeagleBoard hardware or ARM processors.

### Compatibility Considerations

To replace some of the capabilities provided by Eclipse IDE, consider using:

- [Embedded Coder Support Package for ARM Cortex-A Processors](#)
- [Simulink Support Package for BeagleBoard Hardware](#)

To install support packages, see supportPackageInstaller.

## **Support for Green Hills MULTI IDE has been removed**

Embedded Coder support for Green Hills® MULTI® IDE has been discontinued for R2014b.

## **Compatibility Considerations**

If you are using the Embedded Coder Support Package for Green Hills MULTI IDE, the support package is available for use with previous releases for an unspecified length of time.

## **Support for Texas Instruments C5000 DSPs will be removed**

Support for Texas Instruments C5000™ DSPs will be removed in a future release.

## Performance

### **Reduced RAM and faster execution for modeling patterns including select-assign-iterate blocks, subsystem interfaces, and model references**

- “Example Model” on page 7-33
- “In-place assignments for select-assign-iterate pattern” on page 7-35
- “Subsystem signal information” on page 7-36
- “Variable reuse around call site” on page 7-37

Code generation produces code with more optimizations, reducing RAM/ROM consumption and improving execution speed. The ability of the code generator to perform more optimizations is due to the following efficiency enhancements.

#### **Example Model**

Consider the model `example_subsys1`, that contains the subsystem and models used for the examples for each optimization:

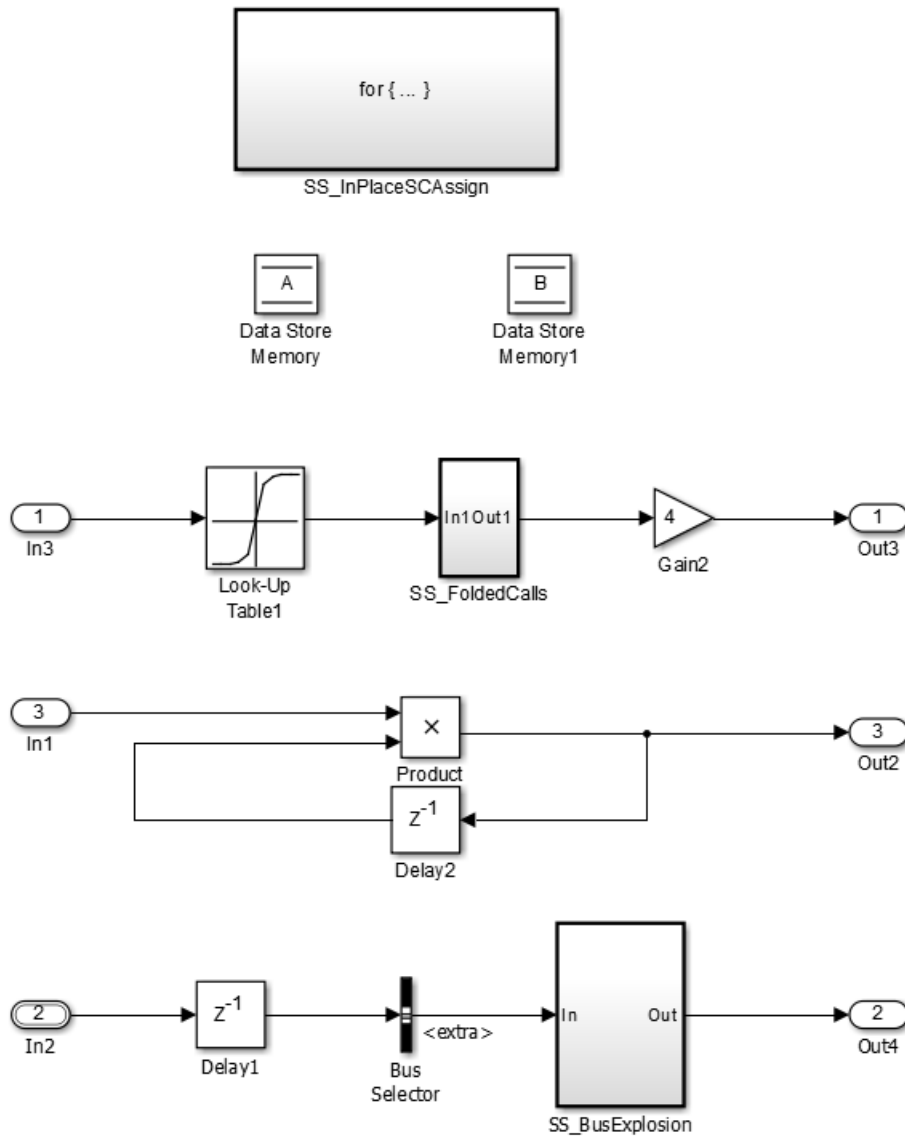

### In-place assignments for select-assign-iterate pattern

The code generator generates in-place assignments for the select-assign-iterate modeling pattern for the three subsystem function packaging options.

Example subsystem SS\_InPlaceSCAssign:

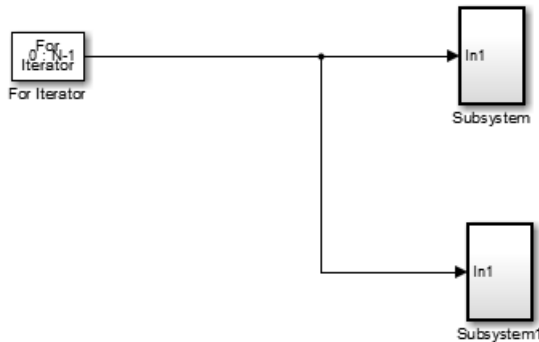

The code generator produces this code for version R2014a:

```

/* Output and update for atomic system '<S4>/Subsystem1'*/
void example_subsys1_Subsystem(int32_T rtu_In1)
{
    int32_T i;

    /* Assignment: '<S6>/Assignment' incorporates:
     * DataStoreRead: '<S6>/Data Store Read'
     */
    if (example_subsys1_Dwork.ForIterator_IterationMarker<2){
        example_subsys1_Dwork.ForIterator_IterationMarker=2U;
        for(i=0;i<30;i++){
            example_subsys1_B.Assignment[i]=example_subsys1_DWork.B[i];
        }
    }

    example_subsys1_B.Assignment[rtu_In1]=rtu_In1;

    /* End of Assignment: '<S6>/Assignment' */

    /* DataStoreWrite: '<S6>/DataStoreWrite' */
    for(i=0;i<30;i++){
        example_subsys1_DWork.B[i]=example_subsys1_B.Assignment[i];
    }
}
  
```

```

}

/* End of DataStoreWrite: '<S6>/DataStoreWrite' */
}

```

The code generator produces this code for version R2014b:

```

/* Output and update for atomic system: '<S3>/Subsystem1' */
void example_subsys1_Subsystem1(int32_T rtu_In1)
{
  /* Assignment: '<S5>/Assignment' */
  if (example_subsys1_DWork.ForIterator_IterationMarker < 2) {
    example_subsys1_DWork.ForIterator_IterationMarker = 2U;
  }

  example_subsys1_DWork.B[rtu_In1] = rtu_In1;

  /* End of Assignment: '<S5>/Assignment' */
}

```

The code generator produces less code, does not use iteration loops, and uses fewer variable references.

### Subsystem signal information

The code generator has more information about signals passing through the subsystem boundary. It uses that information to generate more fully optimized code.

The code generator generates less code for this model:

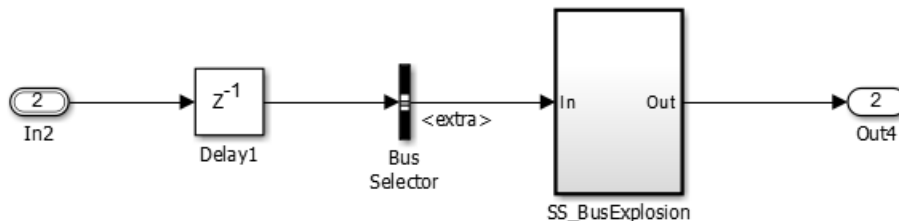

The code generator produces this code for version R2014a:

```

BigBus rtb_Delay1;
/* Delay: '<Root>/Delay1' */

```



```

rtb_Delay1 = example_subsys1_DWork.Delay1_DSTATE;

/* Outputs for Atomic SubSystem: '<Root>/SS_BusExplosion' */
example_subsys1_SS_BusExplosion(rtb_Delay1.extra);

/* End of Outputs for SubSystem: '<Root>/SS_BusExplosion' */

```

The code generator produces this code for version R2014b:

```

/* Delay: '<Root>/Delay1' */
  example_subsys1_SS_BusExplosion(example_subsys1_DWork.Delay1_DSTATE.extra);

  /* End of Outputs for SubSystem: '<Root>/SS_BusExplosion' */

```

The generated code requires fewer variables and fewer statements.

### Variable reuse around call site

The code generator reuses variables around subsystem function call sites.

Example model:

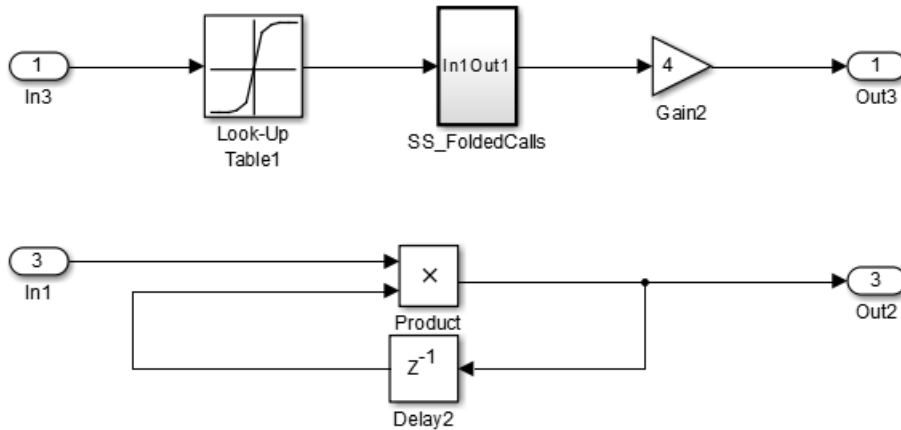

The code generator produces this code for version R2014a:

```

/* Delay: '<Root>/Delay2' */
for (i=0;i<12;i++){
  rtb_Delay2[i] = example_subsys1_DWork.Delay2_DSTATE[i];
}

```

```
/* End of Delay: '<Root>/Delay2'*/

for (i=0;i<12;i++){
  /*Product '<Root>/Product' incorporates:
   *Inport: '<Root>/In1'
   */
  rtb_Delay2_i=example_subsys1_U.In1[i]*rtb_Delay2[i];

  /*Output: '<Root>/Out2'*/
  example_subsys1_Y.Out2[i]=rtb_Delay2_i;

  /* Product '<Root>/Product'*/
  rtb_Delay2[i]=rtb_Delay2_i;
}

/*Update for Delay: '<Root>/Delay2'*/
for (i=0;i<12;i++){
  example_subsys1_DWork.Delay2_DSTATE[i] = rtb_Delay2[i];
}

/*End of Update for Delay: '<Root>/Delay2'*/
```

The code generator produces this code for version R2014b:

```
/* Product: '<Root>/Product' incorporates:
 * Delay: '<Root>/Delay2'
 * Inport: '<Root>/In1'
 */
for (rtb_DataTypeConversion = 0; rtb_DataTypeConversion < 12;
     rtb_DataTypeConversion++) {
  example_subsys1_Y.Out2[rtb_DataTypeConversion] *=
  example_subsys1_U.In1[rtb_DataTypeConversion];
}

/* End of Product: '<Root>/Product' */
```

The code generator produces much less code, including one iteration loop instead of three iteration loops. It produces fewer variable references with the same functionality.

## Global variable localization optimizations

When you generate code for a model, the code generator optimizes variable references by replacing global variables with local variables. This replacement improves execution speed and reduces RAM/ROM.

Consider this model, named `exlocal`:

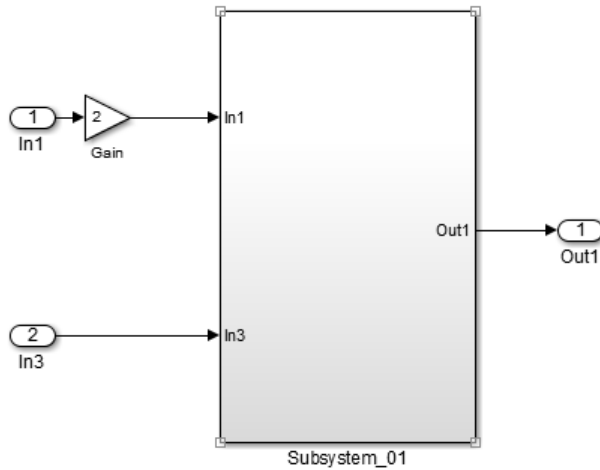

Observe the following lines of code generated for R2014a in the `exlocal_ert_rtw` folder, in the `exlocal.c` file, in the `Model` step function.

```

exlocal_B.Gain[0] = 2.0 * exlocal_U.In1[0];
exlocal_B.Gain[1] = 2.0 * exlocal_U.In1[1];
exlocal_B.Gain[2] = 2.0 * exlocal_U.In1[2];
exlocal_B.Gain[3] = 2.0 * exlocal_U.In1[3];
  
```

and

```

exlocal_Subsystem_03(exlocal_U.In3, exlocal_B.Gain, &exlocal_Y.Out1);
  
```

Compare the same lines of code generated for R2014b.

```

Gain[0] = 2.0 * exlocal_U.In1[0];
Gain[1] = 2.0 * exlocal_U.In1[1];
Gain[2] = 2.0 * exlocal_U.In1[2];
Gain[3] = 2.0 * exlocal_U.In1[3];
  
```

```

exlocal_Subsystem_03(Gain, exlocal_U.In3, &exlocal_Y.Out1);
  
```

For more information, see [Specify Global Variable Localization](#).

## Verification

### Top-model code testing with Model block SIL and PIL

You can run Model block software-in-the-loop (SIL) and processor-in-the-loop (PIL) simulations to test code that is generated from a top model. This feature enables you to use a model-based test harness to verify code for a deployable top-level component. You can create test cases, switch easily between simulation modes, and analyze numerical results.

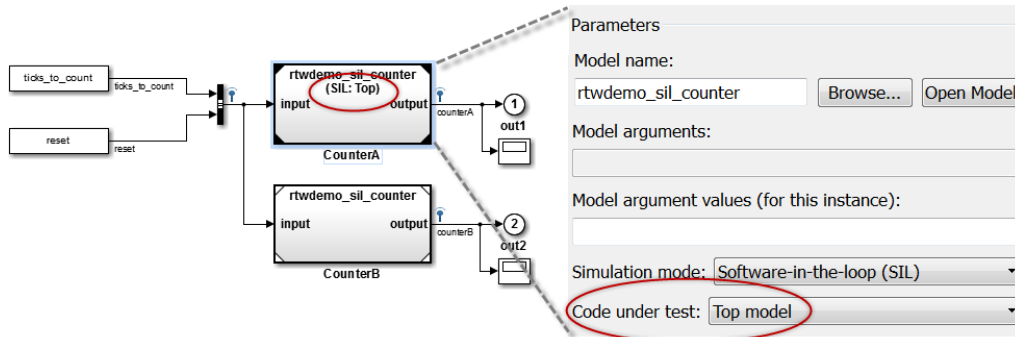

If you set the Model block parameter, **Simulation mode** (SimulationMode), to Software-in-the-loop (SIL) or Processor-in-the-loop (PIL), the software provides a new parameter **Code under test** (CodeUnderTest) with the following options:

- **Top model** — Code generated from top model, with the standalone code interface. Previously, this code was tested by running a top-model SIL or PIL simulation or by creating a SIL or PIL block.
- **Model reference** (default) — Code generated from referenced model as part of a model reference hierarchy, which was previously the only behavior available for Model block SIL and PIL.

For more information, see Referenced Model Simulation Using SIL or PIL.

### SIL/PIL support for Simulink Function and Function Caller blocks

Use top-model and Model block SIL or PIL simulations to verify code generated from models that have Simulink Function and Function Caller blocks.

The software does not support SIL or PIL block verification for these blocks. Use the Model block SIL/PIL approach, with the **Code under test** block parameter set to **Top model**.

For more information, see:

- Simulink Functions: Create and call functions across Simulink and Stateflow
- Choose a SIL or PIL Approach

## SIL debugging support for Linux

On a Linux system, you can use the GNU Data Display Debugger (DDD) to observe code behavior during a SIL simulation.

Previously, SIL debugging was available only for a Windows system.

For more information, see [Debug Code During SIL Simulations](#).

## PIL support for test hardware approach

You can run processor-in-the-loop (PIL) simulations when the **Configuration Parameters > Hardware Implementation > Test hardware is the same as production hardware** check box is not selected.

## SIL/PIL support for model initialization dynamic memory allocation

You can run SIL/PIL simulations with models that dynamically allocate memory for model data structures.

## Check bug reports for issues and fixes

Software is inherently complex and is not free of errors. The output of a code generator might contain bugs, some of which are not detected by a compiler. MathWorks reports critical known bugs brought to its attention on its Bug Report system at [www.mathworks.com/support/bugreports/](http://www.mathworks.com/support/bugreports/). Use the Saved Searches and Watched Bugs tool with the search phrase "Incorrect Code Generation" to obtain a report of known bugs that produce code that might compile and execute, but still produce wrong answers.

The bug reports are an integral part of the documentation for each release. Examine periodically all bug reports for a release, as such reports may identify inconsistencies between the actual behavior of a release you are using and the behavior described in this documentation.

In addition to reviewing bug reports, you should implement a verification and validation strategy to identify potential bugs in your design, code, and tools.

# R2014a

**Version: 6.6**

**New Features**

**Bug Fixes**

**Compatibility Considerations**

## Code Generation from MATLAB Code

### Template to customize code generation output for MATLAB Coder

You can use the `coder.MATLABCodeTemplate` class to customize code generation output for MATLAB Coder. Using a default or custom template, you can set token values to customize file banners, function banners, and file trailers.

For more information, see [Generate Custom File and Function Banners for C and C++ Code](#).

### Compatibility Considerations

Beginning in R2014a, the code generator adds file and function banners to generated code by default. If you do not specify a code generation template (CGT) file to customize the banners, the code generator uses the default template file, `matlabcoder_default_template.cgt`, in the `matlabroot/toolbox/coder/matlabcoder/templates/` folder.

### In-place function replacement with `coder.replace` in MATLAB

In R2014a, you can create code replacement table entries that specify in-place function replacement if you are generating C or C++ code from MATLAB code directly or from a MATLAB Function block. In-place code replacement is an optimization technique that uses a single buffer, that is, the same memory, to store function input and output data, as in `x=f00(x)`.

For more information, see [Specify In-Place Code Replacement and `coder.replace`](#).

### Single-line (`//`) comment style available for generated code

In earlier releases, C and C++ code generation always used a multi-line (`/*...*/`) comment style. Beginning in R2014a, you can select a single-line (`//...`) comment style for generated code.

Set the comment style in one of the following ways:

- In a project, in the Project Settings dialog box **Code Appearance** tab, set **Comment Style** to one of the following values.



Value	Description
Auto(Use standard comment style of the target language)	For C, generate multi-line comments. For C++, generate single-line comments. (default)
Single-line (Use C++-style comments)	Generate single-line comments preceded by //.
Multi-line (Use C-style comments)	Generate single or multi-line comments delimited by /* and */.

- At the command prompt, create a code generation configuration object. Set the `CommentStyle` parameter to one of the following values.

Value	Description
'Auto'	For C, generate multi-line comments. For C++, generate single-line comments. (default)
'Single-line'	Generate single-line comments preceded by //.
'Multi-line'	Generate single or multi-line comments delimited by /* and */.

For example, the following code sets the comment style to single-line comments:

```
cfg = coder.config('lib');
cfg.CommentStyle='Single-line';
```

Here is an example of generated code that uses single-line comments:

```
//
// mcadd.c
//
// Code generation for function 'mcadd'
//
```

## Software-in-the-loop verification for MATLAB Coder

The following table summarizes software-in-the-loop (SIL) execution improvements.

Feature		R2014a support	Previous support
Output type	Dynamic library	Yes	No

Feature		R2014a support	Previous support
Interface types	Constant inputs	Yes	Yes. If values passed through the SIL interface differ from the values used by the build process, the SIL execution uses the build values. The execution does not generate an error or warning.
	Constant global data	Yes. If values passed through the SIL interface differ from the values used by the build process, the SIL execution uses the build values. The execution does not generate an error or warning.	Not applicable.
Data types	Fixed-point data	Yes	Yes, with limitations.
	Multiword fixed-point data	Yes	No
	Empty values	Yes	No
Size	Static variable-size arrays	Variable-size function arguments are not supported. For function arguments that are fixed-size structures, variable-size fields are supported.	No

For more information, see [SIL Execution Support and Limitations](#).

## Change of default value for `MATLABFcnDesc`

Previously, the `MATLABFcnDesc` parameter of a `coder.EmbeddedCodeConfig` code generation configuration object had a default value of `false`. In R2014a, the default

value of the `MATLABFcnDesc` parameter is `true`. When the value of the `MATLABFcnDesc` parameter is `true`, the MATLAB function help text is included in a function banner in generated code.

## Model Architecture and Design

### **Capability to merge AUTOSAR authoring tool changes into Simulink models as part of round-trip iterations**

To help support the round trip of AUTOSAR components between an AUTOSAR authoring tool (AAT) and the Simulink design environment, R2014a adds update and merge capabilities to the `arxml` importer.

Given a Simulink model into which you have imported `arxml` code or from which you have exported `arxml` code, suppose that changes have been made to the `arxml` information in an AAT. Using the `arxml.importer` method `updateModel`, you can import the changed `arxml` information and request that the changes be merged into the model. The update/merge generates a report that details the updates applied to the model, and required changes that were not made automatically.

Here is an example of a generated AUTOSAR update report. For more information, see [Merge AUTOSAR Authoring Tool Changes Into a Model](#).

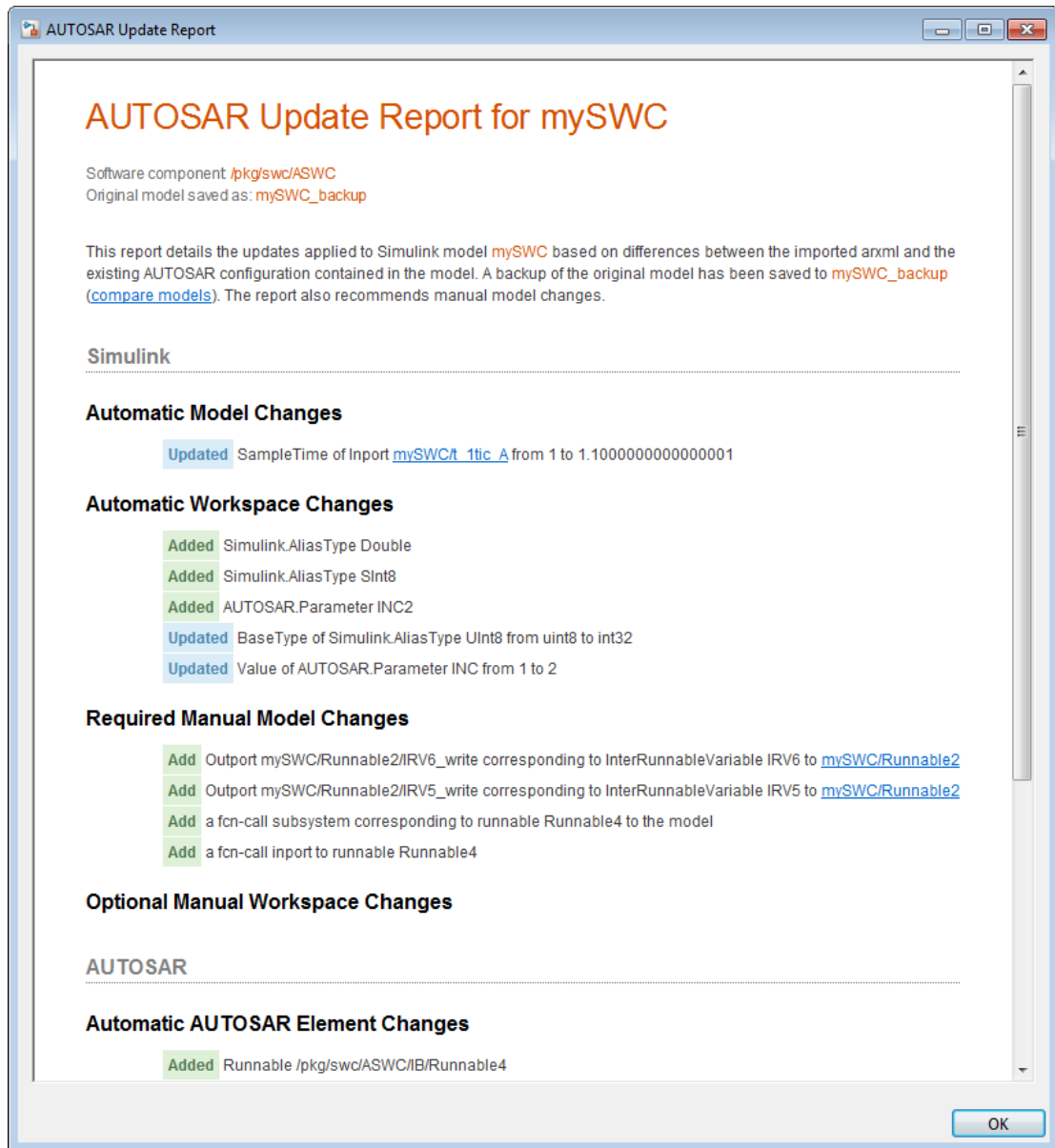

## **AUTOSAR 4.0 static and constant memory, AUTOSAR-typed per-instance memory, and VariationPointProxy**

### **Static and constant memory**

Beginning in R2014a, from a Simulink model, you can import and export AUTOSAR Static Memory and Constant Memory data, as defined by AUTOSAR schema version 4.0. Static Memory corresponds to Simulink internal global signals. Constant Memory corresponds to Simulink internal global parameters. When exported in `arxml`, Static Memory and Constant Memory allow the use of measurement and calibration tools to monitor the internal memory data.

For more information, see [Model AUTOSAR Static and Constant Memory and Configure AUTOSAR Static or Constant Memory](#)

### **AUTOSAR-typed per-instance memory**

Beginning in R2014a, you can model AUTOSAR-typed per-instance memory (`arTypedPerInstanceMemory`) in Simulink models. This class of per-instance memory was introduced in AUTOSAR schema version 4.0. You describe `arTypedPerInstanceMemory` using standard AUTOSAR data types (rather than C types). When exported in `arxml`, `arTypedPerInstanceMemory` allows the use of measurement and calibration tools to monitor the global variable corresponding to per-instance memory.

For more information, see [Model AUTOSAR Per-Instance Memory, Configure AUTOSAR Per-Instance Memory, and the example model `rtwdemo\_autosar\_PIM`](#), which has been updated to use `arTypedPerInstanceMemory`.

### **Variation point proxy**

Beginning in R2014a, you can model an AUTOSAR `VariationPointProxy`, as defined in AUTOSAR schema 4.0. The Simulink elements include:

- Variant Subsystem or Model Variant block to model a `VariationPointProxy` inside an AUTOSAR runnable.
- `AUTOSAR.Parameter` data objects to model AUTOSAR System Constants, representing the conditional values associated with the variant condition logic.
- `Simulink.Variant` data objects in the base workspace to define the variant condition logic.

For more information, see [Configure AUTOSAR Variation Point Proxies](#).

## Specify AUTOSAR runnable symbol name distinct from short-name

In previous releases, Embedded Coder derived the symbol name of an AUTOSAR runnable from the user-specified short-name. Beginning in R2014a, you can specify an AUTOSAR runnable symbol name that is distinct from the runnable short-name. The runnable symbol-name can be specified using the Configure AUTOSAR Interface dialog box or by using the AUTOSAR property functions. The specified AUTOSAR runnable symbol-name is exported in arxml and C code. Also, you can import a runnable symbol name using the arxml importer.

For example, suppose that you open the example model `rtwdemo_autosar_multirunnables`, open the Configure AUTOSAR Interface dialog box, and use the Runnables view of the AUTOSAR Properties Explorer to change the symbol-name of `Runnable1` from `Runnable1` to `test_symbol`. When you export code from the model, the symbol-name `test_symbol` appears in the exported arxml and C code as shown below.

### `rtwdemo_autosar_multirunnables.arxml`

```
<RUNNABLE-ENTITY UUID="65432c3e-34c7-5e82-4229-f6d04927eb78">
  <SHORT-NAME>Runnable1</SHORT-NAME>
  ...
  <SYMBOL>test_symbol</SYMBOL>
  ...
</RUNNABLE-ENTITY>
```

### `rtwdemo_autosar_multirunnables.c`

```
/* Output function for RootInportFunctionCallGenerator:
   '<Root>/RootFcnCall_InsertedFor_Runnable1_at_output_1' */
void test_symbol(void)
{
  ...
}
```

For more information, see

- Configure AUTOSAR Component Using AUTOSAR Properties Explorer, step 8
- API example Set Runnable Symbol Name

## Improved AUTOSAR arxml support for measurement and calibration

Embedded Coder now supports arxml import and export of the following AUTOSAR software data definition properties (SwDataDefProps):

- Software calibration access (`SwCalibrationAccess`) — Specifies measurement and calibration tool access to a data object.
- Software address method (`swAddrMethod`) — Specifies a method to access a data object (for example, a measurement or calibration parameter) according to a given address.
- Software alignment (`swAlignment`) — Specifies the intended alignment of a data object within a memory section.
- Software implementation policy (`swImplPolicy`) — Specifies the implementation policy for a data object, with respect to consistency mechanisms of variables.

In the Simulink environment, you can directly modify the `SwCalibrationAccess`, `swAddrMethod`, and `swAlignment` properties for some forms of AUTOSAR data. (You cannot modify the `swImplPolicy` property.) For more information, see [Configure AUTOSAR Data for Measurement and Calibration](#).

## AUTOSAR data dictionary support

Beginning in R2014a, you can use a Simulink data dictionary in AUTOSAR workflows. For example, you can:

- Import AUTOSAR data and parameter objects into a data dictionary, instead of into the MATLAB base workspace.
- Leverage Simulink data dictionary object properties as you edit AUTOSAR data objects.
- Export `arxml` and C code reflecting the data dictionary object properties configured for the model.

For more information about importing data and parameter objects into a data dictionary, see the `DataDictionary` property for methods `arxml.importer.createComponentAsModel` and `arxml.importer.createCalibrationComponentObjects`.

## Configure AUTOSAR Interface button removed from AUTOSAR Code Generation Options

The **Configure AUTOSAR Interface** button has been removed from the **AUTOSAR Code Generation Options** pane of the Simulink Configuration Parameters dialog box.



The remaining content of the pane pertains directly to configuring AUTOSAR arxml and C code generation.

To configure an AUTOSAR interface for a model, open the model, check that the AUTOSAR target (`autosar.tlc`) is selected for the model, and do either of the following:

- In the Simulink Editor window, select **Code > C/C++ Code > Configure Model as AUTOSAR Component**.
- In the MATLAB command window, enter the command `autosar_ui_launch(model)`.

If your model is already configured for AUTOSAR, this action opens the Configure AUTOSAR Interface dialog box. If your model is not configured for AUTOSAR, dialog boxes first help you create an AUTOSAR interface, then open the Configure AUTOSAR Interface dialog box with the initial configuration displayed.

## Subsystem methods of AUTOSAR arxml.importer class removed

Two subsystem-related methods of the `arxml.importer` class have been removed from the software:

- `arxml.importer.createComponentAsSubsystem` — Create AUTOSAR atomic software component as Simulink atomic subsystem.
- `arxml.importer.createOperationAsConfigurableSubsystems` — Create configurable Simulink subsystem library for client-server operation.

You now can model AUTOSAR multi-runnables as function-call subsystems at the top level of a model, rather than as function-call subsystems within a wrapper subsystem that represents the AUTOSAR software component.

## Compatibility Considerations

If you are using `createComponentAsSubsystem` or `createOperationAsConfigurableSubsystems`, migrate to using the top-model-oriented approach described in [Configure AUTOSAR Multiple Runnables](#).

## Data, Function, and File Definition

### Custom storage class and optimized class declarations for C++ class code generation

#### Custom storage class support for C++ class code generation

In previous releases, custom storage classes (CSCs) were not supported for C++ class code generation. Selecting **C++ (Encapsulated)** for a model forced on the model option **Ignore custom storage classes**.

Beginning in R2014a, you can use CSCs with C++ class code generation. The configuration requirements for using CSCs with C++ class code generation include the following Configuration Parameters dialog box settings:

- **Code Generation > Interface** pane:
  - Set **Code interface packaging** to **C++ class**.
  - Set **Multi-instance code error diagnostic** to a value other than **Error**.
- **Code Generation** pane: Clear the option **Ignore custom storage classes**.

For more information and limitations, see [Specify Custom Storage Class for C++ Class Code Generation](#).

#### Improved code for C++ model class declarations

R2014a enhances generated C++ model class declarations in the following ways:

- Automatically adds a copy constructor and an assignment operator to C++ class declarations when required to securely handle pointer members.
- Removes an unnecessary `rtModel` pointer declaration from C++ class declarations.

For more information, see [Model Class Copy Constructor and Assignment Operator](#).

### Constant sample time limitations for root-level Output blocks

In R2014a, the sample time of root-level Output blocks is checked in the following ways:

- For models using Function Prototype Control or a C++ class interface, the validation check reports an error if a root-level Output block has a constant sample time.

- For models using the AUTOSAR target, the compiler reports a warning if a root-level Outport block is configured to inherit a constant sample time from its sources. The compiler then sets the sample time of the root-level Outport block to the fundamental rate of the model. This warning will become an error in a future release.
- When importing an AUTOSAR model from an XML description of a single runnable, the import tool sets the sample time of root-level Outport blocks to the fundamental rate of the model.
- The Upgrade Advisor adds a check identifying root-level Outport blocks with a constant sample time. If a model uses the AUTOSAR target, Function Prototype Control, or a C++ class interface, the check lists the Outport blocks with a constant sample time. The check also includes possible actions to fix the blocks.

## **Example model `rtwdemo_cppencap` renamed to `rtwdemo_cppclass`**

As part of the C++ class code interface packaging changes described in Simulink Coder release note Improved control of C and C++ code interface packaging, C++ class example model `rtwdemo_cppencap` has been renamed to `rtwdemo_cppclass`.

## **Unit Delay block optimization**

In R2014a, when you specify a nonzero initial value or a global storage class, global block output reuse might eliminate the Unit Delay state in the generated code. Eliminating the Unit Delay state reduces data copies.

## Code Generation

### In-place function replacement with `coder.replace` in MATLAB and lookup table code replacement for Simulink

#### In-place function replacement with `coder.replace` in MATLAB

In R2014a, you can create code replacement table entries that specify in-place function replacement if you are generating C or C++ code from MATLAB code directly or from a MATLAB Function block. In-place code replacement is an optimization technique that uses a single buffer, that is, the same memory, to store function input and output data, as in `x=f00(x)`.

For more information, see [Specify In-Place Code Replacement](#) and `coder.replace`.

#### Lookup table code replacement for Simulink

In R2014a, you can replace these lookup table functions during code generation for Simulink models.

<code>interp1D</code>	<code>interp4D</code>	<code>lookup2D</code>	<code>lookup5D</code>
<code>interp2D</code>	<code>interp5D</code>	<code>lookup3D</code>	<code>lookupND_Direct</code>
<code>interp3D</code>	<code>lookup1D</code>	<code>lookup4D</code>	<code>prelookup</code>

When you create a replacement table entry for one these functions, you must specify a set of algorithm properties in addition to the usual code replacement function key, conceptual arguments, and other applicable math mode information. Specify the algorithm properties by using new algorithm property fields in the code replacement tool or the new `addAlgorithmProperty` function. Conceptual arguments and algorithm parameters must match for replacement to occur.

For more information, see [Map Lookup Table Functions to Application Implementations](#).

### Global variable usage available in the static code metrics report

The static code metrics report displays maximum reads and writes within a function and total reads and writes for each global variable and each member in a global variable data structure.

This information helps you to analyze the benefits of different global variable optimization choices. You can also compare the generated code across different versions.

For more information, see [Generate Static Code Metrics Report for Simulink Model](#).

## Single-line (//) comment style available for generated code

In earlier releases, C and C++ code generation used a multi-line (`/* ... */`) comment style. Beginning in R2014a, you can select a single-line (`// ...`) comment style for generated code using the command-line parameter `CommentStyle`. For example, the following command sets the comment style to single-line comments:

```
>> set_param('rtwdemo_counter','CommentStyle','Single-line')
```

Here is an example of code generated using the single-line comment style:

```
// Sum: '<Root>/Sum' incorporates:  
//   Constant: '<Root>/INC'  
//   UnitDelay: '<Root>/X'  
  
rtb_sum_out = (uint8_T)(1U + rtwdemo_counter_DW.X);
```

---

### Note:

- Single-line style comments and the `CommentStyle` parameter are supported only for ERT-based targets. Comment style for GRT targets is unchanged in R2014a.
  - For C, select single-line comments only if your compiler supports them.
- 

For more information, see [Specify Comment Style](#).

## Code indentation support for namespace declarations in generated code

Previously, when specifying a namespace for a model class, the generated namespace code might be incorrectly indented if you selected K&R for the **Indent style** on the **Code Generation > Code Style** pane. In R2014a, the generated namespace code follows coding standards when you select the K&R style.

## AUTOSAR C code generation enhancements

R2014a provides enhancements to AUTOSAR C code generation for AUTOSAR RTE-level data access APIs that improve efficiency and traceability of the generated C code. The changes include:

- Optimized generation of conditionally executed AUTOSAR explicit writes. A runnable can control whether an explicit RTE API call sends data element values.
- Additional traceability information in comments.
- More efficient expression folding and buffer reuse.

For example, in the following model, a constant value controls whether the software executes an explicit write.

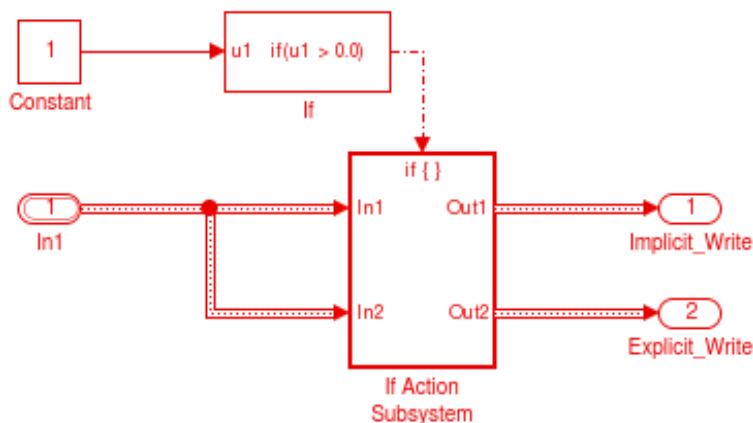

In the C code generated for the step function, an explicit send (shown in **bold**) now appears inside conditional statements.

```
void Runnable_Step(void)
{
  if (mRelease_Conditional_P.Constant_Value > 0.0)
  {
    mRelease_Conditional_B.In1 =
      *Rte_IRead_Runnable_Step_RPorts_iIn1();

    Rte_Write_PPorts_eOut2(
      Rte_IRead_Runnable_Step_RPorts_iIn1());
  }
  /* Outport: '<Root>/Implicit_Write' */
  Rte_IWrite_Runnable_Step_PPorts_iOut1(
```

```
&mRelease_Conditional_B.In1);  
}
```

## Static main program module for C++ class code generation

Beginning in R2014a, code generation supports use of a static main program module with C++ class code generated from a model. Previously, with ERT-based C++ encapsulation, code generation created an example main program and did not support use of a static main program.

In most cases, the easiest strategy for deploying generated C++ class code as a standalone program is to use the Generate an example main program option to generate the `ert_main.cpp` module. However, if you turn the **Generate an example main program** option off, you can use the module `matlabroot/rtw/c/src/common/rt_cppclass_main.cpp` as an example or template for developing your embedded applications. The module is not part of the generated code; it is provided as a basis for your custom modifications, and for use in simulation. For more information about using a static main program, see Static Main Program Module.

## Error message for data type replacement and classic call interface conflict

The model configuration options Replace data type names in the generated code (`EnableUserReplacementTypes`) and Classic call interface (`GRTInterface`) are mutually incompatible. Beginning in R2014a, if both model options are set to `on`, the model build generates an error message identifying the conflict. You must turn off one of the options.

In previous releases, if both options were set in a model reference hierarchy, build error messages did not precisely identify the conflict. The model build flagged a conflict between top and referenced models, without identifying the mutually incompatible options as the cause.

## Compatibility Considerations

Beginning in R2014a, a conflict between **Replace data type names in the generated code** and **Classic call interface** is flagged with an error. You must turn off one of the options. If you have a model reference hierarchy and your intention is to use data type replacement, turn off **Classic call interface**. Make sure data type replacement settings match throughout the hierarchy.

## Deployment

### ARM Cortex-A optimized code generation using Ne10 library

You can replace generic code with Ne10-optimized code based on the ARM Neon general-purpose SIMD engine.

To use this code replacement library with the QEMU emulator for ARM Cortex-A processors, or with the Xilinx® Zynq®-7000 platform:

- 1 Install the *Embedded Coder Support Package for ARM Cortex-A Processors*, as described in *Install Support for ARM Cortex-A Processors*.
- 2 Enable the code replacement library, as described in *Optimize Code for ARM Cortex-A Processors*.

For more information, see:

- Support Package for ARM Cortex-A Processors
- Support Package for Xilinx Zynq-7000 Platform

### Lookup table code replacement for Simulink

In R2014a, you can replace these lookup table functions during code generation for Simulink models.

interp1D	interp4D	lookup2D	lookup5D
interp2D	interp5D	lookup3D	lookupND_Direct
interp3D	lookup1D	lookup4D	prelookup

When you create a replacement table entry for one these functions, you must specify a set of algorithm properties in addition to the usual code replacement function key, conceptual arguments, and other applicable math mode information. Specify the algorithm properties by using new algorithm property fields in the code replacement tool or the new `addAlgorithmProperty` function. Conceptual arguments and algorithm parameters must match for replacement to occur.

For more information, see *Map Lookup Table Functions to Application Implementations*.



## Replacement of functions that take vector and matrix arguments

In R2014a, for Simulink Coder, you can specify code replacement conceptual arguments as vectors or matrices for these functions if the functions are generated from corresponding Simulink blocks.

abs	atanh	log	rSqrt	sincos
acosh	cos	log10	saturate	sinh
asinh	cosh	mod	sign	sqrt
atan	exp	pow	signPow	tan
atan2	hypot	rem	sin	tanh

When creating table entries for these functions, consider specifying mapping information, such as algorithm parameters and implementation attributes (for example, saturation and rounding). The additional detail helps drive expected replacement behavior. For example, data types that you observe in a model might not match what the code generator uses as intermediate data types in an operation. To verify expected function replacement, inspect the generated code.

For more information, see [Map Math Functions to Application-Specific Implementations](#).

## Logical data type support for arguments of replaced functions

In R2014a, when creating function arguments for inclusion in code replacement table entries, you can specify `logical` for the argument data type, which is equivalent to specifying `boolean`.

For more information, see [Manage Code Replacement Tables with the Code Replacement Tool and the `getTflArgFromString` function](#).

## Code replacement data alignment for complex types

The code generator now supports code replacement data alignment of complex types.

For more information, see [Configure Data Alignment for Function Implementations and `addComplexTypeAlignment`](#).

## Intel IPP (ANSI) and Intel IPP (ISO) code replacement libraries are combined

Code replacement library selections `Intel IPP (ANSI)` and `Intel IPP (ISO)` are replaced with a single library option, `Intel IPP`.

For information about setting the code replacement library, see `Code replacement library`.

## Compatibility Considerations

To specify either ANSI or ISO, use the new `Standard math library (TargetLangStandard)` parameter.

See `Standard math library`.

## Support for Eclipse IDE will be removed

Embedded Coder support for Eclipse IDE will be removed in a future release.

Currently, you can use Embedded Coder support for Eclipse IDE to:

- Build an executable from generated code on the host computer, and then run it on Linux using BeagleBoard hardware or an ARM processor.
- Build an executable from generated code on Linux using the BeagleBoard hardware (`remoteBuild`).
- Tune parameters on, and monitor data from, an executable running on the target hardware (`External mode`).
- Perform numeric verification using processor-in-the-loop (PIL) simulation.
- Generate IDE projects and use the Automation Interface API.
- Generate makefile projects using the `gcc_target` configuration in XMakefile.
- Use Linux Task block.

## Compatibility Considerations

For BeagleBoard, you can run `supportPackageInstaller` and install *Simulink Support Package for BeagleBoard Hardware*. For more information, see `BeagleBoard Hardware`.

## Support for Green Hills MULTI IDE will be removed

*Embedded Coder Support Package for Green Hills MULTI IDE* will be removed in a future release.

## Support package for ARM Cortex-A processors

You can use the *Embedded Coder Support Package for ARM Cortex-A Processors* to:

- Run executables on Linux using a QEMU emulator for ARM Cortex-A9 processors.
- Generate Ne10-optimized code based on the ARM Neon general-purpose SIMD engine.
- Tune parameters on, and monitor data from, an executable running on the QEMU (External mode).
- Verify numeric accuracy and profile execution times using processor-in-the-loop (PIL) on the QEMU.

To download and install this feature, perform the steps described in [Install Support for ARM Cortex-A Processors](#).

For more information, see:

- [Support Package for ARM Cortex-A Processors](#)
- [Support Package for Xilinx Zynq-7000 Platform](#)

## Support package for Texas Instruments C6000 processors

You can automatically generate code from Simulink models and execute it on TI's C6000 processors.

This feature includes the *Embedded Coder Support Package for Texas Instruments C6000 Processors* block library, which contains the following block libraries:

- Avnet S3ADSP DM6437 (avnet\_s3adsp\_dm6437)
- C6416 DSK (c6416dsklib)
- C6455 EVM (c6455evmlib)
- C6713 DSK (c6713dsklib)
- C6747 EVM (c6747evmlib)

- DM642 EVM (dm642evmlib)
- DM6437 EVM (dm6437evmlib)
- DM648 EVM (dm648evmlib)
- DSP/BIOS (dspbioslib)
- Optimization — C28x DMC (c28xdmclib)
- Optimization — C64x DSP Library (tic64dsplib)
- Scheduling (c6000dspcorelib)
- Target Communication (targetcommplib)

To install this support package, perform the steps described in *Install Support for C6000 DSPs*.

For more information, see *Support Package for Texas Instruments C6000 DSPs*.

## Compatibility Considerations

Previous versions of Embedded Coder software had built-in support for C6000 processors. The current version of Embedded Coder does not have built-in support for C6000 processors.

To get support for C6000 processors, install *Embedded Coder Support Package for Texas Instruments C6000 Processors*, as described in the preceding section.

## Updates to support package for Texas Instruments C2000 processors

The updated *Embedded Coder Support Package for Texas Instruments C2000 Processors*:

- Adds support for Texas Instruments Piccolo F2805x processors.
- Adds an example that shows how to use Control Law Accelerator (CLA).

To install or update this support package, perform the steps described in *Install Support for C2000 Processors*.

For more information, see *Support Package for Texas Instruments C2000 Processors*

## Updates to support package for Xilinx Zynq-7000 platform

The updated *Embedded Coder Support Package for Xilinx Zynq-7000 Platform*:

- Adds support for Xilinx Zynq-7000 All Programmable SoC ZC706 Evaluation Kit.
- Installs the *Embedded Coder Support Package for ARM Cortex-A Processors*.
- Enables use of the `ert.tlc` system target file.

To install or update this support package, perform the steps described in *Install Support for Xilinx Zynq-7000 Platform*.

For more information, see:

- *Support Package for Xilinx Zynq-7000 Platform*
- *Support Package for ARM Cortex-A Processors*

## Updates to support package for STMicroelectronics STM32F4 Discovery board

The updated Embedded Coder Support Package for STMicroelectronics STM32F4-Discovery Board:

- Adds Memory Copy block, which enables you to read from and write to memory locations on the Discovery board.
- Adds a Mic in block, which enables you to read audio data from the MEMS microphone on the Discovery board.
- Adds a Audio out block, which sends the processed audio samples to the audio output connector on the Discovery board.
- Adds support for multitasking. This means that sub-rates can finish executing after the next base rate period begins. For example, by giving sub-rates more execution time, multitasking enables audio algorithms to process larger audio buffers.

To install or update this support package, perform the steps described in *Install Support for STMicroelectronics STM32F4 Discovery Board*.

For more information, see *Support Package for STMicroelectronics STM32F4 Discovery Board*

## Wind River Tornado (VxWorks 5.x) example main program option to be removed in future release

Using the **Templates** pane of the Configuration Parameters dialog box, you can configure an ERT-based model to generate an example main program for the Wind River

Tornado® (VxWorks® 5.x) RTOS. This capability will be removed from Embedded Coder software in a future release. If you generate code with the **Templates** pane parameter **Target operating system** set to `VxWorksExample`, the software displays a warning about future removal of the VxWorks 5.x example option.

## Compatibility Considerations

In place of VxWorks 5.x support, consider using the Wind River VxWorks support package. The support package allows you to use the XMakefiles feature to automatically generate and integrate code with VxWorks 6.7, VxWorks 6.8, and VxWorks 6.9. For more information, see Support Package for Wind River VxWorks RTOS.

## Performance

### Additional options for reuse of global variables

In R2014a, on the **Optimization** pane, under **Signals and Parameters**, when you select Reuse global block outputs, the code generator reuses global variables for block outputs.

For more information, see Reuse Block Outputs in the Generated Code.

### Enhanced global variable optimization options

In R2014a, you can choose a global variable reference optimization for the generated code.

In the Configuration Parameters dialog box, on the **Optimization > Signals and Parameters** pane, the Optimize global data access drop-down list provides the following options:

- None

Use default optimizations.

- Use global to hold temporary results

Maximize use of global variables.

- Minimize global data access

Minimize use of global variables by using local variables to hold intermediate values.

With an Embedded Coder license, if you select an embedded target such as `ert.tlc`, the software replaces the **Minimize data copies between local and global variables** check box with the **Optimize global data access** list. When **Minimize data copies between local and global variables** is selected, **Optimize global data access** is set to Use global to hold temporary results.

For more information, see Optimize Global Variable Usage.

### for loops used to initialize arrays to zero

For signals with custom storage, code generation creates a `for` loop to initialize an array with matching values, such as all zeroes or ones. This initialization method reduces code

size, especially for larger arrays. Previously, the generated code initialized each element individually on a separate line.



## Verification

### Software-in-the-loop simulation for physical models

You can run software-in-the-loop (SIL) simulations of models that use Simscape™ blocks.

### SIL verification for subsystem code generation

You can use the SIL block approach to verify code generated from top-models and subsystems. In R2014a, SIL block verification supports the following features:

- Profiling of task and function execution times.
- Source-level debugging with the Microsoft Visual C++® debugger.

### Compatibility Considerations

The table describes SIL block verification features that differ from the previous release. If you want to revert to previous SIL block behavior, in the Command Window, run:

```
silblocktype('legacy');
```

To restore R2014a SIL block behavior, run:

```
silblocktype('unified');
```

Feature	R2014a Details
Validation checks	<p>The software performs, with reference to your host computer architecture, stricter checks on active <b>Hardware Implementation</b> settings. If the software detects mismatches, the software generates errors.</p> <p>For example, if your host computer is a 64-bit Linux machine, you cannot specify the following combination of settings:</p> <ul style="list-style-type: none"> <li>• <b>Device vendor:</b> Generic</li> <li>• <b>Device type:</b> 32-bit x86 compatible</li> </ul> <p>To resolve the mismatch errors, do one of the following:</p>

Feature	R2014a Details
	<ul style="list-style-type: none"> <li>• In the <b>Configuration Parameters &gt; Code Generation &gt; Verification</b> pane, select the <b>Enable portable word sizes</b> check box.</li> <li>• In the <b>Configuration Parameters &gt; Hardware Implementation</b> pane, through the <b>Production hardware</b> or <b>Test hardware</b> section, specify settings that correspond to your host computer architecture.</li> </ul> <p>The software generates an error if:</p> <ul style="list-style-type: none"> <li>• The generated code for the component under test has been updated since the creation of the SIL block.</li> <li>• The MATLAB version has changed since the creation of the SIL block.</li> </ul>
GenerateErtSFunction parameter	<p>The GenerateErtSFunction parameter has the following command-line behavior:</p> <ul style="list-style-type: none"> <li>• <code>set_param(model, 'GenerateErtSFunction', 'on')</code> generates a warning that the parameter will be removed in a future release. As a replacement, use the command <code>set_param(model, 'CreateSILPILBlock', 'SIL')</code>.</li> <li>• <code>set_param(model, 'GenerateErtSFunction', 'off')</code> does not change the parameter. As a replacement, use the command <code>set_param(model, 'CreateSILPILBlock', 'None')</code>.</li> <li>• <code>get_param(model, 'GenerateErtSFunction')</code> returns the value <code>off</code>. As a replacement, use the command <code>get_param(model, 'CreateSILPILBlock')</code>.</li> </ul>
Parameter tuning	<p>During a SIL block simulation, the software does not support the tuning of block dialog box parameters. Through the SIL block dialog box, you can view the list of tunable global parameters</p>

Feature	R2014a Details
	<p>The software does not support SIL block creation if all of the following apply:</p> <ul style="list-style-type: none"> <li>• <b>Code Generation &gt; Interface &gt; Code interface packaging</b> is set to Reusable function.</li> <li>• <b>Optimization &gt; Signals and Parameters &gt; Inline parameters</b> is not selected.</li> <li>• The model contains parameters with storage class <b>Auto</b> or <b>SimulinkGlobal</b>.</li> </ul>
Data definition and initialization	<p>In the SIL test harness, for signals that are internal with respect to the SIL block or models referenced by the SIL block, the software does not automatically define and initialize signals with imported storage classes.</p>
	<p>The software does not support automatic data definition and data transfer for local data stores in the SIL block.</p>
C++ class code (previously called C++ encapsulated code)	<p>For C++ class code:</p> <ul style="list-style-type: none"> <li>• You must set <b>External I/O access</b> parameter to None.</li> <li>• Parameters are not tunable if <b>Block parameter visibility</b> is private and <b>Block parameter access</b> is either Method or Inlined method.</li> </ul> <p>You can specify these settings through the <b>Code Generation &gt; Interface</b> pane.</p>
Code generation report	<p>The code generation report does not display test harness files for your SIL block.</p>
Multiword fixed-point data	<p>At the SIL block interface, the software does not support multiword fixed-point data types. The software supports:</p> <ul style="list-style-type: none"> <li>• At the block interface, single word data types that are wider than 32 bits.</li> <li>• Within the SIL block, multiword fixed-point data types.</li> </ul>
Boolean data type replacement	<p>At the SIL block boundary, the software does not support the replacement of the <b>boolean</b> data type by integers.</p>

Feature	R2014a Details
GetSet custom storage class	At the SIL block boundary, the software does not support vectors with the GetSet custom storage class.
Asynchronous sample times	SIL block verification does not support asynchronous sample times.
Variable-size signals	At the SIL block boundary, the software does not support variable-size signals.
AUTOSAR server operation	SIL block verification does not support AUTOSAR server operation components.

## SIL and PIL support for fixed-point data type override

At the SIL or PIL component boundary, the software supports signals with data types that are overridden by the Fixed-Point Tool **Data type override** parameter.

## SIL and PIL support for Invoke AUTOSAR Server Operation block

You can perform SIL and PIL verification of code generated from models that have Invoke AUTOSAR Server Operation blocks.

## SIL and PIL support for structure parameters with storage class `SimulinkGlobal`

The software supports the tuning of structure parameters with the `SimulinkGlobal` storage class for the following types of simulation:

- Top-model SIL and PIL
- SIL and PIL block

Previously, this feature was supported for only Model block SIL and PIL.

## Model block SIL and PIL with export-function and asynchronous function-call models

In R2014a, you can use Model block SIL and PIL simulations to verify code generated from:

- Export-function models.
- Models with asynchronous function-call inputs, that is, models that use Asynchronous Task Specification blocks.

In addition to verification, you can:

- Perform source-level debugging.
- Generate execution time profiles.
- Observe code coverage.

Model block SIL and PIL does not support models with Asynchronous Task Specification blocks if the models also have blocks that use absolute time.

## Model block SIL and PIL with disabled inline parameters

Model block SIL and PIL verification supports R2014a behavior of the `InlineParams` parameter with value `off`. For more information, see Simplified tuning of all parameters in referenced models.

## Compatibility Considerations

Consider the following simulation settings for a top model with a Model block (referenced model):

- Top-model **Simulation > Mode**: Normal
- Model block **Simulation mode**: Software-in-the-loop (SIL) or Processor-in-the-loop (PIL)
- Referenced model **Optimization > Signals and Parameters > Inline parameters (InlineParams)**: Not selected (off)

Previously, when executing the Model block in SIL or PIL mode, the software overrode the `off` value of `InlineParams` and used the `on` value. The override action does not occur in R2014a. As a result, the tuning behavior for parameters with the `Auto` storage class is the same as the tuning behavior for parameters with the `SimulinkGlobal` storage class. For more information, see Tunable Parameters and SIL/PIL.

To revert to previous behavior, you must manually set `InlineParams` to `on`.

## **SIL and PIL block improvements**

In Accelerator mode, you can run a simulation with a top model that has SIL or PIL blocks. Therefore, you can speed up simulation of your model components that are not SIL or PIL blocks.

The following features are supported for PIL block verification:

- Use of Goto and From blocks across the PIL block boundary.
- Use of virtual buses without bus objects across the PIL block boundary.
- Export of functions from triggered subsystems.

Previously, these features were supported for only SIL block verification.

## Check bug reports for issues and fixes

Software is inherently complex and is not free of errors. The output of a code generator might contain bugs, some of which are not detected by a compiler. MathWorks reports critical known bugs brought to its attention on its Bug Report system at [www.mathworks.com/support/bugreports/](http://www.mathworks.com/support/bugreports/). Use the Saved Searches and Watched Bugs tool with the search phrase "Incorrect Code Generation" to obtain a report of known bugs that produce code that might compile and execute, but still produce wrong answers.

The bug reports are an integral part of the documentation for each release. Examine periodically all bug reports for a release, as such reports may identify inconsistencies between the actual behavior of a release you are using and the behavior described in this documentation.

In addition to reviewing bug reports, you should implement a verification and validation strategy to identify potential bugs in your design, code, and tools.





# R2013b

**Version: 6.5**

**New Features**

**Bug Fixes**

**Compatibility Considerations**

## Code Generation from MATLAB Code

### Software-in-the-loop verification for MATLAB Coder

Use software-in-the-loop (SIL) execution to verify production-ready source code. SIL execution involves compiling and running static library code on your host computer. Through SIL execution, you can reuse test vectors developed for your MATLAB functions to verify the numerical behavior of static library code.

Previously, verification was restricted to code generated for execution only within MATLAB. Now, in MATLAB, you can compile and run standalone code on the host computer through a MATLAB SIL interface.

You can run a SIL execution:

- Using the MATLAB Coder project interface. See [Software-in-the-Loop \(SIL\) Execution Through the Project Interface](#).
- From the command line. See [Software-in-the-Loop \(SIL\) Execution From the Command Line](#).

### Custom generated identifiers for emxArray utility functions

You can customize generated identifiers for `emxArray` (embeddable `mxAarray`) utility functions. When you generate code that uses variable-size data, the code generation software exports utility functions to interact with `emxArray` data structures. Customize utility function identifiers to avoid name collisions when a function that uses variable-size data calls a library function that uses variable-size data.

To customize generated identifiers for `emxArray` utility functions:

- In a project

On the Project Settings dialog box **Code Appearance** tab, under **Identifier Format**, in the **EMX Array Utility Functions** field, enter the identifier format. For example, `'myemx$M$N'`.

- At the command line

Create a code generation configuration object and set the `CustomSymbolStrEMXArrayFcn` parameter to the identifier format. For example:

```
cfg = coder.config('lib');  
cfg.CustomSymbolStrEMXArrayFcn='myemx$M$N';
```

For details about the identifier format, see `coder.EmbeddedCodeConfig`.

## Model Architecture and Design

### Enhanced modeling of AUTOSAR runnables and modes, and improved ARXML import of internal behavior

R2013b enhances AUTOSAR modeling, component import, and programmatic control. See also “Support for AUTOSAR release 4.0.3 XML and generated code” on page 9-12.

#### Enhanced modeling and simulation of AUTOSAR multiple runnables

In previous releases, AUTOSAR multi-runnables were modeled as function-call subsystems within a wrapper subsystem in a Simulink model. To generate code, you right-clicked the wrapper subsystem and exported functions.

Beginning in R2013b, you can model AUTOSAR multi-runnables as function-call subsystems at the top level of a model, without having to use a wrapper subsystem. When you generate code for the model, each function-call subsystem representing a runnable appears in the model C code as a callable model entry-point function.

You can simulate multiple runnables in an AUTOSAR software component in multiple simulation modes. For example:

- For a periodic runnable, you can edit the properties of the function-call subsystem import to set the sample time for a periodic event simulation.
- For a non-periodic runnable, you can edit the **Data Import/Export** pane of the Configuration Parameters dialog box to set up data loading for an asynchronous event simulation.

For more information, see [Configure Multiple Runnables](#).

#### Enhanced ARXML import of AUTOSAR software component internal behavior

The AUTOSAR software component importer tool can automatically import the internal behavior of a multi-runnable AUTOSAR software component into a Simulink model. You can use the `createComponentAsModel` method of the class `arxml.importer` to specify that internal behavior be imported. For example:

```
>> obj = arxml.importer('mySWC.arxml');  
>> obj.createComponentAsModel('/pkg/swc', 'CreateInternalBehavior', true)
```

The importer:

- Adds subsystem blocks in the model and maps them to corresponding runnables imported from the AUTOSAR software component.
- Adds signal lines in the model and maps them to corresponding inter-runnable variables (IRVs) imported from the AUTOSAR software component.

### **Ability to model AUTOSAR mode receiver ports and events**

R2013b provides the ability to model AUTOSAR mode receiver ports and mode-switch events in Simulink. Specifically, you can:

- Model the mode receiver port for an AUTOSAR software component using a Simulink inport.
- Specify a mode-switch event to trigger an initialize function runnable or an exported function-call subsystem runnable.

For more information, see [Configure AUTOSAR Mode Receiver Ports and Events](#).

### **AUTOSAR dual-scaled parameter**

The new `AUTOSAR.DualScaledParameter` class extends the capabilities of the `AUTOSAR.Parameter` class. You can define a parameter object that stores two scaled values of the same physical value. Suppose you want to store temperature measurements as Fahrenheit or Celsius values. You can define a parameter that stores the temperature in either measurement scale with a computational method to convert between the dual-scaled values.

You can use `AUTOSAR.DualScaledParameter` objects in your model for both simulation and code generation. The parameter computes the internal value before simulation or code generation via a computational method, which can be a first-order rational function. This offline computation results in leaner generated code.

Embedded Coder also generates an XML file for use by a calibration tool. This file contains the dual-scaled values and the corresponding computational method.

For more information, see [AUTOSAR.DualScaledParameter](#).

### **Programmatic interface for configuring AUTOSAR properties and Simulink-AUTOSAR mapping**

R2013b provides a programmatic interface for configuring AUTOSAR properties and Simulink mapping information using MATLAB functions. You can programmatically get, set, add, and remove the same component properties and mapping information displayed

in the **AUTOSAR Properties Explorer** and **Simulink-AUTOSAR Mapping Explorer** views of the Configure AUTOSAR Interface dialog box.

In the function syntax, you can use fully or partially qualified names to locate properties. For example, the following code sets the `IsService` property for the sender-receiver interface located at path `Interface1` in the example model `rtwdemo_autosar_multirunnables` to `true`. In this case, specifying the name `Interface1` is enough to locate the property.

```
>> propObj = autosar.api.getAUTOSARProperties('rtwdemo_autosar_multirunnables');
>> set(propObj, 'Interface1', 'IsService', true);
```

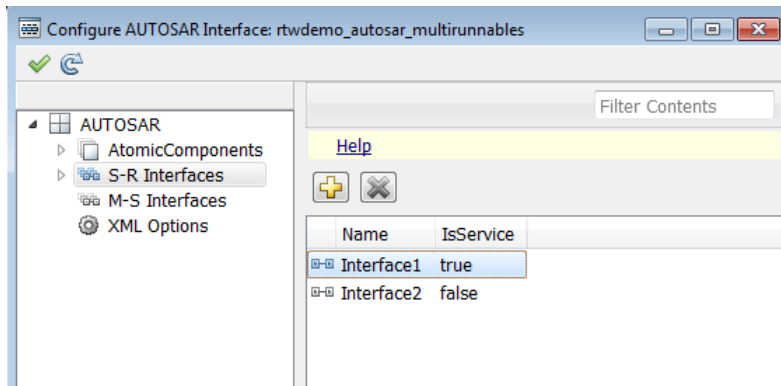

If you added a sender-receiver interface to the component, you would specify a fully qualified path, for example:

```
>> propObj = autosar.api.getAUTOSARProperties('rtwdemo_autosar_multirunnables');
>> addSRInterface(propObj, '/pkg/if/Interface3', 'IsService', true);
```

The new AUTOSAR configuration functions also validate syntax and semantics for requested AUTOSAR property and mapping changes.

## Reorganization of Model Advisor Embedded Coder checks

Checks previously provided with Simulink in the Model Advisor Embedded Coder folder are now available with either Simulink Coder or Embedded Coder. For a list of checks available with each product, see:

- Simulink Coder Checks
- Embedded Coder Checks

## Model Advisor fixed-point checks with additional coverage and optimization awareness

The Model Advisor fixed-point checks now cover blocks in base Simulink and System Toolboxes, the MATLAB Function block, System objects, Stateflow, and `fi` objects. These improved checks take into consideration model settings such as hardware configuration and code generation settings. These updated checks also avoid false negative results.

For more information, see:

- Identify blocks that generate expensive rounding code
- Identify questionable fixed-point operations
- Identify blocks that generate expensive fixed-point and saturation code

## Protected model Web view

In R2013b, a read-only Web view of protected models is now available.

To include the Web view in the protected model, right-click the model reference block, and then select **Subsystem & Model Reference > Create Protected Model for Selected Model Block**. Select the **Open read-only view of model** check box and click **Create**.

To enter a password, right-click the protected model shield icon and select **Authorize**. Enter the password and click **OK**. To show the Web view for a protected model, right-click the shield icon of the protected model and select **Show Web view**.

## RTW.AutosarInterface class to be removed in a future release

In R2013b, a new programmatic interface for configuring AUTOSAR properties and mapping information for a Simulink model has replaced the `RTW.AutosarInterface` class used in earlier releases. The `RTW.AutosarInterface` class will be removed in a future release.

## Compatibility Considerations

If you are using the `RTW.AutosarInterface` class and methods to programmatically control and validate the AUTOSAR configuration of a model, you should migrate to using

the new AUTOSAR property and mapping functions listed in AUTOSAR Component Development. The new functions are designed to work with the component properties and mapping information displayed in the **AUTOSAR Properties** Explorer and **Simulink-AUTOSAR Mapping** Explorer views of the Configure AUTOSAR Interface dialog box.

## **Subsystem methods of arxml.importer class to be removed in a future release**

Beginning in R2013b, you can model AUTOSAR multi-runnables as function-call subsystems at the top level of a model, rather than as function-call subsystems within a wrapper subsystem that represents the AUTOSAR software component. The following methods of the arxml.importer class will be removed in a future release:

- arxml.importer.createComponentAsSubsystem — Create AUTOSAR atomic software component as Simulink atomic subsystem
- arxml.importer.createOperationAsConfigurableSubsystems — Create configurable Simulink subsystem library for client-server operation

## **Compatibility Considerations**

If you are using `createComponentAsSubsystem` or `createOperationAsConfigurableSubsystems`, you should migrate to using the top model oriented approach described in [Configure Multiple Runnables](#).



## Data, Function, and File Definition

### Simplified global types file `rtwtypes.h` with invariant content

Previously, during rebuilds of a model hierarchy, the code generation process might have updated the content of the shared header file `rtwtypes.h`. If a model in the hierarchy changed, or the code generator detected a new model in the hierarchy, `rtwtypes.h` could be overwritten. When `rtwtypes.h` changes, you must recompile the code.

In R2013b, the code generator separates some of the `rtwtypes.h` content into separate header files that are generated only when certain model settings or components are present. Separate header files are generated, however, `rtwtypes.h` is unchanged. When certain model settings or components are present, the code generator creates the following new header files.

Model setting or component	Content generated to header file
Multiword data types	<code>multiword_types.h</code>
Model reference target	<code>model_reference_types.h</code>
Model reference blocks	<code>model_reference_types.h</code>
MAT-file logging is selected	<code>builtin_typeid_types.h</code> <code>multiword_types.h</code>
C API	<code>builtin_typeid_types.h</code>
Interface is set to External mode	<code>multiword_types.h</code>

For more information on files created during code generation, see [Files Created During the Build Process](#).

### C++ encapsulation support for name space control and template-based file customization

#### Name space control for scoping C++ encapsulated model classes

R2013b adds name space control for scoping model classes generated using C++ encapsulation. You can use the **Namespace** parameter in the Configure C++ Encapsulation Interface dialog box to specify a name space for a model class. If specified, the name space is emitted in the generated code for the model class. To scope the C++

encapsulated model classes in a model reference hierarchy, you can specify a different name space for each referenced model. For more information, see [Use Name Spaces to Scope C++ Encapsulated Model Classes](#).

For more information on configuring C++ encapsulated model classes, see [Configure C++ Encapsulation Interfaces Using Graphical Interfaces](#).

### Template-based customization of encapsulated C++ header and source files

Embedded Coder now supports the **Code Generation > Templates** pane of the Configuration Parameters dialog box for models that use C++ encapsulation. You can use the code and data templates to control the appearance of C++ code in generated model header and source files. For example, you can customize file and function banners to meet organization standards.

However, the following template file features that are supported for other language selections are not supported for C++ encapsulation:

- Free-form text outside template sections
- Custom tokens
- TLC commands (<! > tokens)

### Shared utility naming control

You can customize a shared utility name. On the **Code Generation > Symbols** pane enter text and formatting characters in the **Shared utilities** box.

The default token string is \$N\$C.

Token	Description
\$N	The code generator inserts the shared utility function name.
\$C	When the combined text and utility name exceed the maximum identifier length, the code generator inserts an eight-character conditional checksum. This checksum ensures that the name is unique.

If the shared utility identifier exceeds the maximum length, characters are deleted from \$N and the eight-character conditional checksum is inserted.

For more information see

- Shared utilities
- Identifier Format Control
- Exceptions to Identifier Formatting Conventions

## Expanded support for identifier names

When specifying temporary local variables, you can now use **\$A** to insert the data type acronym into your variable name. This capability provides you with a more consistent naming scheme.

- You can include **\$A** in naming for local temporary variables where previously it was supported only for local block output variables and field names of global types. For more information, see Identifier Format Control, Local temporary variables and Field name of global types.
- You can customize identifier names by specifying **\$A** which maps to the data type replacement setting. Previously the generated code changed the types, but not the identifier names. For more information, see Data Type Replacement.

## Terminate function setting honored for subsystems and referenced models

In previous releases, model builds did not uniformly honor the setting of the model option **Terminate function required** when generating code for subsystems or referenced models. A model build could generate termination code for a subsystem or referenced model when **Terminate function required** was cleared.

Beginning in R2013b, model builds honor the setting of **Terminate function required** for subsystems and referenced models. When **Terminate function required** is cleared, the build suppresses subsystem and referenced model termination code.

## Compatibility Considerations

If an existing model relies on subsystem or referenced model termination code being generated despite the model option **Terminate function required** being cleared, consider turning on the **Terminate function required** option.

## Code Generation

### Support for AUTOSAR release 4.0.3 XML and generated code

R2013b adds AUTOSAR release 4.0.3 support, as follows:

- ARXML import and export support AUTOSAR release 4.0.3 XML files.
- The AUTOSAR target generates AUTOSAR release 4.0.3 compliant C code.
- Selecting the value **4.0** for the AUTOSAR model parameter **Generate XML file** from schema version now selects schema revision 4.0.3, rather than 4.0.2. Also, the parameter now defaults to value **4.0**, rather than **3.0** or an earlier version.

See also “Enhanced modeling of AUTOSAR runnables and modes, and improved ARXML import of internal behavior” on page 9-4.

### Indent style and size control for code generation

R2013b adds options for customizing code appearance. The following new parameters are located in the Configuration Parameters dialog box, on the **Code Generation > Code Style** pane.

- **Indent style:** Specify **K&R** or **Allman** style for the placement of braces.
- **Indent size:** Specify the number of characters per indent level. Choose from **2–8** characters.

For more information on configuring code style parameters, see [Control Code Style](#).

### Subsystem functions return value in generated code

In the Subsystem Block Parameters dialog box, on the **Code Generation** tab, if you specify

- The **Function packaging** parameter for your subsystem to **Nonreusable function**
- The **Function interface** parameter to **Allow arguments**

The code generator might generate a subsystem function that returns a scalar output value. Previously, subsystem functions returned `void`.

## **Model reference step function void input and output arguments**

Since R2010a, when a reusable subsystem fed the output, code generation might create output arguments for model reference step functions.

In R2013b, code generation produces model reference step functions with void input and void output when the model reference block:

- Is a single instance.
- Has exported globals on its input and output ports.

## Deployment

### ARM Cortex-M optimized code with STM32F4-Discovery board example

Build ARM Cortex-M optimized executables from Simulink models. Automatically run executables on STMicroelectronics STM32F4-Discovery boards.

---

**Note:** In addition to the basic math optimizations provided by *Embedded Coder Support Package for ARM Cortex-M Processors*, you can obtain advanced optimizations for ARM DSP filters using the *DSP System Toolbox™ Support Package for ARM Cortex Processors*. For more information, see the DSP System Toolbox release notes for R2013b.

---

#### Support package for ARM Cortex processors

Use the *Embedded Coder Support Package for ARM Cortex-M Processors* to:

- Build and run CMSIS-optimized executables on ARM Cortex-M QEMU emulator.
- Use the capabilities and features described in Supported Features for ARM Cortex-M Processors

To download and install this feature, perform the steps described in Install Support for ARM Cortex-M Processors.

For more information, see the Support Package for ARM Cortex-M Processors topic.

#### Support package for STMicroelectronics STM32F4-Discovery Board

Use the Embedded Coder Support Package for STMicroelectronics STM32F4-Discovery Board to automatically build (makefile-based), download, and run an executable on Discovery board processors.

Use blocks from the Embedded Coder Support Package for STMicroelectronics STM32F4-Discovery Board block library:

- ADC — Convert analog signal to digital signal.
- GPIO Read — Configure input pin to read pin status.
- GPIO Write — Configure output pin to output pin status.

This support package automatically installs the following third-party software:

- STM32F4DISCOVERY peripheral firmware examples <http://www.st.com/internet/evalboard/product/252419.jsp>
- OpenOCD <http://www.freddiechopin.pl/en/download/category/4-openocd>
- GNU Tools for ARM Embedded Processors <https://launchpad.net/gcc-arm-embedded>
- QEMU <http://lassauge.free.fr/qemu/>
- CMSIS <http://www.arm.com/products/processors/cortex-m/cortex-microcontroller-software-interface-standard.php>

To download and install this support package, perform the steps described in Install Support for STMicroelectronics STM32F4 Discovery Board.

For more information, see the Support Package for STMicroelectronics STM32F4 Discovery Board topic.

## Wind River VxWorks 6.9 support

You can automatically generate code from Simulink models and execute it on VxWorks 6.9 RTOS.

To use this feature, install the corresponding support package:

- 1 In a MATLAB Command Window, enter `supportPackageInstaller`.
- 2 Use Support Package Installer to install the *Embedded Coder Support Package for Wind River VxWorks RTOS*.

This feature includes the Embedded Coder Support Package for Wind River VxWorks RTOS block library, which contains the following blocks:

- UDP Send and UDP Receive — Enable UDP communication with networked devices using an Ethernet port.
- VxWorks Task — Spawn task function as a separate VxWorks thread.

For more information, see the Support Package for Wind River VxWorks RTOS topic.

### Compatibility Considerations

Previous versions of Embedded Coder software had built-in support for the VxWorks 6.7 and 6.8. The current version of Embedded Coder does not have built-in support for VxWorks 6.7 and 6.8. To get support for VxWorks 6.7, 6.8, and 6.9, install the *Embedded Coder Support Package for Wind River VxWorks RTOS*.

## Support package for Texas Instruments C2000 processors

You can automatically generate code from Simulink models and execute it on Texas Instruments C2000 processors.

To use this feature, install the corresponding support package:

- 1 In a MATLAB Command Window, enter `supportPackageInstaller`.
- 2 Use Support Package Installer to install *Embedded Coder Support Package for Texas Instruments C2000 Processors*.

This feature includes the Embedded Coder Support Package for Texas Instruments C2000 Processors block library, which contains:

- C2802x (c2802xlib) block library
- C2803x (c2803xlib) block library
- C2806x (c2806xlib) block library
- C280x (c280xlib) block library
- C281x (c281xlib) block library
- C2834x (c2834xlib) block library
- C28x3x (c2833xlib) block library
- Memory Operations block library
- Optimization — C28x DMC (c28xdmclib) block library
- Optimization — C28x IQmath (tiiqmathlib) block library
- RTDX Instrumentation (rtdxBlocks) block library
- Scheduling block library
- Target Communication block library

For more information about this feature, see the [Support Package for Texas Instruments C2000 Processors](#) topic.

### Compatibility Considerations

Previous versions of Embedded Coder software had built-in support for C2000 processors. The current version of Embedded Coder does not have built-in support for C2000 processors.



To get support for C2000 processors, install *Embedded Coder Support Package for Texas Instruments C2000 Processors*, as described in the preceding section.

## Coder Target pane in Configuration Parameters dialog box

You can use the Coder Target pane to configure target hardware settings for your model.

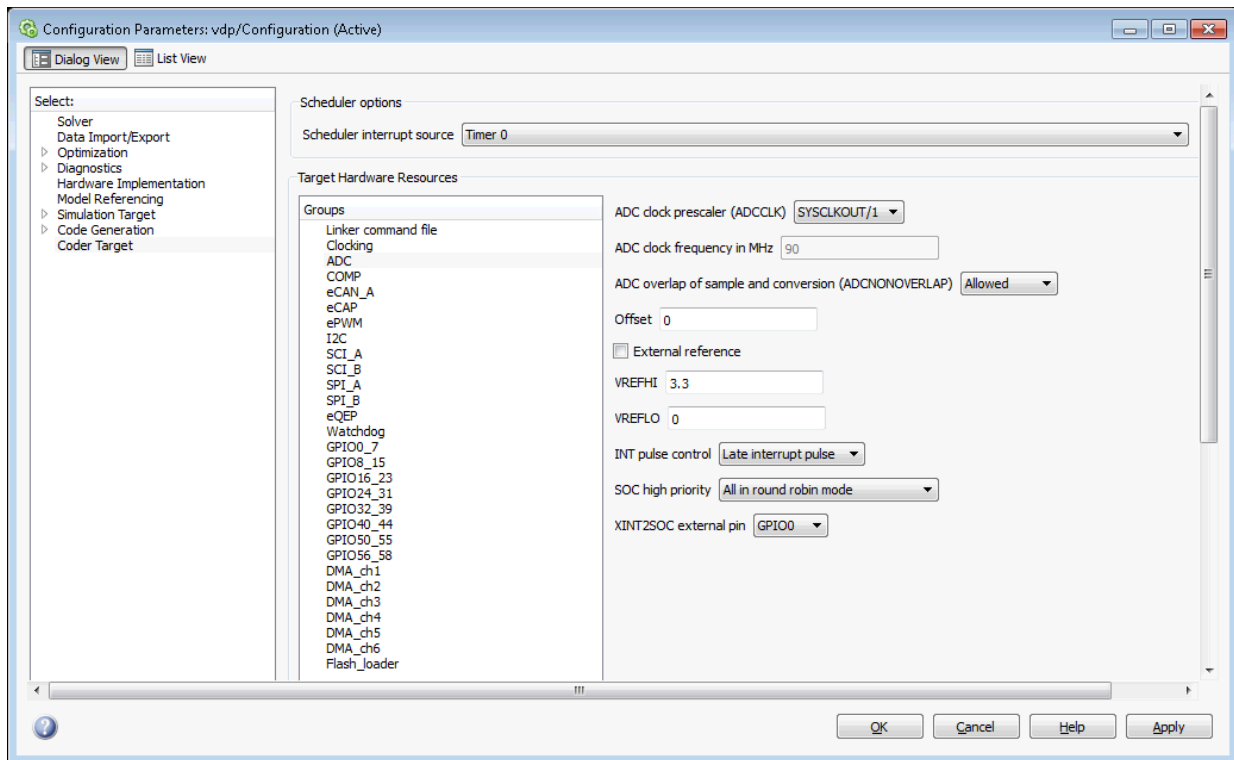

This Coder Target pane has the same name as the Code Generation > Coder Target sub-pane that appears when the **System target file** parameter is `idelink_ert.tlc` or `idelink_grt.tlc`.

To use the Coder Target pane:

- 1 Open Configuration Parameter dialog box by entering **Ctrl+E**.
- 2 Select the Code Generation pane.

- 3 Set the **System target file** parameter to `ert.tlc`. Click **Apply**.
- 4 Set the **Target hardware** parameter to match your target hardware.

The Configuration Parameters dialog box displays the Coder Target pane with parameters for the specified target hardware.

## ZedBoard hardware support

You can automatically generate code from Simulink models and execute it on ZedBoard™ hardware. Specifically, you can execute the code in the Linux environment on the ZedBoard's ARM Cortex-A9 processor.

To use this feature, install the corresponding support package:

- 1 In a MATLAB Command Window, enter `supportPackageInstaller`.
- 2 Use Support Package Installer to install *Embedded Coder Support Package for Xilinx Zynq-7000 Platform*.

This feature includes the Embedded Coder Support Package for Xilinx Zynq-7000 Platform block library, which contains:

- UDP Send and UDP Receive — Enable UDP communication with networked devices using an Ethernet port.
- Linux Task — Spawns task function as separate Linux thread.

For more information, see the Support Package for Xilinx Zynq-7000 Platform topic.

---

**Note:** For more information about using HDL Coder™ software with the FPGA on the Avnet® ZedBoard hardware, see [IP core integration into Xilinx EDK project for ZC702 and ZedBoard](#)

---

## Simplified multi-instance code interface and dynamic memory allocation for ERT targets

Embedded Coder now provides a simplified multi-instance code interface, with a dynamic memory allocation option, for ERT-based models. The new capabilities support easier integration of multi-instance code into applications. The new interface to generated model code features:

- Use of a single model entry-point function argument for instance data such as signals, states, parameters, and optionally root-level input and output.
- Configurable argument list for model root-level input and output.
- Option to generate a function that dynamically allocates memory for model instance data.

For more information, see model option `Generate reusable code`, `Entry-Point Functions and Scheduling`, and `Generate Reentrant Code from a Top-Level Model`.

For an example of an ERT-based model configured to generate reusable, reentrant code, see the example model `rtwdemo_reusable`.

## Compatibility Considerations

Beginning in R2013b, when you select **Generate reusable code** for an ERT-based model, model data structures, such as Block I/O, DWork, and Parameters, are packaged into the real-time model data structure. The real-time model data structure is passed in a single argument to the model entry-point functions `model_initialize`, `model_step`, and `model_terminate`.

In earlier releases, when you selected **Generate reusable code** for an ERT-based model, model data structures were passed in separately as arguments to the model entry-point functions. The number of generated arguments varied, depending on the data requirements of the model.

If you have code that calls reusable code generated from ERT-based models, you should update the model entry-point function calls to use the new, simplified interface.

For example, consider model entry-point functions previously called as follows:

```
/* Step the model */
rtwdemo_reusable_step(&rtP, &rtDWork, rtU_In1, rtU_In2, &rtY_Out1);

/* Initialize model */
rtwdemo_reusable_initialize();
```

In R2013b or later, the corresponding calls might be as follows:

```
/* Step the model */
rtwdemo_reusable_step(rtM, rtU_In1, rtU_In2, &rtY_Out1);

/* Initialize model */
```

```
rtwdemo_reusable_initialize(rtM);
```

Beginning in R2013b, after selecting **Generate reusable code**, you also can select the model option **Generate function to allocate model data**, which generates a function to dynamically allocate memory (using `malloc`) for model data structures. If you do not select this option, the model instance data must be allocated either statically or dynamically by the calling code. For this case, an additional requirement beginning in R2013b is that pointers to the individual data structures (such as Block IO, DWork, and Parameters) must be set up in the top-level real-time model data structure.

## Addition and Subtraction Operator Code Replacement Assumes Cast-Before-Operation Behavior

The type of algorithm that addition and subtraction operators apply for a given math library can be characterized as cast-before-operation (CBO) or cast-after-operation (CAO). In the CBO case, prior to performing the operation, the algorithm type casts input values to the output type. If the output data type cannot exactly represent the input values, losses can occur as a result of the cast to the output type. Additional loss can occur when the result of the operation is cast to the final output type.

In the CAO case, the algorithm computes the ideal result of the operation on the inputs and then type casts the result to the output data type. Loss occurs during the type cast. This algorithm behaves similarly to the C language except when the signedness of the operands does not match. For example, when you add a signed long operand to an unsigned long operand, standard C language rules convert the signed long operand to an unsigned long operand. The result is a value that is not ideal.

Starting in R2013b, the code generator assumes CBO behavior for replacement code defined for addition and subtraction operators.

## Compatibility Considerations

In previous releases, the code replacement software did not take the Sum block configuration into account when making a replacement. Starting in R2013b, the code replacement software considers the Sum block for replacement if the block meets the CBO constraint. To meet that constraint, the block must be configured in one of the following ways:

- Input and output are the same type and the size of the accumulator type is equal to or greater than the size of that type

- Input and output types differ, but the size of the accumulator type is equal to the size of the output type

If the Sum block does not meet the CBO constraint, a replacement that occurred in a previous release might not occur.

Addition functions in libraries that implement full-precision addition, such as the ANSI C library, are not suitable as replacement functions.

When using code replacements, validate that the numerical results of the generated code match the results of a processor-in-the-loop (PIL) simulation.

## Performance

### Reusable custom storage class to reduce root I/O memory

In R2013b, if a pair of root-level model input and output signals uses the same storage class specification, code generation can reuse the root I/O signals in the generated code. The storage class specifications are the new custom storage class `Reusable(Custom)` or a custom storage class created from `Reusable(Custom)`. Reusing code for root input and output signals allows for further optimizations that reduce data copies, global variables, and ROM/RAM size. For more information, see [Signal Reuse for Root-Level Model Inputs and Outputs](#).

### Subsystem functions reused independently of output connection

Previously, code generation used different criteria to determine when to reuse code.

- Code generation used the connection status to help determine the number of subsystem functions to generate.
- Code generation reused subsystem functions with varied connection status only when the outputs were passed by structure reference.

Code generation can now reuse subsystem functions regardless of:

- The connection state of the outputs. You can specify multiple outputs as `unconnected` or `terminated` across subsystems.
- Whether the reusable system outputs are passed as `Structure reference` or `Individual arguments`.

## Verification

### SIL and PIL support fixed-point data types wider than 32 bits

Use software-in-the loop (SIL) and processor-in-the-loop (PIL) simulations to verify generated code that contains fixed-point data types wider than 32 bits.

A number of host and target platforms support 64-bit native data types. On these platforms, implementing a fixed-point data type wider than 32 bits as a single word is more efficient than the multiword fixed-point approach. Previously, data types wider than 32 bits, including multiword fixed-point, were supported internally within a SIL or PIL component. However, the data types were not supported in the communication between the MATLAB and Simulink host and the SIL or PIL component on the target. Now, the software supports 33-bit to 64-bit single word, fixed-point data types in host-target communication.

Data types that SIL and PIL support include the following:

- 64-bit `long` and `long long`
- 64-bit execution profiling timer data type — Previously, the target returned only the 32 least significant bits to the MATLAB host, with the possibility of timer wrapping.
- `int64` and `uint64` — Used in MATLAB Coder SIL execution.

The following constraints apply:

- For 64-bit data type support, the data type must be representable as `long` or `long long` on the MATLAB host *and* the target. Otherwise, the software uses the multiword fixed-point approach, which SIL and PIL do not support.
- 32-bit Windows does not support 64-bit `long` or `long long` data types. In this case, the software uses the multiword fixed-point approach which SIL and PIL do not support.
- The software does not support the 40-bit `long` data type of the TI's C6000 target.

Through the **Configuration > Hardware Implementation** pane, you can enable support for the 64-bit `long long` data type. However, for data types with widths between 33 and 40 bits (inclusive), the software implements the data types using the 40-bit `long` data type which SIL and PIL do not support.

## SIL and PIL protected model support

Software-in-the-loop (SIL) or processor-in-the-loop (PIL) simulation modes are now supported for protected models. You can run models that contain protected models in SIL and PIL simulation modes if the protected models support code generation. In previous releases, the only supported simulation modes were Normal and Accelerator.

## Code execution profiling improvements

### Standalone code generation with function profiling

You can generate executable code (**Ctrl+B**) for your model even if function profiling is enabled. The software produces the following warning message:

```
Warning: Code profiling instrumentation is not supported for standalone builds (Ctrl+B). You can run the executable, but no profiling data will be collected.
```

Previously, if function profiling was enabled for a SIL or PIL simulation, building your model produced an error message. For example:

```
Code profiling instrumentation within the generated code is not supported for top model standalone builds (Ctrl+B). You cannot build the top model rtwdemo_sil_modelblock in standalone mode because rtwdemo_sil_modelblock has code profiling instrumentation enabled. You must either simulate rtwdemo_sil_modelblock in SIL or PIL mode or disable code profiling instrumentation for rtwdemo_sil_modelblock. To disable code profiling instrumentation, clear the check box Simulation > Configuration Parameters > Code Generation > Verification > Measure function execution times.
```

For information about obtaining execution time profiles for generated code, see [Code Execution Profiling](#).

### Display of code section invocations

You can display code section invocations over the execution timeline.



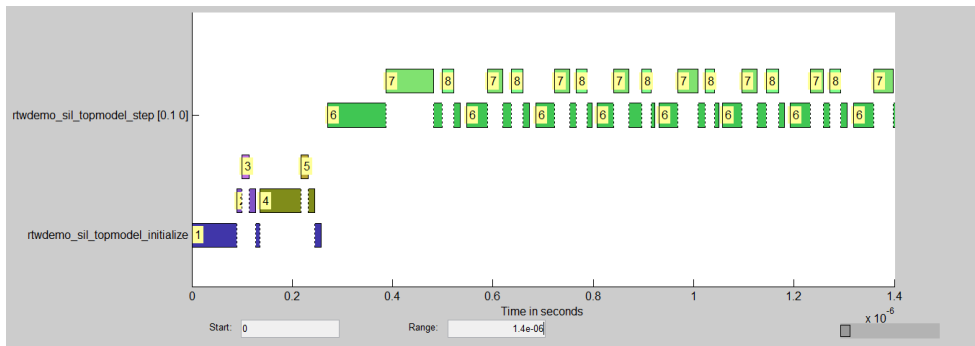

For more information, see timeline.

### **SampleOffset and SamplePeriod removed**

The `coder.profile.ExecutionTimeSection` `SampleOffset` and `SamplePeriod` methods have been removed.

## Check bug reports for issues and fixes

Software is inherently complex and is not free of errors. The output of a code generator might contain bugs, some of which are not detected by a compiler. MathWorks reports critical known bugs brought to its attention on its Bug Report system at [www.mathworks.com/support/bugreports/](http://www.mathworks.com/support/bugreports/). Use the Saved Searches and Watched Bugs tool with the search phrase "Incorrect Code Generation" to obtain a report of known bugs that produce code that might compile and execute, but still produce wrong answers.

The bug reports are an integral part of the documentation for each release. Examine periodically all bug reports for a release, as such reports may identify inconsistencies between the actual behavior of a release you are using and the behavior described in this documentation.

In addition to reviewing bug reports, you should implement a verification and validation strategy to identify potential bugs in your design, code, and tools.

# R2013a

**Version: 6.4**

**New Features**

**Bug Fixes**

**Compatibility Considerations**

## Code Generation from MATLAB Code

### Improved code replacement traceability for MATLAB code generation

In the R2013a release, there is now improved code replacement traceability for standalone code generated using MATLAB Coder. This capability is not available for generated MEX functions. When you choose to include code replacements in the code generation report:

- The code generation report includes a link to the Code Replacements Report.
- Code replacement trace information is generated for viewing in the **Trace Information** tab of the Code Replacement Viewer.
- The code replacement report lists replacement functions and their associated MATLAB code.

You can use the code replacement report to:

- Determine which replacement functions were used in the generated code.
- Trace each replacement instance back to the MATLAB code that triggered the replacement.

For more information, see [Enable the Code Replacements Report and Viewing Code Replacements in the Generated Code](#).

### Static code metrics report for MATLAB Coder

When you generate standalone C code with MATLAB Coder, the HTML code generation report now includes a static code metrics report. The static code metrics report is not available for generated MEX functions.

The static code metrics include the:

- Number of source code files.
- Number of lines of code.
- List of global variables.
- Functions in a call tree format.
- Estimated stack size required for a function.

You can use the information in the static code metrics report to:

- Find the number of files and lines of code in each file.
- Estimate the number of lines of code and stack usage per function.
- Compare how many files, functions, variables, and lines of code are generated every time you change the MATLAB algorithm.
- Determine a target platform and allocation of RAM to the stack, based on the size of global variables plus the estimated stack size.
- Determine possible performance slow points, such as the largest global variables or the most costly call path in terms of stack usage.
- View the cyclomatic complexity of a function, which counts the number of linearly independent paths through a function.
- View the function call tree.
- Determine the longest call path to estimate the worst-case execution timing.
- View how target functions, provided by the selected code replacement library, are used in the generated code.

For more information, see [Generate a Static Code Metrics Report for MATLAB Code and Static Code Metrics](#).

## Model Architecture and Design

### **AUTOSAR user interface and round trip ARXML file import and export improvements**

#### **Improved graphical user interfaces for AUTOSAR configuration**

Embedded Coder software provides graphical user interfaces that allow you to add AUTOSAR elements to a Simulink model and map model components and interfaces to AUTOSAR components and interfaces. R2013a provides several improvements to the graphical user interfaces for AUTOSAR configuration:

- The Configure AUTOSAR Interface dialog box now provides separate **Simulink-AUTOSAR Mapping** and **AUTOSAR Properties** Explorers, which clearly distinguish mapping and editing activities.
- In both the Mapping and Properties Explorers:
  - Parameters that previously required text entry now offer selectable values or attributes.
  - Displays are more scalable (accommodating more elements) with fewer refresh issues.
  - Graphical layout reflects logical relationships between entities.
  - Filtering enhances element selection and modification.
- The Properties Explorer provides intuitive double-click and add/remove operations for configuring AUTOSAR ports, interfaces, data elements, runnables, and events.
- New check and synchronization icons provide single-click access to AUTOSAR configuration validation and Simulink model synchronization.
- A new AUTOSAR Component Builder dialog box allows you to interactively create a customized AUTOSAR component.

To explore the Configure AUTOSAR Interface dialog box, open a model that is already configured for AUTOSAR (such as the example model `rtwdemo_autosar_counter`). Select **Code > C/C++ Code > Configure Model as AUTOSAR Component** to open the dialog box. From there, you can select either the **Simulink-AUTOSAR Mapping** Explorer or the **AUTOSAR Properties** Explorer.

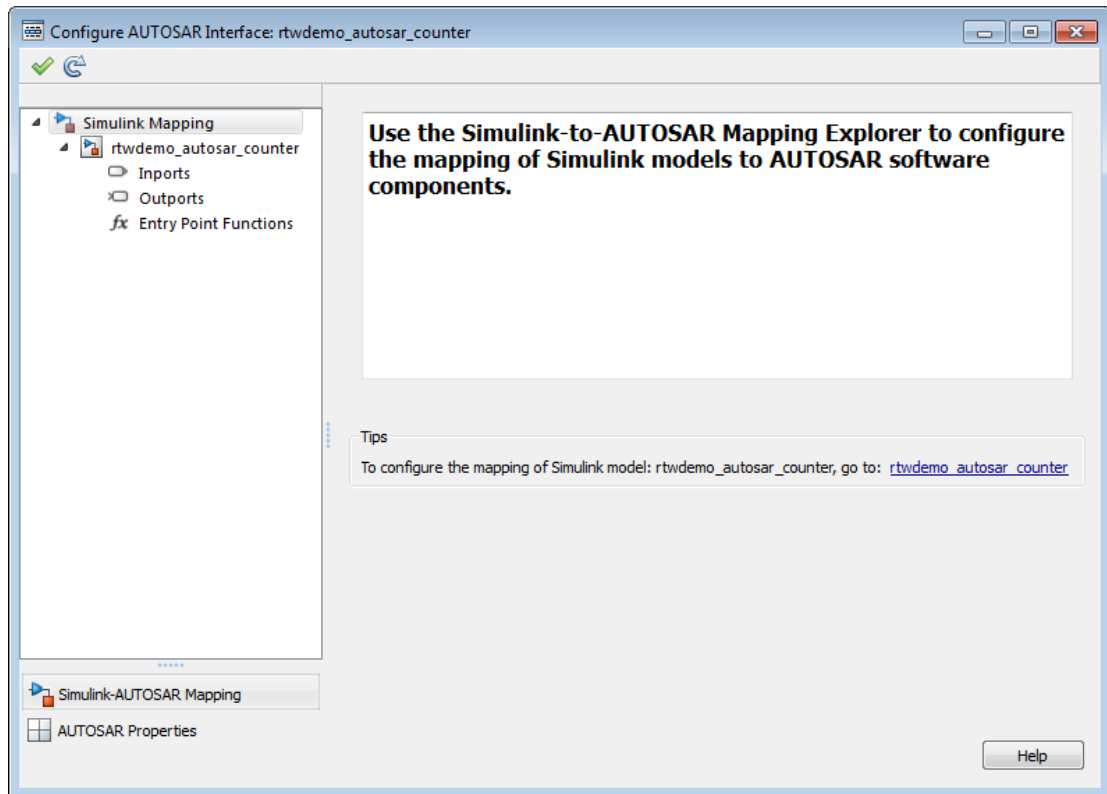

To explore the AUTOSAR Component Builder dialog box, open a model that is not already configured for AUTOSAR (such as the example model `rtwdemo_counter`). Select the AUTOSAR target (`autosar.tlc`) for the model, and then select **Code > C/C++ Code > Configure Model as AUTOSAR Component**. This action opens a dialog box that allows you to select between creating a default AUTOSAR component or interactively creating an AUTOSAR component. To open the AUTOSAR Component Builder dialog box, click **Create Component Interactively**.

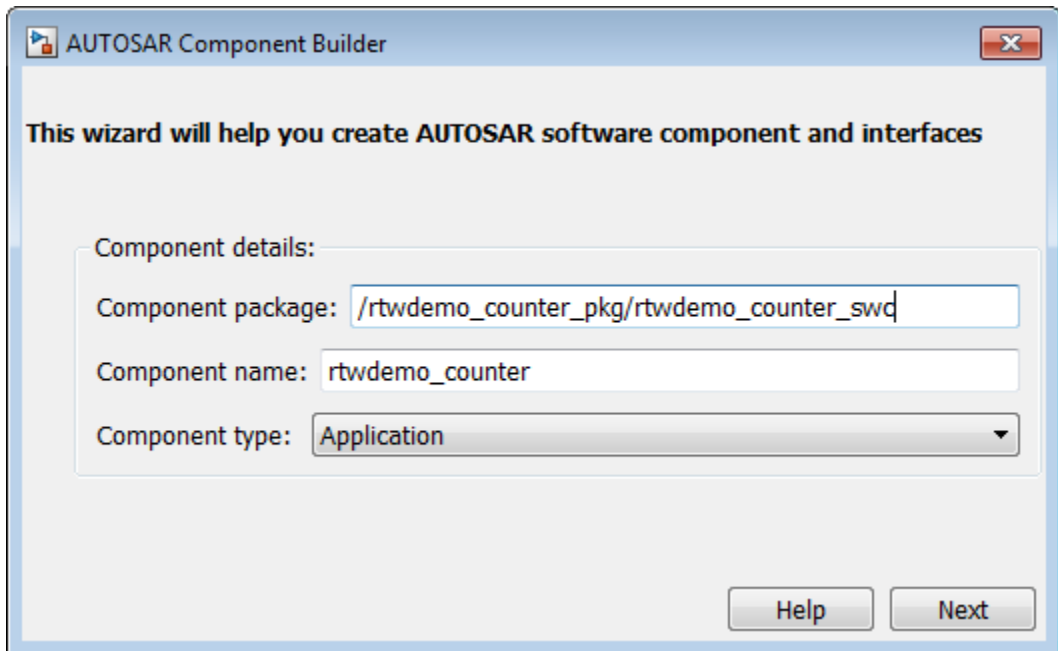

### Round-trip preservation of AUTOSAR elements and UUIDs

To help support the round trip of AUTOSAR elements between an AUTOSAR authoring tool (AAT) and the Simulink model-based design environment, Embedded Coder now preserves AUTOSAR elements and their UUIDs across arxml import and export, as follows:

- When arxml files created by an AAT are imported into a Simulink model, AUTOSAR element information is preserved, including UUIDs (for Identifiables), properties, and reference packages.
- When arxml files are exported from a Simulink model, the elements are generated back into arxml with their UUIDs and other information preserved.

As a result, the arxml files exported from Simulink can more easily be merged back into the AAT environment. Existing elements retain their UUIDs, while new elements created in Simulink get new UUIDs.



## **Code generation for variable-size scalar signals**

Previously, a model that used a variable-size scalar signal (width equals 1) would cause an error during a model update. This limitation has been removed and the model now simulates and generates code for a variable-size scalar signal.

## Data, Function, and File Definition

### Shortened system-generated identifier names

In R2013a, you have the option to shorten the system-generated identifier names to allow more space for user names. This option also provides a more predictable and consistent naming system that uses camel case, no underscores or plurals, and consistent abbreviations for both a type and a variable.

To use the new names, open the Configuration Parameters dialog box, and on the **Code Generation > Symbols** pane, set the **System-generated identifiers** parameter to Shortened. When you open a new model in R2013a, the default setting for **System-generated identifiers** is set to Shortened. When you open an existing model in R2013a, **System-generated identifiers** is set as Classic. With this setting, the system-generated identifiers use the names from previous releases.

For more information, see System-generated identifiers and Customize Generated Identifier Naming Rules.

### Improved data initialization with custom storage classes

Previously, Embedded Coder generated initialization code for these two cases, even though the **DataInitialization** parameter was set to None or Static.

- 1 Initial output of an Enabled Subsystem configured to reset when it is enabled.
- 2 Fixed-point data with bias, which cannot have zero ground value

Now, Embedded Coder will not generate dynamic initialization code for data that uses a custom storage class whose **DataInitialization** parameter is set to None or Static.

### Default specification for global types

Previously, on the Configuration Parameters **Symbol** pane, the default for **Global types** was  $\$N\$R\$M$ . In R2013a, for new models, the default for **Global types** is  $\$N\$R\$M\_T$ . For existing models opened in R2013a, **Global types** does not change.

### Subsystem block parameter Function packaging option renamed

In the Subsystem block parameter dialog box, on the **Code Generation** tab, the Function packaging option **Function** is renamed to **Nonreusable function**.

## Code Generation

### Model Advisor checks for code generation

The Model Advisor **By Product** folder contains the following checks to replace **Identify questionable blocks within the specified system**:

- Check for blocks not supported by code generation
- Check for blocks not recommended for C/C++ production code deployment

To display the **By Product** folder, in the Model Advisor window select **Settings > Preferences**. In the Model Advisor Preferences dialog box, select **Show By Product Folder**.

# Deployment

## Concurrent execution API to target embedded multicore platforms

### Semaphore and mutex code replacement for multicore target environments

Embedded Coder software now provides Simulink code replacement support for the following semaphore and mutex operations.

Mutex Destroy

Mutex Init

Mutex Lock

Mutex Unlock

Semaphore Destroy

Semaphore Init

Semaphore Post

Semaphore Wait

Semaphore and mutex code replacement is supported for:

- Simulink code generation for data transfer between tasks
- Code generation targets

Semaphore and mutex code replacement is not supported for:

- Stateflow charts, MATLAB Function blocks, and MATLAB functions
- Simulation targets

For more information, see [Map Semaphore or Mutex Operations to Target-Specific Implementations](#).

### Hardware timer function replacement

You can create a hardware-specific timer object for SIL and PIL simulations with your hardware target. See *Specification of hardware timer through the Code Replacement Tool* in “Code execution profiling improvements” on page 10-20.

## Hardware configuration relocation from Target Preferences block to Configuration Parameters dialog box

The contents of the Target Preferences block have been relocated to the new **Target Hardware Resources** tab on the Coder Target pane in the Configuration Parameters dialog box.

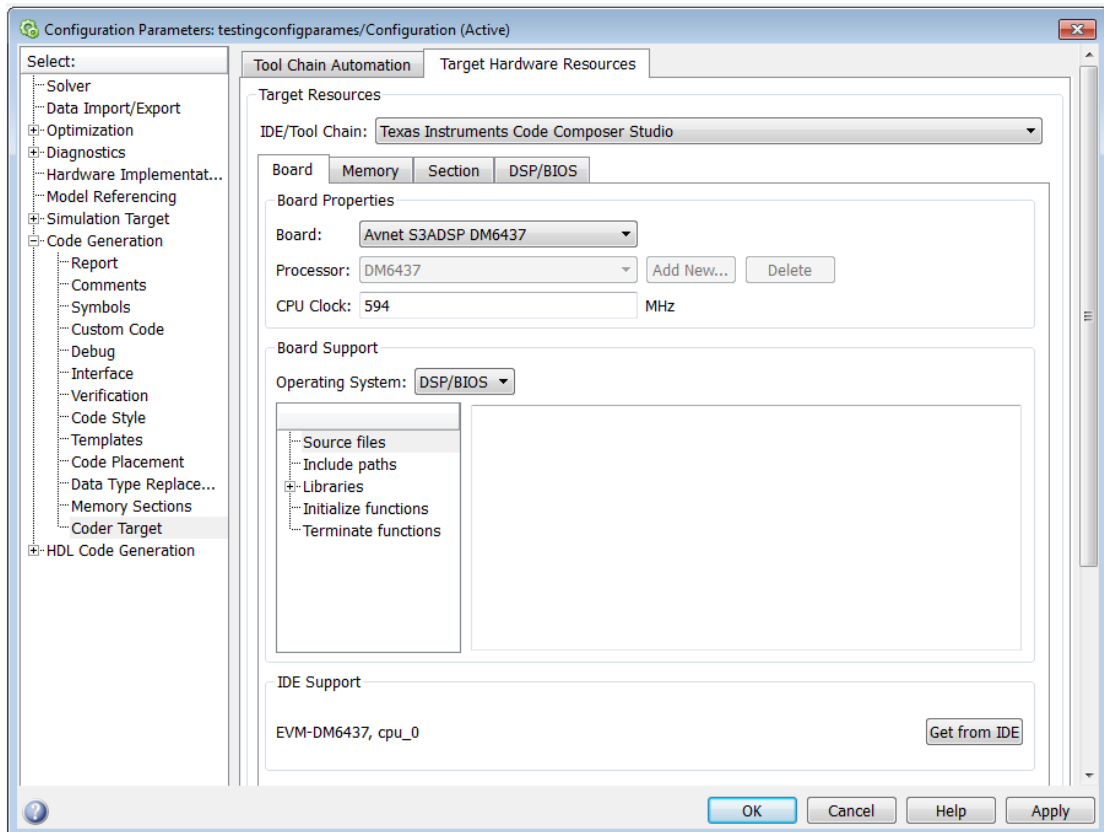

The Target Preferences block has been removed from the Embedded Targets block library.

If you open a model that contains a Target Preferences block, a warning instructs you that the block is optional and can be removed from your model.

Opening the Target Preferences block automatically displays the **Target Hardware Resources** tab.

For instructions on how to use **Target Hardware Resources** to build and run a model on target hardware, see Model Setup.

For information about specific parameters and settings, see Code Generation: Coder Target Pane.

## Downloadable support and blocks for Analog Devices DSPs

If you have an Embedded Coder license, you can install support for Analog Devices VisualDSP++ IDE and DSPs as described in Install Support for Analog Devices DSPs. Support for Analog Devices VisualDSP++ IDE and DSPs includes the same capabilities that were previously available.

Use the “Embedded Coder Support Package for Analog Devices DSPs” block library to manage peripherals, scheduling, and memory on Blackfin<sup>®</sup>, SHARC<sup>®</sup>, and TigerSHARC<sup>®</sup> DSPs.

To get these capabilities, in a MATLAB Command Window, enter `supportPackageInstaller`. Then, use Support Package Installer to install the support package for Analog Devices DSPs. For more information, see the Working with Analog Devices VisualDSP++ IDE topic.

After installing the support package, you can open the block library. In the MATLAB Command Window, enter `adivdsp1ib`. The “Embedded Coder Support Package for Analog Devices DSPs” block library is also available in the Simulink Library Browser.

## Compatibility Considerations

Previously, installing Embedded Coder software automatically installed support and blocks for Analog Devices DSPs. Effective this release, you must use Support Package Installer to install support before using Embedded Coder with Analog Devices DSPs.

## Texas Instruments C2000 Clocking Options

In the Configuration Parameters dialog box, on the **Peripherals** tab, the new **Clocking** options help you to configure different timers that you use in the processor peripherals.

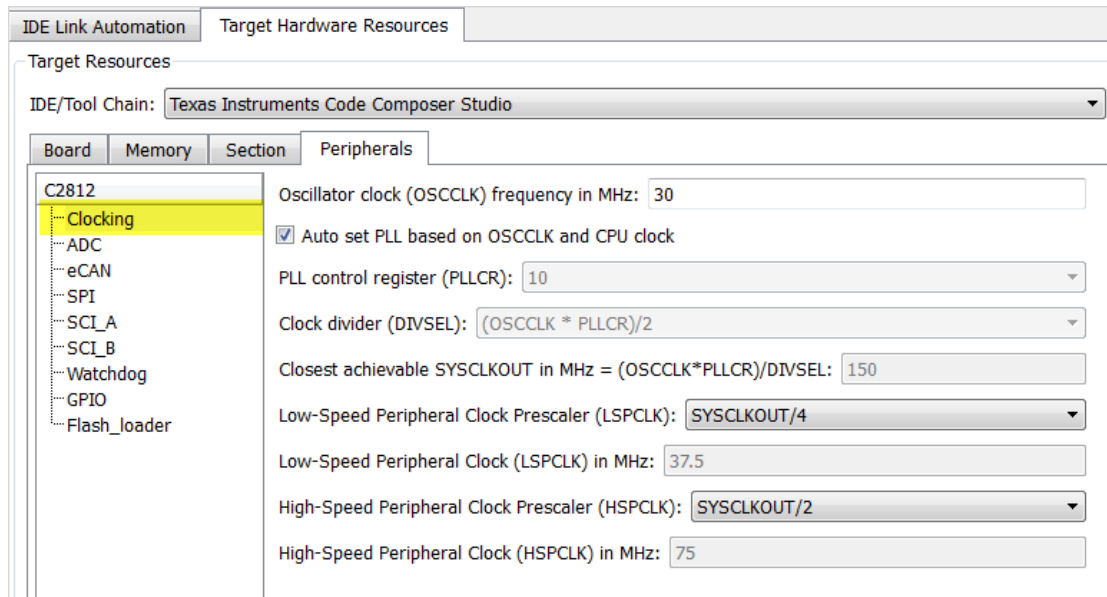

- The high-speed and low-speed clock settings help you to configure the baud rates for peripherals, such as SCI and SPI.
- You can specify the oscillator clock frequency used in the processor to set the system clock out parameter for the device. Based on the system clock out value, you can get feedback on the baud rate and the time settings.
- Automatic setting of the prescalers is done based on user-defined baud rate for peripherals, such as SCI and SPI.
- Based on the settings that you make in the Clocking peripheral, you can see the timing-related feedback for the peripherals, such as eCAN, I2C, ADC, and Watchdog.
- The parameter relationship is shown at the prompts in some of the peripherals. For example, in eCAN, at the baud rate parameter, you can see, CAN Module Clock/BRP/(TSEG1+TSEG2+1) in bits/sec.

## Support for Texas Instruments C2802x and Texas Instruments C2803x variants

You can now run models on the following variants of TI C2802x and TI C2803x processors:

- F28030
- F28031
- F28032
- F28033\_cpu
- F28034
- F280200
- F28020
- F28021
- F28022
- F28026

You can use the following block libraries with these variants:

- C2802x (c2802xlib)
- C2803x (c2803xlib)

## Downloadable support and blocks for Xilinx Zynq-7000 platform

Use the Embedded Coder Support Package for Xilinx Zynq-7000 Platform to automatically build (makefile-based), download, and run an executable on the *Xilinx Zynq-7000 SoC ZC702 Evaluation Kit*. The executable runs in the Linux environment on the ARM Cortex-A9 processor on the *ZC702 Evaluation Kit*.

Use blocks from the Embedded Coder Support Package for Xilinx Zynq-7000 Platform block library:

- The UDP Receive and UDP Send blocks enable communication with networked devices using an Ethernet port.
- The Linux Task block spawns a task function as separate Linux thread.

To download and install this feature, click **Add-Ons > Get Hardware Support Packages** on the MATLAB toolstrip. Then, use Support Package Installer to install the Embedded Coder Support Package for Xilinx Zynq-7000 Platform. For more information, see the Working with the Xilinx Zynq-7000 Platform topic.

## Support ending for Eclipse IDE in a future release

Support for the Eclipse IDE will end in a future release of the Embedded Coder and Simulink Coder products.



## Support ending for remoteBuild method in a future release

Support for the remoteBuild method will end in a future release of the Embedded Coder products.

## Compatibility Considerations

Use Support Package Installer to install the support package for BeagleBoard hardware, as described in [Install Support for BeagleBoard Hardware](#). Then, use the Simulink capability called “Run on Target Hardware” instead of `remoteBuild` to build and run models on BeagleBoard hardware.

For more information about using Run on Target Hardware with BeagleBoard, see the [BeagleBoard](#) topic.

## Performance

### Optimized function arguments for nonreusable subsystems

For nonreusable subsystems, you can specify the function interface in the generated code to use arguments. This specification reduces global RAM. It might reduce code size and improve execution speed, and allow the code generator to apply additional optimizations.

To optimize the function interface for a subsystem, in the Subsystem Block Parameter dialog box, on the **Code Generation** tab, set the **Function packaging** parameter to **Nonreusable function** (previously, named **Function**). The **Function packaging** parameter enables the **Function interface** parameter. Set the **Function interface** parameter to **Allow arguments**.

For more information, see [Function interface and Reduce Global Variables in Nonreusable Subsystem Functions](#).

### Reduced data copies for tunable parameter expressions

Previously, in the generated code, tunable parameter expressions were copied to a temporary variable. In R2013a, the generated code removes this temporary variable. The removal of this unnecessary data copy improves execution speed, reduces code size and global RAM, and allows for additional code optimizations.

For example, for a tunable parameter, **b**, used in a Constant block, the code was:

```
/*Constant: '<Root>/Constant'*/  
for (i=0; i<9; i++){  
    tunable_expr_copy_B.Constant[i] = Param.b[i];  
}  
/*End of Constant: '<Root>/Constant'*/  
  
/*S-Function(MySFun2D): '<Root>/S-Function Builder'*/  
MySFun2D_Outputs_wrapper(tunable_expr_copy_B.Constant);
```

Now, the generated code is:

```
/*S-Function(MySFun2D): '<Root>/S-Function Builder'*/  
MySFun2D_Outputs_wrapper(Param.b);
```

## **Removal of unused global variables**

In R2013a, unused global variables generated from a For Each subsystem and bitfields are removed. This code generation enhancement reduces global RAM.

## Verification

### Debugging during SIL simulations

If you notice differences between the results of a Normal mode simulation and a SIL mode simulation, you can select the **Configuration Parameters > Verification > Enable source-level debugging for SIL** check box and rerun the SIL simulation. Then, from the Microsoft Visual Studio IDE, you can insert break points in the generated source code and step through the code during the SIL simulation. Observing code behavior in this way can help you to understand the differences in results. For example, when you are trying to integrate legacy code with generated code and the integration does not run as expected.

For more information, see [Debugging During SIL Simulations](#).

### Simulation of multiple SIL Model blocks in a top model

If you have a top model containing Model blocks, you can simulate the model with multiple Model blocks in SIL mode. Previously, you could not simulate the top model with more than one Model block in SIL mode. To verify the different Model blocks, you had to run multiple simulations. Before each simulation, you had to specify the SIL mode for one Model block. The removal of this limitation reduces verification time.

If you specify code coverage or code execution profiling, the software does not support this feature.

### API for testing `rtiostream` communications

To run PIL or External mode simulations with custom hardware, you write your own `rtiostream` implementations.

R2013a provides a test suite to debug and prove the behavior of custom `rtiostream` interface implementations.

This new API has the following advantages:

- Reduces time for integrating custom hardware that does not have built-in `rtiostream` support.

- Reduces time for testing custom `rtiostream` drivers.
- Helps analyze the performance of custom `rtiostream` drivers.

This test suite has two parts. One part of the test suite runs on the target.

To launch this part, compile and link the following files, which are in `matlabroot/toolbox/coder/rtiostream/src/rtiostreamtest`.

- `rtiostreamtest.c`
- `rtiostreamtest.h`
- `rtiostream.h`
- `rtiostream` implementation under investigation (e.g., `rtiostream_tcpip.c`)
- `main.c`

To run the second part of the test suite, invoke `rtiostreamtest`. The syntax is as follows:

```
function rtiostreamtest(connection,param1,param2)
```

- `connection` is a string indicating the communication method. It can have values `'tcp'` or `'serial'`.
- `param1` and `param2` have different values depending on the value of `connection`.
  - If `connection` is `'tcp'`: `param1`, `param2` are hostname and port, respectively.
  - If `connection` is `'serial'`: `param1`, `param2` are COM port and baud rate, respectively.

For example, you can run the second part of the test suite as follows:

```
function rtiostreamtest('tcp','localhost','2345')
```

## SIL and PIL support for targets with multicore processors

R2013a allows you to run SIL and PIL simulations of models that are configured for targets with multicore processors:

- You can run SIL and PIL simulations of **single-rate** component models in a concurrent execution model hierarchy, without modifying models or regenerating code.

- Previously, the configuration parameters, `TargetOS` and `ConcurrentTasks`, had to be the same across a model hierarchy. This restriction has been removed.

## Additional code annotation for justifying Polyspace checks

New Polyspace code annotations have been added to justify occurrences of `<<` and `+` inside fixed-point multiplication helper functions.

For more information, see [Code Annotation for Justifying Polyspace Checks](#).

## Code execution profiling improvements

### Comprehensive measurement and reporting of function execution times

R2013a provides comprehensive measurement and reporting of function execution times:

- The software measures execution times for initialization, shared utility and math library functions.
- The software inserts instrumentation probes around a function call site so that the measured time includes the time taken to call the function. Previously, the software inserted instrumentation probes inside the function. As a result, the measured time represented the execution time for only the function body.
- You can specify the time unit and numeric format for the time measurements in the code execution profiling report. Previously, the software reported execution times only in clock ticks. For information about the new default specifications for time unit and numeric format, see report.
- The code execution profiling report contains hyperlinks to function call sites in the SIL/PIL test harness. Previously, the report provided hyperlinks to only source code files generated from the model.

For more information, see [Code Execution Profiling](#).

### Viewing and comparing execution time plots with the Simulation Data Inspector

You can use the Simulation Data Inspector to view and compare plots of function execution times. If you select **All measurement and analysis data** from the **Configuration Parameters > Code Generation > Verification > Save options** drop-down list, the software automatically imports SIL simulation results into the

Simulation Data Inspector. This feature allows you to plot execution times and manage and compare plots from various simulations.

For more information, see [Configure Code Execution Profiling and View and Compare Code Execution Times](#).

### **Specification of hardware timer through the Code Replacement Tool**

In SIL and PIL simulations, if your hardware target does not have built-in timer support, you must create a timer object that provides details of the hardware-specific timer and associated source files. In R2013a, you can specify this hardware-specific timer using either the graphical user interface of the Code Replacement Tool or the corresponding command line API. The software stores the timer information as a Code Replacement Library (CRL) table.

Previously, you could specify the timer using the MATLAB function `coder.profile.Timer`. However, support for this function will cease in a future release.

For more information, see [Specify Hardware Timer](#).

### **Code-to-model traceability links for reusable subsystems in libraries**

Code-to-model traceability links are now available in the generated code for a reusable library subsystem. Code-to-model traceability links for a reusable library subsystem appear in the comments of the generated code in the code generation report. The traceability link is the name of the library.

File: [RLS\\_HylfoiOq.c](#)

```

11
12 #include "RLS_HylfoiOq.h"
13
14 /* Output and update for atomic system: 'SS1' ('ssreuselib:1') */
15 void RLS_HylfoiOq(const real_T *rtu_In1, const real_T *rtu_In2, real_T *rty_Out1,
16                  const real_T rtp_y[11], const real_T rtp_x[11])
17 {
18     /* Lookup_n-D: 'Lookup Table' ('ssreuselib:4') incorporates:
19      * Sum: 'Sum' ('ssreuselib:5')
20      */
21     *rty_Out1 = looki_binlxy(*rtu_In1 + *rtu_In2, rtp_x, rtp_y, 10U);
22 }

```

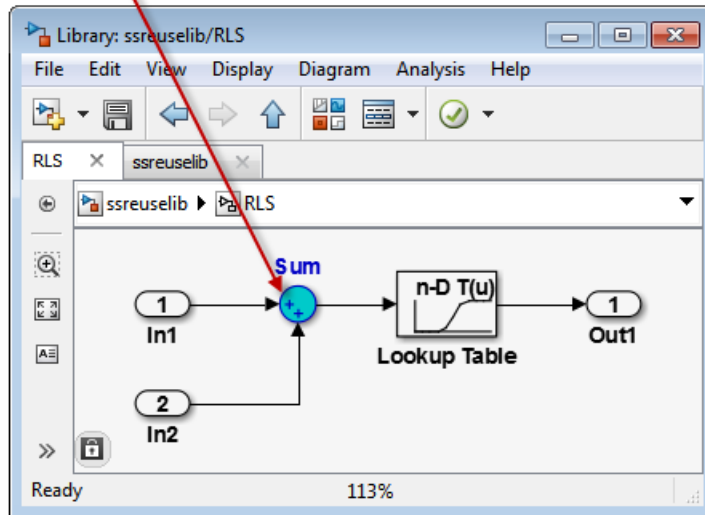

To include traceability links in the generated code comments, see Traceability in Code Generation Report.



## Check bug reports for issues and fixes

Software is inherently complex and is not free of errors. The output of a code generator might contain bugs, some of which are not detected by a compiler. MathWorks reports critical known bugs brought to its attention on its Bug Report system at [www.mathworks.com/support/bugreports/](http://www.mathworks.com/support/bugreports/). Use the Saved Searches and Watched Bugs tool with the search phrase "Incorrect Code Generation" to obtain a report of known bugs that produce code that might compile and execute, but still produce wrong answers.

The bug reports are an integral part of the documentation for each release. Examine periodically all bug reports for a release, as such reports may identify inconsistencies between the actual behavior of a release you are using and the behavior described in this documentation.

In addition to reviewing bug reports, you should implement a verification and validation strategy to identify potential bugs in your design, code, and tools.



# R2012b

**Version: 6.3**

**New Features**

**Bug Fixes**

**Compatibility Considerations**

## Cyclomatic complexity measurement in static code metrics report

In R2012b, the static code metrics report includes a cyclomatic complexity measurement for each function. You can view the measurement in the **Complexity** column of the Function Information table. For more information, see [Analyze Static Code Metrics](#).

## Custom code substitution for MATLAB functions using code replacement libraries

The `coder.replace` function provides the ability to replace a specified MATLAB function with a code replacement library (CRL) function in the generated code. You can use `coder.replace` both in MATLAB code from which you want to generate C code using MATLAB Coder and in MATLAB code in a MATLAB Function block. For more information, see [coder.replace, Replace MATLAB Function with Custom Code](#), and [Replace MATLAB Function Block Code with Custom Code](#).

In addition, you can use the code replacement tool to create and register code replacement tables. These tables provide the basis for replacing default math functions and operators in your generated code with target-specific code. The ability to control function and operator replacements potentially allows you to optimize target speed and memory and better integrate generated code with external and legacy code.

Access the code replacement tool using one of these methods:

- At the MATLAB command line, enter:  

```
crtool
```
- On the MATLAB Coder **Project Settings** dialog box **Hardware** tab, click the **Custom** link.

For more information, see [Create Code Replacement Table for a Sample MATLAB Coder Project](#).

## SIL and PIL support for signal logging, encapsulated C++, and AUTOSAR calibration parameters

Beginning in R2012b, Embedded Coder software supports using Simulink signal logging, encapsulated C++ code, and AUTOSAR calibration parameters in SIL and PIL mode simulations.

## Signal logging for SIL and PIL simulations

In R2012b, Simulink signal logging is extended to the SIL and PIL simulation modes. This allows you to:

- Collect signal logging outputs (e.g., `logout`) during SIL and PIL simulations.
- Log the internal signals and the root-level outputs of a SIL or PIL component.
- Manage the SIL and PIL signal logging settings using the Simulink Signal Logging Selector.
- More easily compare logged signals between normal, SIL, and PIL simulations, for example, using Simulation Data Inspector.

Signal logging is supported with the following forms of SIL and PIL simulation:

- Top-model SIL or PIL
- Model block (referenced model) SIL or PIL

SIL or PIL signal logging requires the following model configuration settings:

- On the **Data Import/Export** pane of the Configuration Parameters dialog box, set **Signal logging format** to **Dataset**.
- On the **Code Generation > Interface** pane of the Configuration Parameters dialog box, set **Interface** to **C API**.

## Use SIL and PIL simulations to verify encapsulated C++ code

Previously, you could use SIL and PIL simulations to verify code generated with the model configuration **Language** setting **C** or **C++**. Beginning with R2012b, you can also use the **Language** setting **C++ (Encapsulated)**.

Encapsulated C++ code is supported with the following forms of SIL and PIL simulation:

- SIL or PIL block
- Top-model SIL or PIL
- Model block (referenced model) SIL or PIL

## Improved SIL and PIL verification for AUTOSAR-compliant code

The following forms of SIL and PIL simulation support AUTOSAR calibration parameters in generated code:

- SIL or PIL block

- Top-model SIL or PIL

You can use the calibration parameter custom storage classes `CalPrm` and `InternalCalPrm` to reference data.

## AUTOSAR 4.0 nonscalar data support

R2012b extends Embedded Coder support for using nonscalar data in models from which AUTOSAR 4.0 compatible code is generated. Previously, you could use nonscalar data associated with port elements, calibration parameters, and per-instance memory. Beginning in R2012b, you also can use nonscalar inter-runnable variables (IRVs) in models configured for AUTOSAR.

For information about other AUTOSAR-related enhancements and changes, see “AUTOSAR software component import and export enhancements” on page 11-8.

## Code annotation for justifying Polyspace checks

You can apply Polyspace verification to generated code using the Polyspace Model Link™ SL product. The software detects run-time errors in the generated code. It also helps you to locate and fix model faults.

Because of the way Embedded Coder implements certain operations, Polyspace might indicate potential overflows for operators or operations that are actually legitimate.

Previously, you manually justified the associated orange checks in the Polyspace verification environment.

Now, if you select the new check box, **Configuration Parameters > Code Generation > Comments > Auto generate comments > Operator annotations**, the Embedded Coder software annotates the generated code with comments for Polyspace. When you run a Polyspace verification, the Polyspace software uses the comments to justify overflows associated with legitimate operations and assigns the `Not a Defect` classification to the corresponding checks.

For more information, see [Code Annotation for Justifying Polyspace Checks](#).

## Texas Instruments Code Composer Studio IDE 5.1 support

This release adds support for version 5.1 of the Texas Instruments Code Composer Studio IDE (CCS) to existing support for CCS versions 3.3 and 4.1.

Support for CCS version 5.1 includes the following capabilities:

- Automatic creation of makefile projects
- Support for DSP/BIOS™ version 5.41.xx
- Support for C6000 Compiler version 7.3.x

For more information, see *Working with Texas Instruments Code Composer Studio IDE*.

## External mode support for ERT targets with static main

Previously, Embedded Coder software supported External mode for ERT targets only if the associated main program was automatically generated by the model build process. Beginning in R2012b, the software also supports External mode for ERT targets with a static main program. Specifically, the static main file `matlabroot/rtw/c/src/common/rt_main.c` has been enhanced to support External mode.

If you have authored a custom ERT-based target, you can support External mode with your custom main program by updating your main program, using the code in `rt_main.c` as an example.

## Downloadable support for Green Hills MULTI

If you have an Embedded Coder license, you can install support for Green Hills MULTI IDE (MULTI) as described in *Install Support for Green Hills MULTI IDE*. Support for MULTI includes the same capabilities that were previously available.

After installing support for MULTI, you can use the “Target for Use with Green Hills MULTI IDE” block library, located in the Simulink Library Browser. You can open this block library by entering `idelinklib_ghsmulti` in the MATLAB Command Window.

The block library contains blocks for:

- Analog Devices Blackfin processors
  - Memory Allocate
  - Memory Copy
  - Blackfin Hardware Interrupt
  - Idle Task
- Freescale MPC55xx and MPC74xx processors

- Memory Allocate
- Memory Copy
- Idle Task
- MPC5500 Interrupt
- MPC7400 Hardware Interrupt

## Compatibility Considerations

Previously, Embedded Coder software included support for MULTI. Now, use Target Installer to install support before using Embedded Coder with MULTI.

## Support for Texas Instruments C2806x processors

This release adds support for Texas Instruments C2806x processors to Embedded Coder.

This support adds the C2806x (c2806xlib) block library to the Simulink Library Browser. The C2806x block library includes the following blocks:

- C2802x/C2803x/C2806x ADC
- C2802x/C2803x/C2806x AnalogIO Input
- C2802x/C2803x/C2806x AnalogIO Output
- C28x CAN Calibration Protocol
- C2802x/C2803x/C2806x COMP
- C280x/C2802x/C2803x/C2806x/C28x3x/c2834x GPIO Digital Input
- C280x/C2802x/C2803x/C2806x/C28x3x/c2834x GPIO Digital Output
- C28x I2C Receive
- C28x I2C Transmit
- C28x SCI Receive
- C28x SCI Transmit
- C28x SPI Receive
- C28x SPI Transmit
- C28x Software Interrupt Trigger
- C28x Watchdog
- C28x eCAN Receive



- C28x eCAN Transmit
- C28x eCAP
- C280x/C2802x/C2803x/C2806x/C28x3x/c2834x ePWM
- C28x eQEP

For more information, see C2806x (c2806xlib).

## Performance enhancement of Simulink data objects

In R2012b, Simulink can create and load subclasses of Simulink data classes more efficiently. To take advantage of this enhancement, use the `setupCoderInfo` method to configure the `CoderInfo` object of your class. The `setupCoderInfo` method is called once during object construction.

Consider the example of the `ECoderDemos.Parameter` class. Previously, this class was defined as follows. Notice how the `CoderInfo` object is configured in the class constructor.

```
classdef Parameter < Simulink.Parameter
% ECoderDemos.Parameter Class definition.

    methods
        function h = Parameter(optionalValue)
            % Use custom storage classes from this package
            useLocalCustomStorageClasses(h, 'ECoderDemos');

            % Set up object to use custom storage classes by default
            h.CoderInfo.StorageClass = 'Custom';

            % Initialize Value property
            switch nargin
                case 0,
                    % No action
                case 1,
                    h.Value = optionalValue;
            end
        end
    end % methods
end % classdef
```

In this release, the `ECoderDemos.Parameter` class is defined as follows. Notice the use of the `setupCoderInfo` method to configure the `CoderInfo` object. The rest of the constructor method is unchanged.

---

**Note:** You can access this class definition at `matlabroot/toolbox/rtw/targets/ecoder/ecoderdemos/dataclasses - /+ECoderDemos/@Parameter/Parameter.m`.

---

```
classdef Parameter < Simulink.Parameter
% ECoderDemos.Parameter Class definition

    methods
        function setupCoderInfo(h)
            % Use custom storage classes from this package
            useLocalCustomStorageClasses(h, 'ECoderDemos');

            % Set up object to use custom storage classes by default
            h.CoderInfo.StorageClass = 'Custom';
        end

        function h = Parameter(optionalValue)
            % Initialize Value property
            switch nargin
                case 0,
                    % No action
                case 1,
                    h.Value = optionalValue;
            end
        end
    end % methods
end % classdef
```

## AUTOSAR software component import and export enhancements

R2012b adds AUTOSAR workflow improvements, including import validation and faster import and export of arxml files. See also “AUTOSAR 4.0 nonscalar data support” on page 11-4.

### Import validation

Beginning in R2012b, the AUTOSAR software component importer validates the XML in the imported arxml files. If XML validation fails for a file, the importer displays errors. For example:

```
Error
The IsService attribute is undefined for interface /mtest_pkg/mtest_if/In1
in file hArxmlFileErrorMissingIsService_SR_3p2.arxml:48.
Specify the IsService attribute to be either true or false
```

In this example message, the file name is a hyperlink, and you can click the hyperlink to see the location of the error in the arxml file.

### Faster import and export of arxml files

Beginning in R2012b, Embedded Coder software provides up to 20 times faster import and export of AUTOSAR software component descriptions.

### Explicit access mode for AUTOSAR Sender and Receiver ports

Previously, the AUTOSAR software component importer did not support explicit data access modes for AUTOSAR component Sender and Receiver ports. It issued a warning for an explicit data access mode and set the port data access mode to implicit. Beginning in R2012b, the importer analyzes the AUTOSAR software component to determine whether the data access mode for a port is implicit or explicit. The importer honors an explicit access mode setting. However, if conflicting data access modes are detected, the importer issues a warning and sets the data access mode to implicit.

### Import port-based calibration parameters

The AUTOSAR software component importer has been enhanced to import any port-based calibration parameters referenced in the AUTOSAR software component. For each imported parameter, the importer creates a data object in the MATLAB base workspace.

### Highlight virtual blocks in model Web view of code generation report

In the model Web view of the code generation report, when tracing between the model and the code, if you click a virtual block and no code is highlighted in the generated code pane, the virtual block is highlighted yellow.

## Code Execution Profiling Improvements

### Updated Code Execution Profiling API

The existing code execution profiling APIs, `rtw.pil.ExecutionProfile` and `rtw.pil.ExecutionProfileSection`, have been replaced with `coder.profile.ExecutionTime` and `coder.profile.ExecutionTimeSection` respectively.

## Compatibility Considerations

The old class names and methods forward to the corresponding new class names and methods. A warning is not issued. The old method names are hidden and no longer documented.

### New Properties and Methods

The following new methods and properties have been added:

Interface	Method or Property
<code>coder.profile.Timer</code>	<code>coder.profile.Timer</code>

Interface	Method or Property
coder.profile.ExecutionTime	display
	Sections
	TimerTicksPerSecond
	report
coder.profile.ExecutionTimeSection	ExecutionTimeInTicks
	MaximumExecutionTimeCallNum
	MaximumExecutionTimeInTicks
	MaximumSelfTimeCallNum
	MaximumSelfTimeInTicks
	Name
	Number
	NumCalls
	SampleOffset
	SamplePeriod
	SelfTimeInTicks
	TotalExecutionTimeInTicks
	TotalSelfTimeInTicks

### Functionality Being Removed or Changed

The following functionality is being removed or changed:

Functionality	What Happens When You Use This Functionality?	Use This Instead	Compatibility Considerations
rtw.connectivity.Timer	Call is forwarded to coder.profile.Timer without warning message.	coder.profile.Timer	All methods are the same as rtw.connectivity.Timer.
rtw.pil.ExecutionProfile-.display	Call is forwarded to coder.profile.ExecutionTime.display without warning message.	display	None

Functionality	What Happens When You Use This Functionality?	Use This Instead	Compatibility Considerations
<code>rtw.pil.ExecutionProfile-</code>	Call is forwarded to <code>coder.profile.ExecutionTime.report</code> without warning message.	<code>report</code>	None
<code>rtw.pil.ExecutionProfile-</code> <code>rtw.pil.ExecutionProfile-</code>	Call is forwarded to <code>coder.profile.ExecutionTime.Sections</code> without warning message.	<code>Sections</code>	Uses property syntax
<code>rtw.pil.ExecutionProfile-</code> <code>rtw.pil.ExecutionProfile-</code>	Calls are forwarded to property <code>coder.profile.ExecutionTime.TimerTicksPerSecond</code> without warning message.	<code>TimerTicksPerSecond</code>	Uses property syntax
<code>rtw.pil.ExecutionProfileSection.getMaxTicks</code>	Call is forwarded to <code>coder.profile.ExecutionTimeSection.MaximumExecutionTimeInTicks</code> without warning message.	<code>MaximumExecutionTimeInTicks</code>	Uses property syntax
<code>rtw.pil.ExecutionProfileSection.getName</code>	Call is forwarded to <code>coder.profile.ExecutionTimeSection.Name</code> without warning message.	<code>Name</code>	Uses property syntax
<code>rtw.pil.ExecutionProfileSection.getNumCalls</code>	Call is forwarded to <code>coder.profile.ExecutionTimeSection.NumCalls</code> without warning message.	<code>NumCalls</code>	Uses property syntax
<code>rtw.pil.ExecutionProfile-</code>	Call is forwarded to <code>coder.profile.ExecutionTime.Number</code> without warning message.	<code>Number</code>	Uses property syntax

Functionality	What Happens When You Use This Functionality?	Use This Instead	Compatibility Considerations
<code>rtw.pil.ExecutionProfileSection.getTicks</code>	Call is forwarded to <code>coder.profile.ExecutionTimeSection.ExecutionTimeInTicks</code> without warning message.	<code>ExecutionTimeInTicks</code>	Uses property syntax
<code>rtw.pil.ExecutionProfile-</code>	Call is forwarded to the legacy <code>getTimes</code> function without warning message.	Calculate execution time in seconds by the formula $\text{ExecutionTimeInSecs} = \text{ExecutionTimeInTicks} / \text{TimerTicksPerSecond}$ .	No equivalent to <code>getTimes</code> in new interface.
<code>rtw.pil.ExecutionProfileSection.getTotalTicks</code>	Call is forwarded to <code>coder.profile.ExecutionTimeSection.TotalExecutionTimeInTicks</code> without warning message.	<code>TotalExecutionTimeInTicks</code>	Uses property syntax
<code>rtw.pil.ExecutionProfileSection.getSampleOffset</code>	Call is forwarded to <code>coder.profile.ExecutionTimeSection.SampleOffset</code> without warning message.	<code>SampleOffset</code>	Uses property syntax
<code>rtw.pil.ExecutionProfileSection.getSamplePeriod</code>	Call is forwarded to <code>coder.profile.ExecutionTimeSection.SamplePeriod</code> without warning message.	<code>SamplePeriod</code>	Uses property syntax
<code>rtw.pil.ExecutionProfileSection.getTotalSelfTicks</code>	Call is forwarded to <code>coder.profile.ExecutionTimeSection.TotalSelfTimeInTicks</code> without warning message.	<code>TotalSelfTimeInTicks</code>	Uses property syntax

### Code Execution Profiling Supports Single Object Output

Code execution profiling during a SIL or PIL simulation honors the **Save simulation output as a single object** setting.

If the **Measure task execution time** check box is selected in the **Verification** pane and the **Save simulation output as a single object** check box is selected in the **Data Import/Export** pane, then the **Workspace variable** defined in the **Verification** pane is saved in the single output object instead of in the base workspace.

## **Incremental Compilation with Changes in Code Coverage Settings**

If only code coverage settings have changed and the generated code is otherwise up to date, code is not regenerated. Instead, the existing up-to-date code is recompiled using the new code coverage settings.

## Check bug reports for issues and fixes

Software is inherently complex and is not free of errors. The output of a code generator might contain bugs, some of which are not detected by a compiler. MathWorks reports critical known bugs brought to its attention on its Bug Report system at [www.mathworks.com/support/bugreports/](http://www.mathworks.com/support/bugreports/). Use the Saved Searches and Watched Bugs tool with the search phrase "Incorrect Code Generation" to obtain a report of known bugs that produce code that might compile and execute, but still produce wrong answers.

The bug reports are an integral part of the documentation for each release. Examine periodically all bug reports for a release, as such reports may identify inconsistencies between the actual behavior of a release you are using and the behavior described in this documentation.

In addition to reviewing bug reports, you should implement a verification and validation strategy to identify potential bugs in your design, code, and tools.



# R2012a

**Version: 6.2**

**New Features**

**Bug Fixes**

**Compatibility Considerations**

## AUTOSAR Enhancements

### AUTOSAR Release 4.0

R2012a supports AUTOSAR Release 4.0 (version 4.0.2), which includes:

- Import and export of AUTOSAR R4.0 XML files
- Generation of AUTOSAR R4.0 code
- Support for *application* and *implementation* data types and *base* types. For more information, see Data Type Support for Release 4.0.
- Code replacement library (CRL) support for over 300 routines from the following AUTOSAR libraries:
  - Floating-Point Math (AUTOSAR\_SWS\_MFLLibrary)
  - Fixed-Point Math (AUTOSAR\_SWS\_MFXLibrary)

### Support for Schema 2.0 Removed

Support for AUTOSAR schema version 2.0 has been removed from R2012a. The software now supports the following schema versions:

- 4.0 (4.0.2)
- 3.2 (3.2.1)
- 3.1 (3.1.4) — Default
- 3.0 (3.0.2)
- 2.1 (XSD rev 0017)

## Code Efficiency Enhancements

### For Each Subsystem Loop Bound Passed by Value

The generated code of the For Each subsystem includes a loop bound that was previously passed by a pointer. In R2012a, the loop bound is passed by value which improves memory usage and execution speed.

For example, if you have a For Each subsystem with a **Function name**, `myFcnVectorized`, the generated code for the function prototype is:

```
void myFcnVectorized(int32_T NumIters, ...) {  
    for (ForEach_itr = 0;
```

```

    ForEach_itr < NumIters;
    ForEach_itr++) { ...

```

The argument `NumIters` is passed by value, instead of by pointer. The function is called as follows:

```
myFcnVectorized(3, ...
```

For more information, see [For Each Subsystem](#) in the Simulink documentation.

### Fully Inlined S-functions from Legacy Code Tool

The Legacy Code Tool now automatically generates fully inlined S-functions for legacy code. Previously, the generated code included an unnecessary data copy for the function-call input. In R2012a, these temporary variables are no longer generated. This enhancement reduces memory usage and improves execution speed, as well as enabling other optimizations and a consistent coding style.

For example, temporary variables, `tmp` and `tmp_0`, were used for the generated function-call input:

```

int32_T i;
real_T tmp[6];
real_T tmp_0[6];
for (i = 0; i < 6; i++) {
/* S-Function (rtwdemo_sfundarray_add): '<S1>/rtwdemo_sfundarray_add' */

array3d_add(rtb_Output1,tmp,tmp_0,1,2,3);

```

Now, the generated code is:

```

int32_T i;

/* S-Function (rtwdemo_sfundarray_add): '<S1>/rtwdemo_sfundarray_add' */

array3d_add(rtb_Output1, rtwdemo_lct_ndarray_ConstP.Constant_Value,
            rtwdemo_lct_ndarray_ConstP.Constant1_Value, 1, 2, 3);

```

For more information, see [Integrate External Code Using Legacy Code Tool](#).

### Element-Wise Operations as Inputs to Intrinsic Functions

In previous releases, element-wise operations were performed in temporary variables before being used as inputs in an intrinsic function call. In R2012a, element-wise operations are performed within the intrinsic function call to improve memory usage and execution speed.

For example, in previous releases when you generated code for the following MATLAB code:

```
function y = matrixExpand(u1, u2)
```

```
eml.varsize('u1', [4, 8, 10]);  
eml.varsize('u2', [4, 8, 10]);  
y = isnan(u1 + u2);
```

element-wise operations were stored in a temporary variable, `x_data`, which became the input to the generated intrinsic function, `muDoubleScalarIsNan`:

```
for (i = 0; i <= loop_ub; i++) {  
    x_data[i] = u1_data[i] + u2_data[i];  
}  
...  
for (i = 0; i <= loop_ub; i++) {  
    y_data[i] = muDoubleScalarIsNaN(x_data[i]);  
}
```

In R2012a, the temporary variable is eliminated in the generated code and the element-wise operations occur in the function call input:

```
for (i = 0; i <= loop_ub; i++) {  
    y_data[i] = muDoubleScalarIsNaN(u1_data[i] + u2_data[i]);  
}
```

## Enhancements to Custom Storage Classes in Simulink and mpt Packages

In this release, enhancements have been made to the following custom storage classes (CSCs) in the Simulink package.

- **Owner** property added to `Const`, `Volatile`, `ConstVolatile`, `ExportToFile`
- **Definition file** property added to `Const`, `Volatile`, `ConstVolatile`, `ExportToFile`
- **Header file** property added to `Const`, `Volatile`, `ConstVolatile`, `Define`

The following enhancements have been made to CSCs in the mpt package

- **Owner** property has been added to `ExportToFile`
- Settings for the **Owner** and **Definition file** properties for `Global`, `Custom`, `Volatile`, and `ConstVolatile` CSCs have been moved from the **Other Attributes** tab to the **General** tab of the Custom Storage Class Designer.

## Code Generation Report Includes Simulink Web View

R2012a supports integration of the Simulink Web view into the code generation report. You can view the generated code and model in a single web browser window without MATLAB and Simulink installed on your computer.

To generate a code generation report with the model Web view, on the **Code Generation > Report** pane of the model configuration parameters, select:

- **Create code generation report**
- **Generate model Web view**
- **Open report automatically** (optional)

For navigation between the generated code and the model in the Web view, select

- **Code-to-model**
- **Model-to-code**

For more information, see *Include Model Web View in HTML Code Generation Report*. The model Web view requires a Simulink Report Generator license.

## **LDRA Testbed Code Coverage Annotations in Code Generation Report**

If you specify the LDRA Testbed code coverage tool for a SIL/PIL simulation, the code generation report provides summary data and code annotations with LDRA Testbed coverage information. Each code annotation is associated with a code feature and indicates the nature of the feature coverage during code execution. See *Code Coverage Summary and Annotations in Code Generation Report*.

You should not use the code generation report alone to check that your coverage goals have been achieved. You must refer to the LDRA Testbed Report. See *View Code Coverage Information at the End of SIL or PIL Simulations*.

## **Generated Identifiers Enhancements**

### **Simplified Identifiers for Model Reference Code**

Previously, model reference identifiers were generated with the `mr_` prefix. In R2012a, code generation no longer includes the `mr_` prefix to identifiers. This naming convention is now consistent with the code generation of subsystem identifiers and other identifiers. For more information, see *Configuring Generated Identifiers*.

### **Consistent Identifiers for Comparing Generated Code**

To generate unique identifiers in the generated code, the code generation process inserts a mangling string in an identifier name. Previously, the mangling string was generated using the full block path name, which included the model name. In R2012a, the mangling

string uses the Simulink Identifier (SID), which is unique within the model. This mangling string allows for consistent identifiers for similar or derived models, because the SID is persistent even if you change the name of the model. If you create another model using **Save As**, the SID is preserved for each block. For blocks in a subsystem, the SID is preserved whether you build the subsystem or build the model containing the subsystem.

For example, you might want to make a structural change to a model and then see the impact of the change on the generated code. You can save your model using **Save As** and make a change to the saved model. To see only the change in the generated code due to the change in the model, you can compare the generated code from the original and derived model. Before R2012a, the identifiers from the derived model were different, because the mangling string included the different model names. It was difficult to see only the difference in the generated code from the change in the model. Now, when you compare the generated code for the two models, the difference is just the code resulting from the change in the derived model.

If you have an Embedded Coder license, see [Configure Generated Identifiers in Embedded System Code](#) for more information on customizing generated identifiers.

## Code Replacement Enhancements

R2012a provides the following enhancements to code replacement library support.

### Target Function Libraries Renamed to Code Replacement Libraries

In R2012a, target function libraries (TFLs) are renamed to code replacement libraries (CRLs). The change is reflected in software, demos, and documentation. The changes include the following:

- The model configuration parameter **Target function library** (TargetFunctionLibrary) is renamed to **Code replacement library** (CodeReplacementLibrary). The command line parameter TargetFunctionLibrary is still supported, but when you save a model, the library value is saved using the parameter CodeReplacementLibrary.
- The code replacement demo `rtwdemo_tfl_script` is renamed to `rtwdemo_crl_script`, and the `rtwdemo_tfl*` models associated with the demo are renamed to `rtwdemo_crl*`. For example, the model `rtwdemo_tfladdsub` is renamed to `rtwdemo_crladdsub`.
- The code replacement demo `coderdemo_tfl` is renamed to `coderdemo_crl`.

- The Target Function Library (TFL) Viewer is renamed to Code Replacement Viewer.

Code replacement related items that have *not* been renamed include code replacement classes, functions, and commands. Examples include the `RTW.Tf1COperationEntry` class, the `setTf1CFunctionEntryParameters` function, and the `RTW.viewTf1` command.

### Enhanced Code Replacement Traceability

R2012a provides enhanced code replacement traceability, using the model option **Summarize** which blocks triggered code replacements, which is located on the **Code Generation > Report** pane of the Configuration Parameters dialog box. When you select **Summarize which blocks triggered code replacements**:

- Code generation includes a *code replacement report* in the HTML code generation report for your model.
- Code replacement trace information is generated for viewing in the **Trace Information** tab of the Code Replacement Viewer.

The code replacement report lists replacement functions and their associated blocks. You can use the report to:

- Determine which replacement functions were used in the generated code.
- Trace each replacement instance back to the Simulink block that triggered the replacement.

For more information, see *Analyze Code Replacements in the Generated Code*

The **Trace Information** tab of the Code Replacement Viewer lists **Hit Source Locations** and **Miss Source Locations**. The Viewer provides links to each source location (the source block for which code replacement was considered) and, for misses, lists a **Miss Reason**. For example, if a rounding mode setting did not match between a CRL entry and a block, the Viewer displays a reason similar to the following: “Mismatched rounding mode: actual 'RTW\_ROUND\_SIMPLEST', expected 'RTW\_ROUND\_CEILING'.” After generating code for your model, you can open the Code Replacement Viewer for viewing hits and misses using the following commands:

```
>> crl=get_param('mode1','TargetFcnLibHandle')
>> RTW.viewTf1(crl)
```

When debugging a CRL entry, you can use code replacement report information together with hits and misses information in the Code Replacement Viewer to determine why a replacement function was not used in the generated code.

For more information, see [Trace Code Replacements Generated Using Your Code Replacement Library and Determine Why Code Replacement Functions Were Not Used](#).

### **Code Replacement Support for Simulink Matrix Division and Inversion Operators**

Embedded Coder software now provides Simulink code replacement support for the following nonscalar division and inversion operators:

<b>Operator</b>	<b>Key</b>
Matrix right division (/)	RTW_OP_RDIV
Matrix left division (\)	RTW_OP_LDIV
Matrix inversion (inv)	RTW_OP_INV

For more information, see [Map Nonscalar Operators to Target-Specific Implementations](#).

### **Code Replacement Support for MATLAB Coder `fix`, `hypot`, `round`, and `sign` Functions**

Embedded Coder software now provides MATLAB Coder code replacement support for `fix`, `hypot`, `round`, and `sign` functions.

### **Integer Functions Now Return Real-World Values**

The following functions now return real-world values instead of stored integer values: `int8`, `int16`, `int32`, `int64`, `uint8`, `uint16`, `uint32`, and `uint64`.

## **Compatibility Considerations**

In code generation with MATLAB Coder or Simulink Coder, if you used a CRL to replace a cast in your replacement function, silent incorrect numerical results may occur. The numerical results will not change if the input `fi` object has binary-point scaling and zero fractional length. To optimize code generation, these integer functions now use floor rounding, instead of nearest rounding, when the input fraction length equals 0. You should reevaluate your integer cast replacement functions and update their replacement tables.

## **SIL and PIL Enhancements**

R2012a supports the following enhancements for software-in-the loop (SIL) and processor-in-the-loop (PIL) simulations.



## SIL and PIL Test Harness Files in Code Generation Report

For top-model and Model block SIL and PIL simulations, the software now displays test harness files and the corresponding static code metrics in the code generation report.

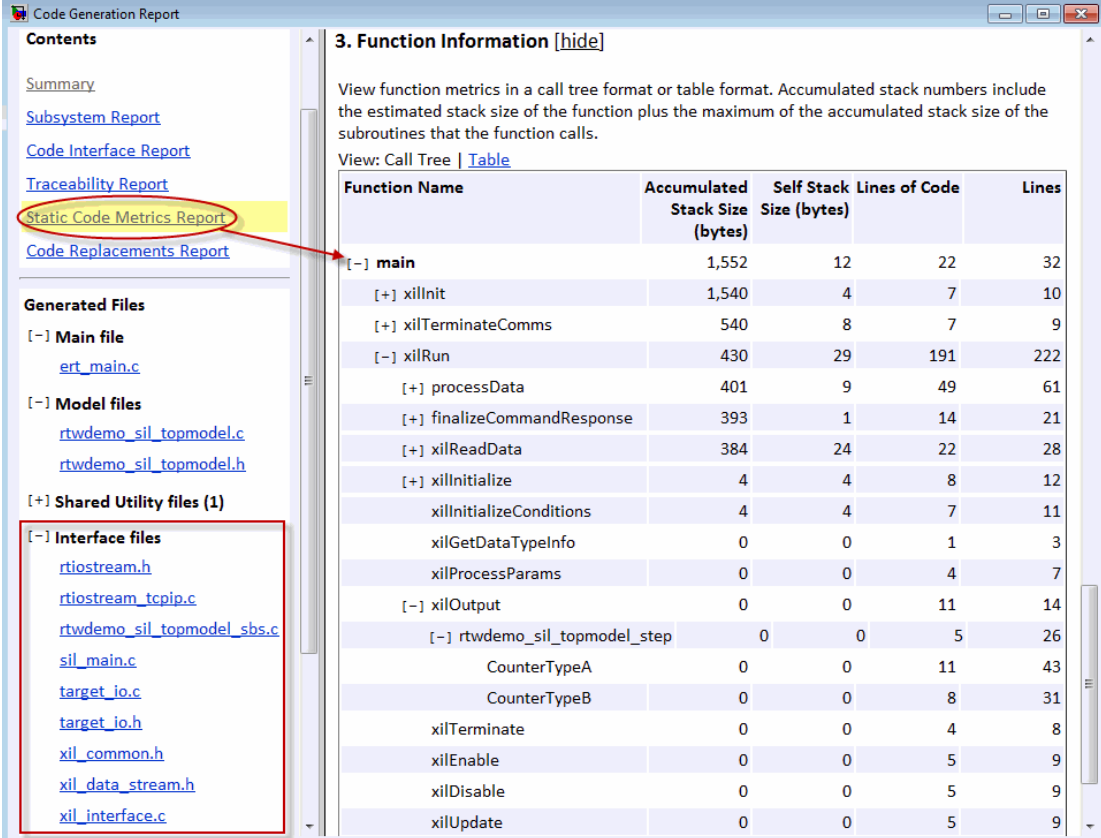

**3. Function Information [hide]**

View function metrics in a call tree format or table format. Accumulated stack numbers include the estimated stack size of the function plus the maximum of the accumulated stack size of the subroutines that the function calls.

View: Call Tree | [Table](#)

Function Name	Accumulated Stack Size (bytes)	Self Stack Size (bytes)	Lines of Code	Lines
[ - ] main	1,552	12	22	32
[ + ] xilInit	1,540	4	7	10
[ + ] xilTerminateComms	540	8	7	9
[ - ] xilRun	430	29	191	222
[ + ] processData	401	9	49	61
[ + ] finalizeCommandResponse	393	1	14	21
[ + ] xilReadData	384	24	22	28
[ + ] xilInitialize	4	4	8	12
xilInitializeConditions	4	4	7	11
xilGetTypeInfo	0	0	1	3
xilProcessParams	0	0	4	7
[ - ] xilOutput	0	0	11	14
[ - ] rtwdemo_sil_topmodel_step	0	0	5	26
CounterTypeA	0	0	11	43
CounterTypeB	0	0	8	31
xilTerminate	0	0	4	8
xilEnable	0	0	5	9
xilDisable	0	0	5	9
xilUpdate	0	0	5	9

This feature helps you to:

- Understand and review the SIL and PIL verification process.
- See how your registered custom target connectivity files fit into the target application that runs during a SIL or PIL simulation.

This feature is not available for simulations that you run with the PIL block. For more information, see [View Test Harness Files in Code Generation Report](#).

## **PIL Support for Code Coverage with LDRA Testbed**

The target connectivity API supports code coverage with LDRA Testbed for the following types of PIL simulation:

- Top-Model PIL
- Model block PIL

Previously, support for code coverage during a PIL simulation was only available in special cases, where your PIL application could write directly to the host file system.

You can run PIL simulations on simulator or target hardware and collect code coverage metrics to support high integrity workflows, for example, DO-178B and ISO 26262. For more information, see *Use a Code Coverage Tool in SIL and PIL Simulations*.

## **Seamless Switching Between SIL and PIL for Top-Model and Model Block**

If you select **Configuration Parameters > SIL and PIL Verification > Enable portable word sizes**, you can switch between the SIL and PIL simulation modes without:

- Changing configuration parameters of your model
- Regenerating code (if your model is up-to-date)

This feature:

- Applies only to top-model and Model block SIL/PIL
- Requires that the code can be compiled by both the host computer and the target platform

If your target uses code that cannot be compiled on the host, then you see compilation errors when you try to simulate the model in SIL mode. You might be able to work around this problem by adding the source code files to the `SkipForSil` group in the build information object `RTW.BuildInfo`. The SIL build on the host platform does not compile source files present in the `SkipForSil` group. See *Code that the Host Cannot Compile*.

## **Enhanced Hardware Implementation Support**

### **Host and Target Floating Point Data Type Sizes**

The host and target floating point data type sizes must be the same. Previously, a mismatch would produce undefined behaviour resulting in a simulation failure. Now, the

software generates an error with a clear message when the host and target data types are *not*:

- 32 bits for `single`
- 64 bits for `double`

For more information, see [Hardware Implementation Support](#).

### **Word-Addressable Targets**

Previously, the target connectivity API did not support word-addressable targets for PIL simulations or SIL simulations with `PortableWordSizes` enabled. This limitation has been removed.

In addition, data type sizes that are smaller than the target word sizes are now supported. See [Hardware Implementation Support](#).

The software uses the MATLAB host byte order when sending words through the `rtIOStream` API. For information about host byte ordering, see `computer` in the MATLAB Reference documentation.

### **Top-Model Output Limitations Removed**

Previously, in a top-model SIL/PIL simulation, not all signal and output logging fields matched the fields produced by a Normal simulation. For example:

- With signal logging, the software would add the suffix `_wrapper` to the block path for signals in `logouts`.
- With output logging, if the save format was `Structure` or `Structure with time`, the software would add the suffix `_wrapper` to the block name for signals in `yout`.

These limitations are not present in R2012a, except if you do one of the following:

- Specify the signal logging format to be `ModelDataLogs`. In this case, `yout` will still contain references to the wrapper model. You should use the `Dataset` signal logging format. See `Simulink.SimulationData.Dataset` in the Simulink reference documentation.
- Run command line simulations using the `sim` command but without specifying the single-output format. See [Using the sim Command](#) in the Simulink documentation.

## Model Block SIL/PIL Support for Absolute Time

Previously, you could not run a Model block in the SIL or PIL mode if the Model block contained Simulink blocks that depended on absolute time. Now, Model block SIL/PIL supports absolute time except for the following case: the Model block contains Simulink blocks that require absolute time **and** the Model block is conditionally executed. See Configuration Parameters Support.

## Changes for ERT and ERT-Based Targets

In R2012a, the simplified model call interface used by ERT targets has been further streamlined. (The simplified call interface also is now available to GRT target users — see Simplified Call Interface for Generated Code in the R2012a Simulink Coder Release Notes.) With the call interface enhancements come some compatibility considerations for static ERT main program (`ert_main.c`) files created before R2012a.

## Compatibility Considerations

### ERT Main Programs Now Include `rtmodel.h` Instead of `autobuild.h`

- In previous releases, GRT-based main programs such as `grt_main.c` and `grt_malloc_main.c` included `rtmodel.h` (which includes `model.h`) to access model-specific data structures and entry points. However, the static ERT main program `ert_main.c` included a different file, `autobuild.h`.
- Beginning in R2012a, GRT and static ERT main programs include `rtmodel.h`. If you have a static ERT main program created before R2012a that you want to use with R2012a generated code, update the main program to include `rtmodel.h` instead of `autobuild.h`.

**`tid` Argument to Model Step or Model Output/Update Function No Longer Generated** As part of streamlining the model call interface, code generation no longer generates the `tid` argument to `model_step` or `model_output/model_update` functions in multirate, single-tasking models. If you have a static ERT main program created before R2012a that you want to use with R2012a generated code, update the main program to remove the `tid` argument in model function calls.

**`firstTime` Argument to Model Initialize Function No Longer Generated** As part of streamlining the model call interface, code generation no longer generates the `firstTime` argument to the `model_initialize` function. If you have a static ERT main program created before R2012a that you want to use with R2012a generated code, update

the main program to remove the *firstTime* argument in `model_initialize` function calls.

---

**Note:** The target configuration parameter `ERTFirstTimeCompliant` and the model configuration parameter `IncludeERTFirstTime` will be removed from the Embedded Coder software in a future release.

---

**MAT-file Logging and External Mode Calls Moved from Model Code to Main Program** As part of streamlining the model call interface, some MAT-file logging and External mode calls have been moved from the generated model code in `model.c` or `.cpp` to the main program code in `ert_main.c`. MAT-file logging and External mode calls are not heavily used in production code environments. However, if you have a static ERT main program created before R2012a that you want to use with R2012a generated code, and if you do want to support MAT-file logging or External mode, update the main program to add the MAT-file logging and External mode calls.

## Changes for Embedded IDEs and Embedded Targets

- “Support Added for GCC 4.4 on Host Computers Running Linux with Eclipse IDE” on page 12-13
- “Support Added for Using Processor-in-the-Loop (PIL) with Serial Communication Interface (SCI) for TI C2000 Processors” on page 12-13
- “Support Removed for Freescale MPC5xx” on page 12-14
- “Limitation: Parallel Builds Not Supported for Embedded Targets” on page 12-14

### Support Added for GCC 4.4 on Host Computers Running Linux with Eclipse IDE

Embedded Coder software now supports version 4.4 of GCC on host computers running Linux with Eclipse IDE. This support is on both 32-bit and 64-bit host Linux platforms.

If you were using an earlier version of GCC on Linux with Eclipse, upgrade to GCC 4.4.

### Support Added for Using Processor-in-the-Loop (PIL) with Serial Communication Interface (SCI) for TI C2000 Processors

You can now perform PIL simulation over a SCI interface with Texas Instruments C280x, C2802x, C2803x, C28x3x, c2834x processors. Previously, this capability was supported only for TI C28035 and C28335 processors.

## Support Removed for Freescale MPC5xx

This release removes support for the Freescale MPC5xx processor family from the Embedded Coder product.

Attempting to generate code from models that contain blocks for Freescale MPC5xx hardware produces an error message.

## Limitation: Parallel Builds Not Supported for Embedded Targets

The Simulink Coder product provides an API for MATLAB Distributed Computing Server™ and Parallel Computing Toolbox™ products. The API allows these products to perform parallel builds that reduce build time for referenced models. However, the API does not support parallel builds for models whose **System target file** parameter is set to `idelink_ert.tlc` or `idelink_grt.tlc`. Thus, you cannot perform parallel builds for Embedded Targets.

## New and Enhanced Demos

The following demos have been added in R2012a:

Demo...	Shows How You Can...
<code>rtwdemo_roll_axis</code>	Generate code for a roll axis autopilot control system. The <code>rtwdemo_roll</code> model represents a basic roll axis autopilot with two operating modes: roll attitude hold and heading hold. <code>rtwdemo_roll</code> replaces <code>rtwdemo_f14</code> .
<code>c28335_pmsmfoc_script</code>	Schedule a multi-rate controller for a permanent magnet synchronous machine (PMSM) motor control application that runs on a Texas Instruments F28335 processor. To get this demo, use <code>targetinstaller</code> or <code>supportPackageInstaller</code> to install the <i>Embedded Coder Support Package for Texas Instruments C2000 Processors</i> .

The following demos have been enhanced in R2012a:

Demo...	Now...
<code>coderdemo_cr1</code>	Reflects the renaming of target function libraries (TFLs) to code replacement libraries (CRLs).

Demo...	Now...
rtwdemo_crl_script	<ul style="list-style-type: none"><li>• Reflects the renaming of target function libraries (TFLs) to code replacement libraries (CRLs).</li><li>• Illustrates code replacement for Simulink matrix division and inversion operators.</li></ul>
rtwdemo_pmsmfoc_script	Added torque and position control modes to controller, parameterized motor and sensor data, and added support for specifying baud rate in example PIL implementation.
rtwdemo_radar	Shows how to simulate and generate code for the model <code>rtwdemo_eml_aero_radar</code> , which contains a MATLAB script.
rtwdemo_configuration_set	Shows how to use the Code Generation Advisor and to automate the process of configuring a model for simulation and code generation.

## Check bug reports for issues and fixes

Software is inherently complex and is not free of errors. The output of a code generator might contain bugs, some of which are not detected by a compiler. MathWorks reports critical known bugs brought to its attention on its Bug Report system at [www.mathworks.com/support/bugreports/](http://www.mathworks.com/support/bugreports/). Use the Saved Searches and Watched Bugs tool with the search phrase "Incorrect Code Generation" to obtain a report of known bugs that produce code that might compile and execute, but still produce wrong answers.

The bug reports are an integral part of the documentation for each release. Examine periodically all bug reports for a release, as such reports may identify inconsistencies between the actual behavior of a release you are using and the behavior described in this documentation.

In addition to reviewing bug reports, you should implement a verification and validation strategy to identify potential bugs in your design, code, and tools.



# R2011b

**Version: 6.1**

**New Features**

**Bug Fixes**

**Compatibility Considerations**

## Static Code Metrics in Code Generation Report

The HTML code generation report now includes a static code metrics report. The static code metrics include: number of source code files, number of lines of code, list of global variables, functions in a call tree format, and the estimated stack size required for a function.

To generate the static code metrics report, on the **Code Generation > Report** pane of the Configuration Parameters dialog box, select the **Static code metrics** parameter and build your model. For more information, see [Analyze Static Code Metrics of the Generated Code](#).

## AUTOSAR Enhancements

### Import and Export of AUTOSAR Sensor/Actuator Components

Embedded Coder now supports Sensor/Actuator Software Components. The key difference between a sensor/actuator component and an application component is that a sensor/actuator component can access the I/O hardware abstraction part within the ECU abstraction layer.

This support allows you to import sensor/actuator components, implement and test designs within Simulink, and export sensor/actuator components. For more information, see [Use the Configure AUTOSAR Interface Dialog Box](#).

### Improved Simulink Library Support for Multiple Runnables

Previously, Embedded Coder did not support the creation of multiple runnables from subsystems with links to Simulink library blocks. For example, you had to disable and break links to library blocks in order to configure and validate the subsystems as AUTOSAR runnables.

Now, the software supports the creation of multiple runnables when:

- The wrapper subsystem (containing function-call subsystems) is a link to a library block
- The function-call subsystems (within the wrapper subsystem) are links to library blocks

For more information, see [Configure Multiple Runnables in the Embedded Coder documentation](#).

## **AUTOSAR Schema Version 3.2**

The software now supports AUTOSAR schema version 3.2 (3.2.1). See [Select an AUTOSAR Schema](#).

### **Export AUTOSAR XML as Single File**

When you export an AUTOSAR Software Component, you can generate XML as either a set of files (default) or a single file. The latter option is new. For more information, see [Use the Configure AUTOSAR Interface Dialog Box](#).

## **SIL and PIL Enhancements**

R2011b supports the following enhancements for software-in-the loop (SIL) and processor-in-the-loop (PIL) simulations.

### **Code Execution Profiling of Functions in Subsystems and Model Blocks**

Previously, you could generate a profile of code execution times only for tasks within your generated code (for example, the step function for a sample rate). Now, you can also produce a profile of code execution times for functions generated from atomic subsystems and model reference hierarchies within the top model. The software places instrumentation probes inside these functions and calculates execution times during a SIL or PIL simulation. At the end of the simulation, you can view an HTML report and analyze execution times within the MATLAB environment:

- The HTML report provides a summary of maximum and average execution times, which allows you to identify code that requires optimization
- The supplied APIs allow you to carry out further analysis of time measurements.

For more information, see [Code Execution Profiling in the Embedded Coder documentation](#).

### **Code Coverage with LDRA Testbed**

You can measure code coverage using the LDRA Testbed from LDRA Software Technology. For more information, see [Code Coverage](#).

### **BitField and GetSet Custom Storage Classes**

The software previously did not support the `BitField` and `GetSet` custom storage classes. Now, the software supports these custom storage classes for all types of SIL and

PIL simulations, with one limitation. `GetSet` behavior for the SIL block is different from top-model SIL/PIL, Model block SIL/PIL, and PIL block:

- SIL block — The C definitions of the `Get` and `Set` functions that you provide form part of the algorithm under test.
- Other types of SIL/PIL — The SIL/PIL test harness automatically provides C definitions of the `Get` and `Set` functions that are used during SIL/PIL simulations. In addition, the software supports only *scalar* signals, parameters and global data stores.

For more information, see [I/O Support](#) and [GetSet Custom Storage Class](#).

### Model Blocks with Variable-Size Signals

You can run Model block SIL and PIL simulations where the Model block contains variable-size signals. On the **Simulation > Configuration Parameters > Model Referencing** pane, in the **Propagate sizes of variable-size signals** field, you must specify `During execution`. See [I/O Support](#).

### Verification of Generated C++ Code

Previously, support for C++ was restricted to simulations with the SIL block. Now, you can verify generated C++ code using all types of SIL and PIL:

- Top-model
- Model block
- SIL or PIL block

As before, only the SIL block supports C++ encapsulation. See [Configuration Parameters Support](#).

## Generate Multitasking Code for Concurrent Execution on Multicore Processors

The Embedded Coder product extends the concurrent execution modeling capability of the Simulink product. With Embedded Coder, you can generate multitasking code that uses POSIX threads (Pthreads) for concurrent execution on multicore processors running Linux or VxWorks.

See [Configuring Models for Targets with Multicore Processors](#).

## Changes for Embedded IDEs and Embedded Targets

- “64-bit Version of Embedded Coder Supports Analog Devices VisualDSP++ and Texas Instruments Code Composer Studio 3.3 and 4.0” on page 13-5
- “Support Added for Wind River VxWorks 6.8” on page 13-6
- “Support Added for Serial Communications Interface with Processor-in-the-loop (PIL) for Texas Instruments™ C28035 and C28335” on page 13-6
- “New Target Function Library for Intel IPP/SSE (GNU)” on page 13-6
- “Support Added for Single Instruction Multiple Data (SIMD) with ARM Cortex-A8, ARM Cortex-A9 , and Intel Processors” on page 13-6
- “Support Removed for Altium TASKING” on page 13-7
- “Support Removed for Infineon C166” on page 13-7
- “Support Ending for Green Hills MULTI in a Future Release” on page 13-7
- “Support Ending for Freescale MPC5xx in a Future Release” on page 13-7

### **64-bit Version of Embedded Coder Supports Analog Devices VisualDSP++ and Texas Instruments Code Composer Studio 3.3 and 4.0**

Installing MATLAB & Simulink on a 64-bit Windows computer automatically installs the 64-bit versions of your MathWorks products, including Embedded Coder software. Now, you can use the 64-bit version of Embedded Coder software with the following 32-bit IDEs/tool chains:

- Texas Instruments Code Composer Studio 3.3
- Texas Instruments Code Composer Studio 4.0
- Analog Devices VisualDSP++ 5.0 (update 8)

Previously, you had to install the 32-bit versions of your MathWorks products to use Embedded Coder software with these IDEs.

For more information, see <http://www.mathworks.com/hardware-support/texas-instruments.html> and <http://www.mathworks.com/hardware-support/analog-devices.html>.

Also, check the Texas Instruments and Analog Devices Web sites for support information about using their tools on 64-bit Windows platforms.

### **Support Added for Wind River VxWorks 6.8**

You can automatically generate and integrate code with the Wind River VxWorks 6.8 RTOS using makefiles via the XMakefiles feature. For more information, see [Choosing an XMakefile Configuration and Working with Wind River VxWorks RTOS](#).

### **Support Added for Serial Communications Interface with Processor-in-the-loop (PIL) for Texas Instruments™ C28035 and C28335**

This release adds support for Serial Communication Interface (SCI) communications during processor-in-the-loop (PIL) simulations with Texas Instruments™ C28035 and C28335 microcontrollers. Using SCI for PIL simulations is much faster than using an IDE debugger for PIL.

For more information, see [Serial Communication Interface \(SCI\) for Texas Instruments C2000, Example — Performing a Model Block PIL Simulation via SCI Using Makefiles](#), and the `fuelsys_pil` demo.

### **New Target Function Library for Intel IPP/SSE (GNU)**

This release adds a new Target Function Library (TFL), `Intel IPP/SSE (GNU)`, for the GCC compiler. This library includes the Intel Performance Primitives (IPP) and Streaming SIMD Extensions (SSE) code replacements.

For more information, see [Code Replacement Library \(CRL\) and Embedded Targets Desktop Targets](#).

### **Support Added for Single Instruction Multiple Data (SIMD) with ARM Cortex-A8, ARM Cortex-A9 , and Intel Processors**

This release adds support for the Single Instruction Multiple Data (SIMD) capabilities of the ARM Cortex-A8, ARM Cortex-A9 , and Intel processors. The use of SIMD instructions increases throughput compared to traditional Single Instruction Single Data (SISD) processing.

The following TFLs (code replacement libraries) optimize generated code for SIMD:

- `GCC ARM Cortex-A8` — The GCC compiler and the ARM Cortex-A8 embedded processor
- `GCC ARM Cortex-A9` — The GCC compiler and the ARM Cortex-A9 embedded processor
- `Intel IPP/SSE (GNU)` — The GCC compiler and the Intel Performance Primitives (IPP) and Streaming SIMD Extensions (SSE)

The performance of the SIMD-enabled executable depends on several factors, including:

- Processor architecture of the target
- Optimized library support for the target
- The type and number of TFL replacements in the generated algorithmic code

Evaluate the performance of your application before and after using the TFL.

To use SIMD capabilities, enable the corresponding TFLs as described in Code Replacement Library (CRL) and Embedded TargetsDesktop Targets.

### **Support Removed for Altium TASKING**

Support for the Altium<sup>®</sup> TASKING IDE has been removed from the Embedded Coder product.

### **Support Removed for Infineon C166**

Support for the Infineon<sup>®</sup> C166<sup>®</sup> processor family has been removed from the Embedded Coder product.

### **Support Ending for Green Hills MULTI in a Future Release**

Support for the Green Hills MULTI IDE will end in a future release of the Embedded Coder product.

### **Support Ending for Freescale MPC5xx in a Future Release**

Support for the Freescale MPC5xx processor family will end in a future release of the Embedded Coder product.

## **Saturation Control of Stateflow Data**

A new property for Stateflow charts, **Saturate on integer overflow**, enables you to control the behavior of data with signed integer types when overflow occurs. This check box appears in the Chart properties dialog box.

Check Box	When to Use This Setting	Overflow Handling	Example of a Result
Selected	Overflow is possible for data in your Stateflow chart and you want	Overflows saturate to either the minimum or	An overflow associated with a signed 8-bit integer saturates to -128 or +127.

Check Box	When to Use This Setting	Overflow Handling	Example of a Result
	explicit saturation protection in the generated code.	maximum value that the data type can represent.	
Cleared	You want to optimize efficiency of the generated code.	The behavior depends on the C compiler you use for generating code.	The number 130 does not fit in a signed 8-bit integer and wraps to $-126$ .

Arithmetic operations in the chart for which you can enable saturation protection are:

- Unary minus:  $-a$
- Binary operations:  $a + b$ ,  $a - b$ ,  $a * b$ ,  $a / b$ ,  $a ^ b$
- Assignment operations:  $a += b$ ,  $a -= b$ ,  $a *= b$ ,  $a /= b$

For new charts, this check box is selected by default. When you open charts saved in previous releases, the check box is cleared to maintain backward compatibility.

For more information, see *Handling Integer Overflow for Chart Data* in the *Stateflow User's Guide*.

## Custom Storage Class Properties for Managing Data Ownership and Definition

In R2011b, use the **Owner** and **Definition File** properties of custom storage classes to manage the definition and ownership of `mpt` data objects in generated code.

Previously, you could include the data definitions in generated code but could not specify the model that defined the data. Now, Embedded Coder creates the data definitions in the generated code according to the **Owner** property.

The **Owner** property of a custom storage class specifies the model that owns and defines the data in the generated code. The **Definition File** property specifies a name for the data definition file that Embedded Coder generates.

## Compatibility Considerations

- If your legacy code exports data definitions to generated code and you now specify the **Owner** property, your generated code might have duplicate data definitions. This



duplication causes a link error. In this case, remove the data definitions from the legacy code.

- If your legacy code does not export data definitions to generated code and you now specify the **Owner** property, your generated code might not contain data definitions. This mismatch causes a link error. In this case, add the missing data definitions to your legacy code.

## Export Data Declarations to Shared Header File for Code Generation with Model Reference

When generating code with model reference, you can export shared data declarations to a specific header file in a shared directory.

Specify a data declaration header file in the following ways:

- For a data object: In the **Code generation** options section of the data object dialog
- For a model: In the **Code Generation > Code Placement** section of the **Configuration Parameters** dialog

Specify the option to use a **Shared location** in the field **Shared code placement** in **Code Generation > Interface** section of the **Configuration Parameters** dialog.

## Target Function Library Code Replacement Enhancements

R2011b provides the following enhancements to code replacement using target function libraries (TFLs).

### Code Replacement Tool for Creating and Managing TFL Tables

R2011b provides the Code Replacement Tool, which helps you create and manage the code replacement tables that make up a TFL. You can:

- Create a new code replacement table or import existing tables.
- Add, modify, and delete table entries. Each table entry represents a potential code replacement for a single function or operator. You can manage multiple tables together and copy and paste entries between tables.
- Validate tables and table entries.

- Save code replacement tables as MATLAB files.
- Generate the customization file you use to register your code replacement tables with code generation software.

Each code replacement table contains one or more table entries. Each table entry represents a potential replacement, during code generation, of a single function or operator by a custom implementation. For each table entry, you provide:

- **Mapping Information**, which relates a conceptual view of the function or operator (similar to the Simulink block view of the function or operator) to a custom implementation of that function or operator.
- **Build Information**, which provides header, source, or link information required for building the custom implementation.

You can open the Code Replacement Tool in the following ways:

- Go to the **Interface** pane of the Configuration Parameters dialog box and click the **Custom** button, which is located to the right of the **Target function library** parameter.
- Use the MATLAB command `crtool`.

For more information about creating code replacement tables for TFLs, see [Create and Manage Code Replacement Tables Using the Code Replacement Tool](#).

### **Ability to Align Data Objects to TFL-Specified Boundaries to Boost Code Performance**

R2011b provides the ability to align data objects passed into a TFL replacement function to a specified boundary. This allows you to take advantage of target-specific function implementations that require data to be aligned in order to optimize application performance. To configure data alignment for a function implementation:

- 1 Specify the data alignment requirements in a TFL table entry. Alignment can be specified separately for each implementation function argument or collectively for all function arguments.
- 2 Specify the data alignment capabilities and syntax for one or more compilers, and include the alignment specifications in a TFL registry entry in an `sl_customization.m` or `rtwTargetInfo.m` file.

For more information on specifying data alignment requirements and compiler alignment attributes, see [Configure Data Alignment for Function Implementations](#).

For additional examples of configuring data alignment for function implementations, see the demo `rtwdemo_tfl_script`.

### Support for Replacing Element-wise Matrix Multiply

TFLs support several nonscalar operators for replacement with custom library functions in generated model code. R2011b adds support for replacing element-wise matrix multiplication operations (`. *` operator in element-wise mode) with custom implementations. For more information, see [Map Nonscalar Operators to Target-Specific Implementations](#).

## Code Generation Enhancements

### Redundant Condition Checks

Multiple checks of the same condition are difficult to avoid in modeling. For example, a common modeling pattern is Switch blocks sharing the same condition check. Previously, the generated code for multiple Switch blocks produced multiple `if` statements.

```
if (cond) {
    true_statement1;
} else {
    false_statement1; }
if (cond) {
    true_statement2;
} else {
    false_statement2;
}
```

In R2011b, the generated code combines these condition checks. For example, the generated code for Switch blocks with a common condition combines these multiple `if` statements.

```
if (cond) {
    true_statement1;
    true_statement2;
}
else {
    false_statement1;
    false_statement2;
}
```

This optimization reduces code size and execution time. As a result, other optimizations for condition expressions or merged branches are enabled which reduce data copies and RAM usage.

## Loop Fusion

R2011b provides more precise data dependency analysis of the data and signals of a nested Simulink bus. This enhancement enables more loop fusion in the generated code which reduces code execution time and ROM, and improves code readability.

## Invariant Condition Check Lifting

When a condition check is invariant to the enclosing loop and you specify loops to be unrolled, the code generator lifts the check out of the loop. This enhancement reduces ROM, enables additional optimizations, and improves execution speed and code readability. For more information on loop unrolling, see [Configure Loop Unrolling Threshold](#).

## Parameter Pooling for Stateflow and Interpreted MATLAB Function Blocks

Parameter pooling now occurs for Simulink matrix constants used as Stateflow graphical function arguments. This enhancement reduces RAM and ROM, and improves thread safety.

## Readability Improvement for Reusable Subsystem Input and Output

The generated code for reusable subsystem input and output now eliminates redundant operators and unnecessary parentheses. This enhancement improves code readability.

## Enhanced Code Generation Optimization Using Minimum and Maximum Values

The **Optimize using specified minimum and maximum values** code generation option now takes into account the minimum and maximum values specified for `Simulink.Parameter` objects even if the object is part of an expression. For example, consider a Gain block with a gain parameter specified as an expression such as  $k1 + 5$ , where `k1` is a `Simulink.Parameter` object with `k1.min = -10` and `k1.max = 10`. If minimum and maximum values of the parameter specified in the parameter dialog box are 0 and 20, the range calculated for this parameter expression is 0 to 15.

For more information, see [Optimize Generated Code Using Specified Minimum and Maximum Values](#).

## New Model Advisor Check for Code Efficiency of Logic Blocks

The Simulink Model Advisor includes the following new check for code efficiency of logic blocks: Check output types of logic blocks. The following blocks in the Simulink Logic and Bit Operations library can use `boolean` or another setting for the output data type:

- Compare To Constant
- Compare To Zero
- Detect Change
- Detect Decrease
- Detect Fall Negative
- Detect Fall Nonpositive
- Detect Increase
- Detect Rise Nonnegative
- Detect Rise Positive
- Interval Test
- Interval Test Dynamic
- Logical Operator
- Relational Operator

Running this Model Advisor check helps you identify logic blocks that do not use `boolean` for the output data type.

For more information about the Model Advisor, see [Consulting the Model Advisor](#) in the Simulink documentation.

## Control of Default Case Generation for Switch Statements in Generated Code for Stateflow Charts

You can specify whether or not to generate default cases for switch statements in the generated code for Stateflow charts. This optimization works on a per-model basis and applies to the code generated for a state that has multiple substates. Use the following check box on the **Code Generation > Code Style** pane of the Configuration Parameters dialog box:

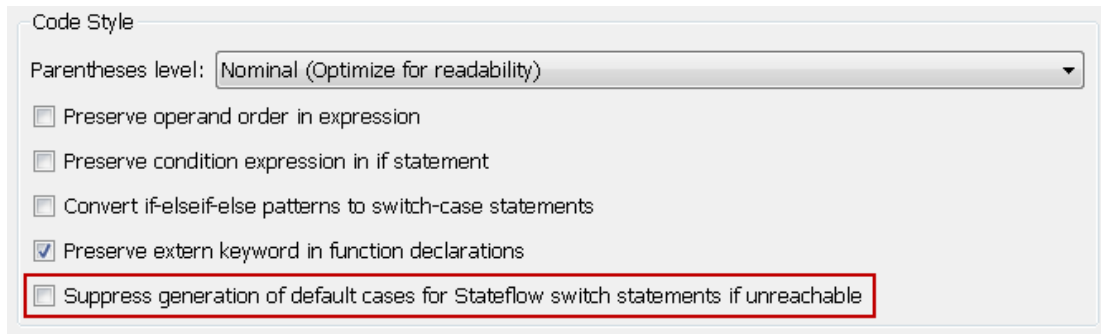

Check Box	When to Use This Setting	Format of Switch Statements
Selected	Provide better code coverage by checking that every branch in the generated code is falsifiable.	Exclude the default case when it is unreachable.
Cleared	Check for MISRA C compliance and provide a fallback in case of RAM corruption.	Include a default case.

For new models, this check box is cleared by default. When you open models saved in previous releases, the check box is also cleared to maintain backward compatibility.

For more information, see Code Generation Pane: Code Style in the Embedded Coder Reference documentation.

## Improvement to Build Process for Conflicting Identifiers

Previously, if your model contained two referenced models with the same input (or output) port names, the model might not build because of potentially conflicting identifiers. The failure to build happens when the generated identifiers exceed the Maximum identifier length. In R2011b, the build process is improved to handle more cases when two referenced models have the same input (or output) port names. For more information, see Model Referencing Considerations.

## Update to Code Generation Verification Class `cgv.Config`

### Compatibility Considerations

The `Connectivity` `cgv.Config` parameter has the following updates:

- `pil` replaces the `custom` value. In R2011b, you can use `custom` without producing a warning or error message.
- The `tasking` value is not available. Specifying `tasking` produces an error.

### License Names Not Yet Updated for Coder Product Restructuring

The Simulink Coder and Embedded Coder license name strings stored in `license.dat` and returned by the `license('inuse')` function have not yet been updated for the R2011a coder product restructuring. Specifically, the `license('inuse')` function continues to return `'real-time_workshop'` for Simulink Coder and `'rtw_embedded_coder'` for Embedded Coder, as shown below:

```
>> license('inuse')
matlab
matlab_coder
real-time_workshop
rtw_embedded_coder
simulink
>>
```

The license name strings intentionally were not changed, in order to avoid license management complications in situations where Release 2011a or higher is used alongside a preR2011a release in a common operating environment. MathWorks plans to address this issue in a future release.

For more information about using the function, see the license documentation.

### New and Enhanced Demos

The following demos have been enhanced in R2011b:

Demo...	Now...
<code>rtwdemo_pmsmfoc_script</code>	Shows how you can perform system-level simulation and algorithmic code generation using Field-Oriented

<b>Demo...</b>	<b>Now...</b>
	Control for a Permanent Magnet Synchronous Machine
<code>rtwdemo_sil_pil_script</code>	Incorporates code execution profiling
<code>rtwdemo_tfl_script</code>	Shows how you can align nonscalar data passed into a target function library (TFL) code replacement function
<code>fuelsys_pil</code>	Incorporates using serial communication interface to communicate during PIL simulation



## Check bug reports for issues and fixes

Software is inherently complex and is not free of errors. The output of a code generator might contain bugs, some of which are not detected by a compiler. MathWorks reports critical known bugs brought to its attention on its Bug Report system at [www.mathworks.com/support/bugreports/](http://www.mathworks.com/support/bugreports/). Use the Saved Searches and Watched Bugs tool with the search phrase "Incorrect Code Generation" to obtain a report of known bugs that produce code that might compile and execute, but still produce wrong answers.

The bug reports are an integral part of the documentation for each release. Examine periodically all bug reports for a release, as such reports may identify inconsistencies between the actual behavior of a release you are using and the behavior described in this documentation.

In addition to reviewing bug reports, you should implement a verification and validation strategy to identify potential bugs in your design, code, and tools.



# R2011a

**Version: 6.0**

**New Features**

**Bug Fixes**

**Compatibility Considerations**

## Coder Product Restructuring

- “Product Restructuring Overview” on page 14-2
- “Resources for Upgrading from Real-Time Workshop Embedded Coder” on page 14-3
- “Migration of Embedded MATLAB Coder Features to MATLAB Coder” on page 14-4
- “Migration of Embedded IDE Link and Target Support Package Features to Simulink Coder and Embedded Coder” on page 14-4
- “Interface Changes Related to Product Restructuring” on page 14-5
- “Simulink Graphical User Interface Changes” on page 14-5

### Product Restructuring Overview

In R2011a, the Embedded Coder product replaces the Real-Time Workshop® Embedded Coder product. Additionally,

- The Simulink Coder product combines and replaces the Real-Time Workshop and Stateflow Coder products
- The Real-Time Workshop facility for converting MATLAB code to C/C++ code, formerly referred to as Embedded MATLAB® Coder, has migrated to the new MATLAB Coder product.
- The previously existing Embedded IDE Link™ and Target Support Package™ products have been integrated into the new Simulink Coder and Embedded Coder products.

The following figure shows the R2011a transitions for C/C++ code generation related products, from the R2010b products to the new MATLAB Coder, Simulink Coder, and Embedded Coder products.

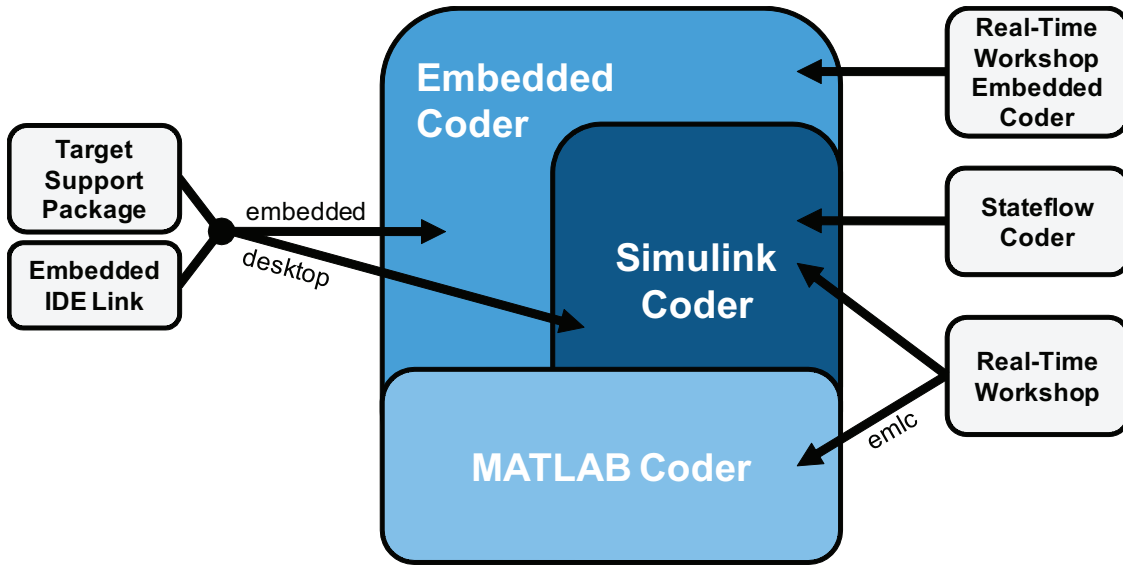

### Resources for Upgrading from Real-Time Workshop Embedded Coder

If you are upgrading to Embedded Coder from Real-Time Workshop Embedded Coder, review information about compatibility and upgrade issues at the following locations:

- *Release Notes for Embedded Coder* (latest release), “Compatibility Summary” section
- On the MathWorks web site, in the Archived documentation, select R2010b, and view the following tables, which are provided in the release notes for Real-Time Workshop Embedded Coder: *Compatibility Summary for Real-Time Workshop Embedded Coder Software*:

This table provides compatibility information for releases up through R2010b.

- If you use the Embedded IDE Link or Target Support Package capabilities that now are integrated into Simulink Coder and Embedded Coder, go to the Archived documentation and view the corresponding tables for Embedded IDE Link or Target Support Package:
  - *Compatibility Summary for Embedded IDE Link* (R2010b)
  - *Compatibility Summary for Target Support Package* (R2010b)

You can also refer to the rest of the archived documentation, including release notes, for the Real-Time Workshop, Stateflow Coder, Embedded IDE Link, and Target Support Package products.

### Migration of Embedded MATLAB Coder Features to MATLAB Coder

In R2011a, the MATLAB Coder function `codegen` replaces the Real-Time Workshop function `emlc`. The `emlc` function still works in R2011a but generates a warning, and will be removed in a future release. For more information, see [Generating C/C++ Code from MATLAB Code](#) in the MATLAB Coder documentation.

### Migration of Embedded IDE Link and Target Support Package Features to Simulink Coder and Embedded Coder

In R2011a, the capabilities formerly provided by the Embedded IDE Link and Target Support Package products have been integrated into Simulink Coder and Embedded Coder. The following table summarizes the transition of the Embedded IDE Link and Target Support Package supported hardware and software into Coder products.

Former Product	Supported Hardware and Software	Simulink Coder	Embedded Coder
Embedded IDE Link	Altium TASKING		x
	Analog Devices VisualDSP++		x
	Eclipse IDE	x	x
	Green Hills MULTI		x
	Texas Instruments Code Composer Studio		x
Target Support Package	Analog Devices Blackfin		x
	ARM		x
	Freescale MPC5xx		x
	Infineon C166		x
	Texas Instruments C2000		x
	Texas Instruments C5000		x
	Texas Instruments C6000		x
	Linux OS	x	x

Former Product	Supported Hardware and Software	Simulink Coder	Embedded Coder
	Windows OS	x	
	VxWorks RTOS		x

### Interface Changes Related to Product Restructuring

You will see interface changes as part of restructuring the Coder products.

- In the Simulink Configuration Parameters dialog box, changes to code generation related elements
- In Simulink menus, changes to code generation related elements
- In Simulink blocks, including block parameters and dialog boxes, and block libraries, changes to code generation related elements
- In error messages, tool tips, demos, and product documentation, references to Real-Time Workshop Embedded Coder, Real-Time Workshop, and Stateflow Coder and related terms are replaced with references to the latest software

### Simulink Graphical User Interface Changes

Where...	Previously...	Now...
Configuration Parameters dialog box	<b>Real-Time Workshop</b> pane	<b>Code Generation</b> pane
Model diagram window	<b>Tools &gt; Real-Time Workshop</b>	<b>Tools &gt; Code Generation</b>
Subsystem context menu	<b>Real-Time Workshop</b>	<b>Code Generation</b>
Subsystem Parameter dialog box	Following parameters on main pane: <ul style="list-style-type: none"> <li>• <b>Real-Time Workshop system code</b></li> <li>• <b>Real-Time Workshop function name options</b></li> <li>• <b>Real-Time Workshop function name</b></li> <li>• <b>Real-Time Workshop file name options</b></li> </ul>	On new <b>Code Generation</b> pane and renamed: <ul style="list-style-type: none"> <li>• <b>Function packaging</b></li> <li>• <b>Function name options</b></li> <li>• <b>Function name</b></li> <li>• <b>File name options</b></li> <li>• <b>File name (no extension)</b></li> </ul>

Where...	Previously...	Now...
	<ul style="list-style-type: none"> <li>• <b>Real-Time Workshop file name (no extension)</b></li> </ul>	

## Compatibility Considerations

In the Help browser **Contents** pane, Embedded Coder is now listed with the products for MATLAB, because Embedded Coder now supports both MATLAB Coder and Simulink Coder workflows.

## Data Management Enhancements and Changes

- “Memory Section Enhancements” on page 14-6
- “No Longer Able to Set RTWInfo or CustomAttributes Property of Simulink Data Objects” on page 14-6
- “Parts of Data Class Infrastructure Not Available” on page 14-7
- “No Longer Generating Pragma for Data Defined with Built-In Storage Class ExportedGlobal, ImportedExtern, or ImportedExternPointer” on page 14-8
- “Simulink.CustomParameter and Simulink.CustomSignal Data Classes To Be Deprecated in a Future Release” on page 14-9

### Memory Section Enhancements

- Pragma are now added to data and function declarations (prior to R2011a they were added to definitions only); at compile time, this makes the compiler aware of memory locations for functions and data, potentially optimizing generated code
- New function category is available for shared utilities on the **Code Generation > Memory Sections** pane: Shared utility
- Referenced models can have a memory section that is different from that of the top model for the `InitTerm` and `Execute` function categories

### No Longer Able to Set RTWInfo or CustomAttributes Property of Simulink Data Objects

You can not set the `RTWInfo` or `CustomAttributes` property of a Simulink data object from the MATLAB Command Window or a MATLAB script. Attempts to set these properties generate an error.



Although you cannot set `RTWInfo` or `CustomAttributes`, you can still set subproperties of `RTWInfo` and `CustomAttributes`.

## Compatibility Considerations

Operations from the MATLAB Command Window or a MATLAB script, which set the data object property `RTWInfo` or `CustomAttributes`, generate an error.

For example, a MATLAB script might set these properties by copying a data object as shown below:

```
a = Simulink.Parameter;
b = Simulink.Parameter;
b.RTWInfo = a.RTWInfo;
b.RTWInfo.CustomAttributes = a.RTWInfo.CustomAttributes;
.
.
.
```

To copy a data object, use the object's `deepCopy` method.

```
a = Simulink.Parameter;
b = a.deepCopy;
.
.
.
```

### Parts of Data Class Infrastructure Not Available

Simulink has been generating warnings for usage of the following data class infrastructure features for several releases. As of R2011a, the features are not supported.

- Custom storage classes not captured in the custom storage class registration file (`csc_registration`) – *warning displayed since R14SP2*
- Built-in custom data class attributes `BitFieldName` and `FileName+IncludeDelimiter` – *warning displayed since R2008b*

Instead of...	Use...
<code>BitFieldName</code>	<code>StructName</code>
<code>FileName+IncludeDelimiter</code>	<code>HeaderFile</code>

- Initial value of MPT data objects inside `mpt.CustomRTWInfoSignal` – *warning displayed since R2006a*

## Compatibility Considerations

- When you use a removed feature, Simulink now generates an error.
- When loading a MAT-file that uses an unsupported feature, the load operation suppresses the generated error such that it is not visible. In addition, MATLAB silently deletes data that had been associated with the unsupported feature. To prevent loss of data when loading a MAT-file, load and resave the file with R2010b or earlier.

### No Longer Generating Pragma for Data Defined with Built-In Storage Class `ExportedGlobal`, `ImportedExtern`, or `ImportedExternPointer`

The code generator no longer generates a `pragma` around definitions or declarations for data that has the following built-in storage classes:

- `ExportedGlobal`
- `ImportedExtern`
- `ImportedExternPointer`

Prior to R2011a, based on model configuration parameters for specifying memory sections and the built-in storage class defined for data, the code generator would do the following:

For Built-In Storage Class...	Generate pragma Around...
<code>ExportedGlobal</code>	Data definition and declaration
<code>ImportedExtern</code>	Data declaration
<code>ImportedExternPointer</code>	Data declaration

The code generator now treats data with these built-in storage classes like custom storage classes with no memory section specified.

## Compatibility Considerations

To work around this change, select a custom storage class that uses the memory section of interest for the data.

## **Simulink.CustomParameter and Simulink.CustomSignal Data Classes To Be Deprecated in a Future Release**

In a future release, data classes `Simulink.CustomParameter` and `Simulink.CustomSignal` will no longer be supported because they are equivalent to `Simulink.Parameter` and `Simulink.Signal`.

## **Compatibility Considerations**

If you use the data class `Simulink.CustomParameter` or `Simulink.CustomSignal`, Simulink posts a warning that identifies the class and describes one or more techniques for eliminating it. You can ignore these warnings in R2011a, but consider making the described changes now because the classes will be removed in a future release.

## **AUTOSAR Enhancements**

The following enhancements are available in R2011a.

### **Calibration Parameters**

Previously, the software supported only calibration parameters that were defined by a calibration component. These parameters could be accessed by all AUTOSAR Software Components. The AUTOSAR standard also specifies an internal calibration parameter that is defined and accessed by only one AUTOSAR Software Component. The software now supports:

- AUTOSAR internal calibration parameters, including the import and export of initial values of these parameters.
- A bus object data type (AUTOSAR record type) to import and export both kinds of calibration parameters.

For more information, see [Calibration Parameters and Configure Calibration Parameters](#) in the Embedded Coder documentation.

### **Multiple Runnables from Virtual Subsystems**

Previously, if a wrapper subsystem had virtual subsystems containing function-call subsystems, you could not export the function-call subsystems as AUTOSAR runnables from the wrapper subsystem level. Now, within a wrapper subsystem, you can group

function-call subsystems into virtual subsystems and generate runnables for these function-call subsystems. See *Configure Multiple Runnables and Export AUTOSAR Software Component* in the *Embedded Coder* documentation.

## Support for Code Descriptor Elements

The AUTOSAR standard specifies that the XML description of an AUTOSAR Software Component implementation must contain code descriptor elements to describe generated source files and include header files. This feature allows AUTOSAR authoring tools that import software components to automate the building process for source code.

Previously, the software did not generate the software component implementation file (*modelName\_implementation.arxml*) with these code descriptor elements. Now, when you build a Simulink model for an AUTOSAR target, the software generates a `CODE-DESCRIPTORS` element within the `SWC_IMPLEMENTATION` element. The `CODE-DESCRIPTORS` element contains `XFILE` elements that provide descriptions of the generated code.

For example, if you build the model `rtwdemo_autosar_counter`, the generated file `rtwdemo_autosar_counter_implementation.arxml` has the following `SWC_IMPLEMENTATION` element:

```

....
<SWC-IMPLEMENTATION>
  <SHORT-NAME>rtwdemo_autosar_counter</SHORT-NAME>
  <CODE-DESCRIPTORS>
    <CODE>
      <SHORT-NAME>Code</SHORT-NAME>
      <TYPE>SRC</TYPE>
      <XFILES>
        <XFILE>
          <SHORT-NAME>rtwdemo_autosar_counter_c</SHORT-NAME>
          <CATEGORY>GeneratedFile</CATEGORY>
          <URL>rtwdemo_autosar_counter_autosar_rtw\rtwdemo_autosar_counter.c</URL>
          <TOOL>Embedded Coder</TOOL>
          <TOOL-VERSION>5.6</TOOL-VERSION>
        </XFILE>
        <XFILE>
          <SHORT-NAME>rtwdemo_autosar_counter_h</SHORT-NAME>
          <CATEGORY>GeneratedFile</CATEGORY>
          <URL>rtwdemo_autosar_counter_autosar_rtw\rtwdemo_autosar_counter.h</URL>
          <TOOL>Embedded Coder</TOOL>
          <TOOL-VERSION>5.6</TOOL-VERSION>
        </XFILE>
      </XFILES>
    </CODE>
  </CODE-DESCRIPTORS>
  <CODE-GENERATOR>Embedded Coder 5.6 (R2011a) 26-Aug-2010</CODE-GENERATOR>

```

```
<PROGRAMMING - LANGUAGE>C</PROGRAMMING - LANGUAGE>  
</SWC - IMPLEMENTATION>  
.....
```

## SIL and PIL Enhancements

### Code Execution Profiling

You can collect execution time measurements in a specified base workspace variable during a software-in-the-loop (SIL) or processor-in-the-loop (PIL) simulation. At the end of the simulation, you can view or analyze the measurements within the MATLAB environment. This feature allows you to collect an execution time profile for each task within your generated code.

The software supports code execution profiling for all types of SIL or PIL simulations except the SIL block.

For more information, see *Code Execution Profiling in the Embedded Coder documentation*.

### PIL Block Parameter Tuning

R2011a supports parameter tuning for the PIL block, which allows you to change tunable workspace parameters between or during simulations without regenerating code. This feature also includes support for tunable structure parameters. For more information, see *I/O Support and Tunable Parameters and SIL/PIL*.

### Top-Model SIL/PIL and PIL Block Parameter Initialization

R2011a supports automatic definition and initialization of parameters with imported storage classes. For more information, see *I/O Support and Imported Data Definitions*.

### Model Block Parameter Tuning and Model Initialization

Previously, the software did not support the following features for Model block SIL/PIL:

- Simplified initialization mode
- Tunable structure parameters

R2011a now supports these features. For more information, see *Configuration Parameters Support, I/O Support, and Tunable Parameters and SIL/PIL*.

## Code Generation Enhancements

### Improved Code for Data Store Memory In-place Assignment

Previously, the generated code for a Data Store Memory block used data copies to perform data store assignments. The generated code now eliminates the data copies and performs an in-place assignment. This improvement generates less code, uses less memory, and provides faster execution.

### Improvements to Target Function Library Replacements

Enhancements to Target Function Library Replacements (TFL) include:

- If multiple TFL replacements occur within a function, temporary variables are now reused instead of creating extra temporary variables. This enhancement reduces the stack size during TFL replacement.
- During TFL replacement, if unnecessary temporary variables are introduced when block output is not the returned value of the function but one of the input arguments, code generation now removes the temporary variable. This enhancement improves execution speed and requires less memory.

For more information, see [Introduction to Code Replacement Libraries](#).

### Improved Loop Fusion

Code generation now includes the following:

- An improved loop fusion algorithm that reduces data copies. This enhancement decreases stack size, ROM consumption, and code generation time.
- Selectively fuses loops when the loop count is larger than the Loop unrolling threshold. In these cases, loop unrolling allows the code generator to perform more optimizations. In addition, the code generator groups the statements together to assign values to the elements of a signal or parameter array, which improves data access and code readability.

### Improved Array Indexing

The generated code is optimized for more efficient array indexing. When a complex instruction is used repeatedly in an array index, the instruction is replaced with a temporary variable to perform the calculation more efficiently. This enhancement improves execution speed and reduces code size.

### **Improvement on Matrix Parameter Pooling**

For matrix parameters with the same flattened value, the generated code now pools the matrix parameters even when they have different shapes. This enhancement reduces ROM consumption.

### **Readability Improvements Involving Data References**

For references to the root inport and outport, as well as DWork, unnecessary parentheses are removed from the generated code. This enhancement produces more readable code.

## **Code Generation Verification (CGV) API Updates**

### **Support for Adding Multiple Callback Functions**

In R2011a, the `cgv.CGV` class includes new methods to add callback functions. These methods replace the `cgv.CGV.addCallback` method which added only a pre-execution callback function. Now, the new methods allow CGV to invoke callback functions at several stages of the `cgv.CGV.run` execution. The new methods are:

- `cgv.CGV.addHeaderReportFcn` adds a callback function invoked before executing input data in the `cgv.CGV` object.
- `cgv.CGV.addPreExecReportFcn` adds a callback function invoked before executing each input data file in the `cgv.CGV` object.
- `cgv.CGV.addPreExecFcn` adds a callback function invoked before executing each input data file in the `cgv.CGV` object.
- `cgv.CGV.addPostExecReportFcn` adds a callback function invoked after executing each input data file in the `cgv.CGV` object.
- `cgv.CGV.addPostExecFcn` adds a callback function invoked after executing each input data file in the `cgv.CGV` object.
- `cgv.CGV.addTrailerReportFcn` adds a callback function invoked after executing input data in the `cgv.CGV` object.

### **New Functionality Added to the `cgv.CGV` Class**

The `cgv.CGV` class now includes the following methods:

- `cgv.CGV.activateConfigSet` activates the configuration set of a model.
- `cgv.CGV.addBaseline` adds a file of baseline data for comparison.
- `cgv.CGV.copySetup` creates a copy of a `cgv.CGV` object.

- `cgv.CGV.setMode` specifies the mode of execution (`sim`, `sil`, or `pil`).
- `cgv.CGV.copySetup` returns the status of the execution of the `cgv.CGV` object.

The `cgv.CGV` class now includes the following properties:

- Name
- Description

## Compatibility Considerations

Previously, the `cgv.CGV` class included parameters that you set to perform automatic configuration checks of your model. In R2011a, `cgv.CGV` class does not perform automatic configuration checks. Instead, you can use the `cgv.Config` class to perform a manual configuration check of your model. Before calling `cgv.CGV.run`, perform a manual configuration check of your model. Otherwise, an error might occur later in the process. For more information, see Programmatic Code Generation Verification.

Changes to the `cgv.CGV` class parameters are listed in the following table.

Parameter	What Happens When You Use Parameter?	Use This Parameter Instead	Compatibility Considerations
<code>LogMode</code> removed from <code>cgv.CGV</code>	Errors	<code>LogMode</code> parameter in <code>cgv.Config</code>	To check your model before running CGV, pass the <code>LogMode</code> parameter to the constructor for <code>cgv.Config</code> . Then call the <code>cgv.Config.configModel</code> method to adjust the model configuration.
<code>Processor</code> removed from <code>cgv.CGV</code>	Errors	<code>Processor</code> parameter in <code>cgv.Config</code>	To check your model before running CGV, pass the <code>Processor</code> parameter to the constructor for <code>cgv.Config</code> . Then call the <code>cgv.Config.configModel</code>



Parameter	What Happens When You Use Parameter?	Use This Parameter Instead	Compatibility Considerations
			method to adjust the model configuration.
<code>SaveModel</code> removed from <code>cgv.CGV</code>	Errors	<code>SaveModel</code> parameter in <code>cgv.Config</code>	To check your model before running CGV, pass the <code>SaveModel</code> parameter to the constructor for <code>cgv.Config</code> . Then call the <code>cgv.Config.configModel</code> method to adjust the model configuration.
<code>ConfigModel</code> removed from <code>cgv.CGV</code>	Warns if set to off Errors if set to on	<code>cgv.Config.configModel</code> method	To check your model before running CGV, replace the <code>cgv.CGVConfigModel</code> parameter with a call to the <code>cgv.Config.configModel</code> method
<code>CheckInterface</code> parameter from <code>cgv.CGV</code>	Warns if set to off Errors if set to on	<code>CheckOutputs</code> parameter in <code>cgv.Config</code>	To check your model before running CGV, pass the <code>CheckOutputs</code> parameter to the constructor for <code>cgv.Config</code> . Then call the <code>cgv.Config.configModel</code> method to adjust the model configuration.

Parameter	What Happens When You Use Parameter?	Use This Parameter Instead	Compatibility Considerations
tasking and custom values removed from the <code>Connectivity</code> parameter of <code>cgv.CGV</code>	Errors	<code>pil</code> , a new value for the <code>cgv.CGV Connectivity</code> parameter	Replace calls to the <code>cgv.CGV</code> constructor using the parameter-value arguments, ( <code>'Connectivity'</code> , <code>'tasking'</code> ) or ( <code>'Connectivity'</code> , <code>'custom'</code> ), with ( <code>'Connectivity'</code> , <code>'pil'</code> ).

Changes to the `cgv.Config` class parameters are listed in the following table:

Parameter	What Happens When You Use Parameter?	Compatibility Considerations
<code>CheckOutports</code> parameter added to <code>cgv.Config</code>	Defaults to <code>on</code> . Compiles the model. Then checks that the model outputport configuration is compatible with the <code>cgv.CGV</code> object.	If your script fixes errors reported by <code>cgv.Config</code> , you can set <code>CheckOutports</code> to <code>off</code> .
<code>LogMode</code> parameter from <code>cgv.Config</code>	Change in behavior	If you do not give a value for <code>LogMode</code> , logging changes are not made to the configuration parameters.

## MISRA-C Code Generation Objective

The Code Generation Advisor now includes a new objective for MISRA-C:2004 guidelines. To set the new objective, open the Configuration Parameters dialog box and select the **Code Generation** pane. In the Code Generation Advisor section, click the **Set objectives** button to open the Code Generation Advisor dialog box. In the **Available objectives** list, select `MISRA-C:2004 guidelines` and click the select button (arrow pointing right) to move the objective to the **Selected objectives** list. For more information on setting objectives, see Application Objectives.

## New Model Advisor Check for Code Efficiency of Lookup Table Blocks

The Simulink Model Advisor includes the following new check for code efficiency of lookup table blocks: Identify lookup table blocks that generate expensive out-of-range checking code. By default, the following blocks generate code that checks for out-of-range breakpoint inputs:

- 1-D Lookup Table
- 2-D Lookup Table
- n-D Lookup Table
- Prelookup

Similarly, the Interpolation Using Prelookup block generates code that checks for out-of-range index inputs. Running this Model Advisor check helps you identify lookup table blocks that generate out-of-range checking code for breakpoint or index inputs.

For more information about the Model Advisor, see Consulting the Model Advisor in the Simulink documentation.

## Enhanced Code Generation Optimization

The **Optimize using specified minimum and maximum values** code generation option now takes into account the minimum and maximum values specified for:

- A `Simulink.Parameter` object provided that it is used on its own. It does not use these minimum and maximum values if the object is part of an expression. For example, if a Gain block has a gain parameter specified as `K1`, where `K1` is defined as a `Simulink.Parameter` object in the base workspace, the optimization takes the minimum and maximum values of `K1` into account. However, if the Gain block has a gain parameter of `K1+5` or `K1+K2+K3`, where `K2` and `K3` are also `Simulink.Parameter` objects, the optimization does not use the minimum and maximum values of `K1`, `K2` or `K3`.
- Design ranges specified on block outputs in a conditionally-executed subsystem, except for the block outputs that are directly connected to an Outputport block.

For more information, see Optimize Generated Code Using Specified Minimum and Maximum Values.

## Target Function Library Replacement Based on Computation Method for Reciprocal Sqrt, Sine, and Cosine

Target function libraries (TFLs) now support the ability to control replacement of certain math functions using their computation method as a distinguishing attribute. For example,

- The `rSqrt` block can be configured to use either of two computation methods, `Newton-Raphson` or `Exact`.
- The Trigonometric Function block, with **Function** set to `sin` or `cos`, can be configured to use either of two approximation methods, `CORDIC` or `None`.

You can configure TFL table entries to replace these functions for one or all of the available computation methods. For example, you could replace only `Newton-Raphson` instances of the `rSqrt` function.

For more information, see [Replace Math Functions Based on Computation Method](#) in the Embedded Coder documentation.

## Target Function Library Support for `abs`, `min`, `max`, and `sign` functions

Embedded Coder software now supports target function library customization control for fixed-point `abs`, `min`, `max`, and `sign` functions.

For more information, see [Register Code Replacement Libraries](#).

## C++ Encapsulation Allowed for Referenced Models in For Each Subsystems

In previous releases, due to a code generation limitation, code could not be generated for a For Each Subsystem block under the following conditions:

- The For Each Subsystem block directly or indirectly contains a Model block.
- The Model block references a model for which C++ encapsulation is selected.

R2011a removes this limitation. You can now generate code for a For Each Subsystem in which a referenced model uses C++ encapsulation.

## Improved Code Generation for Portable Word Sizes

In the software-in-the-loop (SIL) simulation work flow, the model option **Enable portable word sizes** allows you to take code intended for a specific target platform and compile and run the same code on a MATLAB host platform that uses different processor word sizes. R2011a enhances the code generated for portable word sizes by inserting explicit casts to help protect against integral promotion differences and other behavior differences between host and target. This potentially can reduce the incidence of numerical differences due to host/target behavior differences. For more information, see Configure Hardware Implementation Settings for SIL and Portable Word Sizes Limitations in the Embedded Coder documentation.

## Improved Comments in the Generated Code

R2011a provides improvements to comment generation for better readability and understanding of the generated code. Specifically, comments are located closer to the referring code and reflect the intent of the code. An end comment is now included at the end of a control flow block of code. For information on customizing comments in the generated code, see Configure Code Comments in Embedded System Code.

## Replacement Data Types and Simulation Mode for Referenced Models

To replace built-in data type names with user-defined data type names in the generated code for a referenced model, you must set the **Simulation mode** parameter for the Model block to one of the following:

- Normal
- `Software-in-the-loop (SIL)`
- `Processor-in-the-loop (PIL)`

For more information, see Data Types and Referenced Model Simulation Modes in the Simulink documentation.

## Changes for Embedded IDEs and Embedded Targets

- “Feature Support for Embedded IDEs and Embedded Targets” on page 14-20
- “Execution Profiling during PIL Simulation” on page 14-21

- “Location of Blocks for Embedded Targets” on page 14-21
- “Location of Demos for Embedded IDEs and Embedded Targets” on page 14-22
- “Multicore Deployment with Rate-Based Multithreading” on page 14-23
- “Windows-Based Code Generation and Remote Build On Linux Target (BeagleBoard)” on page 14-24
- “Changes to Frame-Based Processing” on page 14-24
- “New Support for Analog Devices Blackfin BF50x and BF51x Processors” on page 14-25
- “Generate Optimized Fixed-Point Code for ARM Cortex-M3, Cortex-A8, and Cortex-A9 Processors” on page 14-26
- “Support for Versions 5.0.6 and 5.1.6 of Green Hills MULTI” on page 14-26
- “Support for Texas Instruments Delfino C2834x Processors” on page 14-26
- “Ending Support for Altium TASKING in a Future Release” on page 14-27
- “Ending Support for Freescale MPC5xx in a Future Release” on page 14-27
- “Ending Support for Infineon C166 in a Future Release” on page 14-27
- “Removed Methods and Arguments” on page 14-27

### **Feature Support for Embedded IDEs and Embedded Targets**

The Embedded Coder software provides the following features as implemented in the former Target Support Package and former Embedded IDE Link products:

- Automation Interface
- Processor-in-the-Loop (PIL) Simulation
- Execution Profiling
- Execution Profiling during PIL Simulation
- Stack Profiler
- External Mode
- Schedulers and Timing
- Makefile Generation (XMakefile)
- Target Function Library (TFL) Optimization
- Multicore Deployment for Rate Based Multithreading

---

**Note:** You can only use these features in the 32-bit version of your MathWorks products. To use these features on 64-bit hardware, install and run the 32-bit versions of your MathWorks products.

---

## Execution Profiling during PIL Simulation

During Processor-in-the-loop (PIL) simulation, you can profile synchronous tasks in code running on the target. For more information, see [Execution Profiling during PIL Simulation](#)

## Location of Blocks for Embedded Targets

Blocks from the former Target Support Package product and Embedded IDE Link product now reside under Embedded Coder in the Embedded Targets block library, as shown.

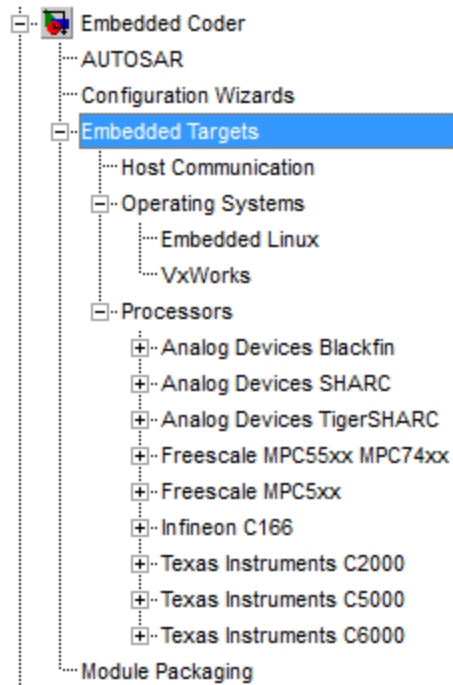

Embedded Targets includes the following types of blocks:

- Host Communication
- Operating Systems
  - Embedded Linux
  - VxWorks
- Processors
  - Analog Devices Blackfin
  - Analog Devices SHARC
  - Analog Devices TigerSHARC
  - Freescale MPC55xx MPC74xx
  - Freescale MPC5xx
  - Infineon C166
  - Texas Instruments C2000
  - Texas Instruments C5000
  - Texas Instruments C6000

### **Location of Demos for Embedded IDEs and Embedded Targets**

Demos from the former Target Support Package product and Embedded IDE Link product now reside under Simulink Coder product help. Click the expandable links, as shown.



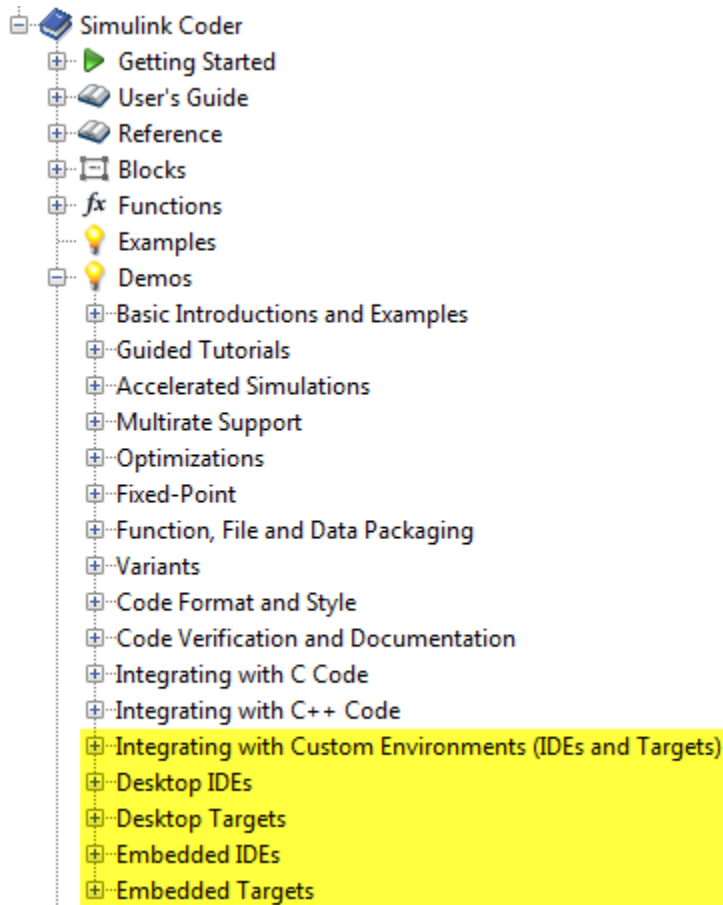

## Multicore Deployment with Rate-Based Multithreading

You can deploy rate-based multithreading applications to multicore processors running Embedded Linux and

VxWorks. This feature improves performance by taking advantage of multicore hardware resources.

Also see the [Running Target Applications on Multicore Processors](#) user's guide topic.

## Windows-Based Code Generation and Remote Build On Linux Target (BeagleBoard)

You can generate a makefile project on a Windows host machine, transfer the makefile project to an remote target running Linux, such as a BeagleBoard, and then build the executable on the remote target.

## Changes to Frame-Based Processing

Signal processing applications often process sequential samples of data at once as a group, rather than one sample at a time. MathWorks documentation refers to the former as *frame-based processing* and the latter as *sample-based processing*. A *frame* is a collection of samples of data, sequential in time. To perform frame-based processing in MathWorks products, you must have a DSP System Toolbox license.

Historically, Simulink-family products that can perform frame-based processing propagate frame-based signals throughout a model. The frame status is an attribute of the signals in a model, just as data type and dimensions are attributes of a signal. The Simulink engine propagates the frame attribute of a signal with a frame bit, which can either be on or off. When the frame bit is on, Simulink interprets the signal as frame-based, and displays it as a double line, rather than as a single line.

Beginning in R2010b, MathWorks started to change the handling of frame-based processing significantly. In the future, signal attributes will not include frame status. Instead, individual blocks will control whether they treat data inputs as frames or as samples.

To transition to this new paradigm, blocks that can perform sample- and frame-based processing contain a new **Input processing** parameter that specifies the processing behavior. You can set **Input processing** to **Columns as channels (frame based)** or **Elements as channels (sample based)**. The third option, **Inherited (this choice will be removed - see release notes)**, is a temporary selection. This third option helps you migrate your existing models from the old paradigm to the new paradigm.

In R2011a, the following Embedded Coder blocks received a new **Input processing** parameter:

- C62X Real Forward Lattice All-Pole IIR
- C62X Complex FIR
- C62X General Real FIR
- C62X Real IIR

- C64X Real Forward Lattice All-Pole IIR

## Compatibility Considerations

When you load an existing model in R2011a, blocks with the new **Input processing** parameter shows a setting of **Inherited** (this choice will be removed - see release notes). This setting enables your existing models to work as expected until you upgrade them. Upgrade your models as soon as possible.

To upgrade your existing models, use the `slupdate` function. This function detects blocks that have **Input processing** set to **Inherited** (this choice will be removed - see release notes). The function asks you whether to upgrade each block. If you select yes, the function detects the status of the frame bit on the input port of the block. If the frame bit is 1 (frames), the function sets the **Input processing** parameter to **Columns as channels** (frame based). If the bit is 0 (samples), the function sets the parameter to **Elements as channels** (sample based).

A future release will remove the **Inherited** (this choice will be removed - see release notes) option. At that time, if you have not updated the model, the software automatically sets the **Input processing** parameter. The software uses the library default setting of the block to select either **Columns as channels** (frame based) or **Elements as channels** (sample based). If the library default setting does not match the parameter setting in your model, your model will produce unexpected results. Additionally, after the removal of the frame bit, you will no longer be able to upgrade your models using the `slupdate` function. Therefore, upgrade your existing models using `slupdate` as soon as possible.

## New Support for Analog Devices Blackfin BF50x and BF51x Processors

You can now generate code for the following embedded processors when you use Embedded Coder software:

- BF504
- BF504F
- BF506F
- BF512
- BF514
- BF516
- BF518

## **Generate Optimized Fixed-Point Code for ARM Cortex-M3, Cortex-A8, and Cortex-A9 Processors**

You can use new Target Function Libraries (TFLs) to generate efficient fixed-point code for the ARM Cortex-M3, Cortex-A8, and Cortex-A9 processors. These TFLs include GCC compiler extensions and intrinsic functions that optimize the code Embedded Coder generates for these processors.

### **Support for Versions 5.0.6 and 5.1.6 of Green Hills MULTI**

Support for Green Hills MULTI software now includes versions 5.0.6 and 5.1.6.

### **Support for Texas Instruments Delfino C2834x Processors**

You can now generate code for the following embedded processors when you use Embedded Coder software with Texas Instruments Code Composer Studio software:

- C28341
- C28342
- C28343
- C28344
- C28345
- C28346

The new C2834x (c2834xlib) block library contains the following blocks:

- C2000 CAN Calibration Protocol
- C280x/C2802x/C2803x/C28x3x/c2834x GPIO Digital Input
- C280x/C2802x/C2803x/C28x3x/c2834x GPIO Digital Output
- C280x/C2802x/C2803x/C28x3x/C2834x I2C Receive
- C280x/C2802x/C2803x/C28x3x/C2834x I2C Transmit
- C280x/C2802x/C2803x/C28x3x/c2834x SCI Receive
- C280x/C2802x/C2803x/C28x3x/c2834x SCI Transmit
- C280x/C2802x/C2803x/C28x3x/c2834x SPI Receive
- C280x/C2802x/C2803x/C28x3x/c2834x SPI Transmit
- C280x/C2802x/C2803x/C28x3x/c2834x Software Interrupt Trigger
- C28x Watchdog

- C280x/C2803x/C28x3x/c2834x eCAN Receive
- C280x/C2803x/C28x3x/c2834x eCAN Transmit
- C280x/C2802x/C2803x/C28x3x/c2834x eCAP
- C280x/C2802x/C2803x/C28x3x/c2834x ePWM
- C280x/C2803x/C28x3x/c2834x eQEP

### **Ending Support for Altium TASKING in a Future Release**

Support for the Altium TASKING IDE will end in a future release of the Embedded Coder product.

### **Ending Support for Freescale MPC5xx in a Future Release**

Support for the Freescale MPC5xx processor family will end in a future release of the Embedded Coder product.

### **Ending Support for Infineon C166 in a Future Release**

Support for the Infineon C166 processor family will end in a future release of the Embedded Coder product.

### **Removed Methods and Arguments**

Deprecated the `type` property for the Code Composer Studio IDE object. For example, entering the following text generates an error message:

```
infolist = IDE_Obj.list(type)
```

### **Changes to ver Function Product Arguments**

The following changes have been made to `ver` function arguments related to embedded code generation products:

- The new argument `'embeddedcoder'` returns information about the installed version of the Embedded Coder product.
- The argument `'ecoder'`, which previously returned information about the installed version of the Real-Time Workshop Embedded Coder product, no longer works. The software displays a “not found” warning.

For more information about using the function, see the `ver` documentation.

## Compatibility Considerations

If a script calls the `ver` function with the `'ecoder'` argument, update the script appropriately. For example, you can update the `ver` call to use the `'embeddedcoder'` argument.

## New and Enhanced Demos

The following demos have been added in R2011a:

Demo...	Shows How You Can...
<code>coderdemo_tfl</code>	Use target function libraries (TFLs) to replace operators and functions in code generated by MATLAB Coder.
<code>rtwdemo_code_coverage_script</code>	Generate model coverage and code coverage reports, and use these reports to compare model coverage and code coverage results for parts of a model.
<code>rtwdemo_pmsmfoc_script</code>	Perform system-level simulation and algorithmic code generation using Field-Oriented Control for a Permanent Magnet Synchronous Machine.

The following demos have been enhanced in R2011a:

Demo...	Now...
<code>vipstabilize_fixpt_beagleboard</code>	Uses the new Video Capture block to simulate or capture a video input signal in the Video Stabilization demo.

## Check bug reports for issues and fixes

Software is inherently complex and is not free of errors. The output of a code generator might contain bugs, some of which are not detected by a compiler. MathWorks reports critical known bugs brought to its attention on its Bug Report system at [www.mathworks.com/support/bugreports/](http://www.mathworks.com/support/bugreports/). Use the Saved Searches and Watched Bugs tool with the search phrase "Incorrect Code Generation" to obtain a report of known bugs that produce code that might compile and execute, but still produce wrong answers.

The bug reports are an integral part of the documentation for each release. Examine periodically all bug reports for a release, as such reports may identify inconsistencies between the actual behavior of a release you are using and the behavior described in this documentation.

In addition to reviewing bug reports, you should implement a verification and validation strategy to identify potential bugs in your design, code, and tools.

